

ADC SERIES

Analog to Digital Converters

The ADC Series Signal Converter connects up to eight analog sensors, or up to eight separately powered analog output sensors, or up to four of each. This will produce a digital signal representing 0–100% of each sensor output. It is the perfect solution for photovoltaic power production system monitoring. The ADC converter allows for individually-ranged devices to interface with the industry-standard **Modbus RTU** serial protocol. The device can accept analog signals from current, voltage or temperature sensors, allowing the installer great versatility and higher accuracy. It was designed and built to meet NK Technologies' trusted standards of reliability and ease of use.

Signal Converter Applications

Photovoltaic Power Production

- Measure current output accurately using a sensor sized appropriately.
- Measure current from a panel and after the combiner with the same device.
- Measure voltage output, temperature, or any parameter sensor 4–20 mA, 0–5 VDC or 0–10 VDC output.

Machine Control

- Combine several analog signals into a single **Modbus** address to enable web viewing of data.

SCADA System

- Report and record current, voltage, power, pressure, frequency and flow by using existing sensors but adding network communication easily.

Analog Sensor to Digital Network Conversion

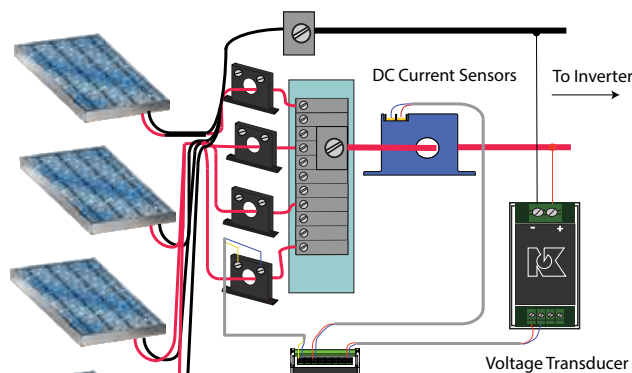

Signal Converter Features

Eight Points of Data

- Convert up to eight analog, sensor outputs using a single network address.
- Sensor loop power is supplied by the converter: No DC power supply is required.
- Models for 8 loop-powered (2-wire) and 8 externally powered (4-wire) or 4 of each type.

Fast and Easy Installation

- DIN rail mount converter* with finger-safe terminals clearly marked for field installation speed.

Application Versatility

- Convert any standard sensor output to **Modbus RTU** digital network format.

Choice of Power Supplies

- ADC converter can be factory set for 120 VAC, 240 VAC or 24 VDC power supplies.

Communication Baud Rate Choices

- Field-selectable 9600 or 19200 baud rate speeds.

*For information on the DIN rail accessories kit, see page 140.

Use any 4–20 mA, 0–5 VDC or 0–10 VDC output sensor as an input to the NK Technologies' ADC analog-to-**Modbus** converter: Current, voltage, temperature, or any parameter that the application calls for. With the digital **Modbus** output scaled for zero to 100 percent the signal will represent whatever you may need to measure.

- For additional Application Examples, go to www.nktechnologies.com/applications

Signal Converter Dimensions

Side View

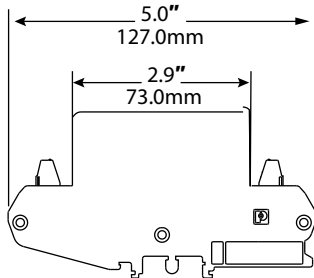

End View

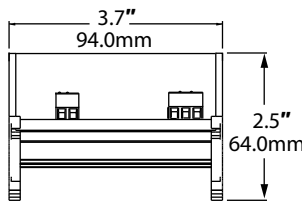

Signal Converter Connections

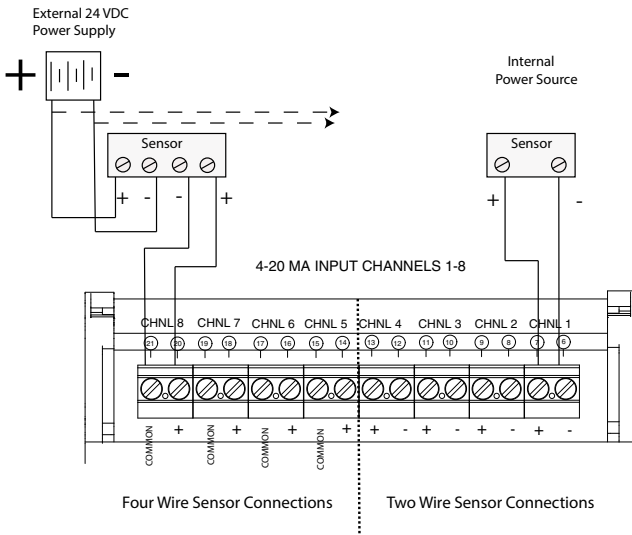

Wiring Notes for Installation:

1. Connect sensors to input channel terminals 6–21.
2. Set **Modbus** network address 1–247.
3. Connect 120 VAC power (240 VAC optional).

Signal Converter Specifications



Power Supply	<ul style="list-style-type: none"> • 120 VAC (108–132 V) • 240 VAC (216–264 V) • 24 VDC (22–26 V)
Power Consumption	<ul style="list-style-type: none"> • 120 VAC: <50 mA • 240 VAC: <25 mA • 24 VDC: <200 mA
Output	Modbus RTU Slave 8 Channels (RS485)
Output Protocol	1 start bit, 8 data bits (LSB first), 1 bit for even parity, 1 stop bit
Output Functions	Function 04, "Read Input Registers"
Output Range	0–120% (4 mA = 0, 20 mA = 100%)
Input Range	<ul style="list-style-type: none"> • 4–20 mA (power from converter or external) • 0–5 VDC (externally powered) • 0–10 VDC (externally powered)
Accuracy	1.0% FS
Indication	Green Power On LED, yellow Busy LED, red Fault LED
Addressing	8 wide binary switch (1 to 247)
Environmental	-4 to 122°F (-20 to 50°C) 0–95% RH, non-condensing
Listings	UL/cUL

Signal Converter Ordering Information

Sample Model Number: ADC1-420-120-MOD-DIN
Eight-channel 4–20 mA input converter, 120 VAC powered.

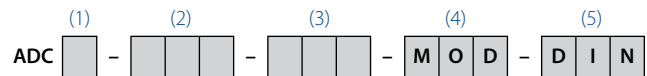

(1) Input channels

1	Eight 4–20 mA loop-powered input channels
2	Four loop-powered, four external powered (4-wire)
3	Eight external-powered inputs

(2) Sensor Input Type

420	4–20 mA inputs
005	0–5 VDC
010	0–10 VDC as inputs available

(4) Output Type

MOD	Modbus RTU
-----	------------

(5) Case Style

DIN	DIN rail mounting
-----	-------------------

(3) Power Supply

120	120 VAC
240	240 VAC
24D	24 VDC

Signal Converters

OEMs Test & Evaluation Units for OEMs
Free program expedites evaluation process. See page 3 for details.

