

AG SERIES

Ground Fault (Earth Leakage) Relay

AG Series Ground Fault Detectors help protect people, products, and processes from damage by ground fault conditions by monitoring all current-carrying conductors in grounded single- and three-phase delta or wye systems.



Ground Fault Protection

Ground Fault Protection Applications

Personnel Protection (typically 5 mA)

- Detects sensitive ground fault conditions, which may be injurious to personnel and processes.
- Functions as sensor and alarm trigger when part of an overall ground fault protection system.

Equipment Protection (typically 10 mA or 30 mA)

- For applications where personal protection is not the primary concern, higher setpoint capability helps eliminate nuisance tripping while still providing adequate ground fault detection to protect machine electronics.

Regulatory

- Meets requirements as stipulated by governmental and industrial regulatory groups for ground fault sensing.

Ground Fault Protection Features

Broad Range of Options to Match Application Needs

- N.O./N.C. solid-state switch or mechanical relay outputs.
- Normally energized or normally de-energized contacts.
- Noise Immunity option for use in EMI/RFI sensitive environments.

Setpoint Options Maximize Ease-of-Use

- Field-selectable 5 mA, 10 mA or 30 mA setpoints on the AG3 “Tri-set” model makes user adjustments fast, sure and convenient.
- Single factory-calibrated setpoints available from 5 mA to 950 mA.

Compatible with Standard Equipment

- Applicable on single- and three-phase systems.
- Ideal for use with shunt trip breakers.
- Magnetically isolated from monitored circuit and control power.

UL/cUL and CE Approved

- Accepted worldwide.

Insulation Breakdown Monitoring

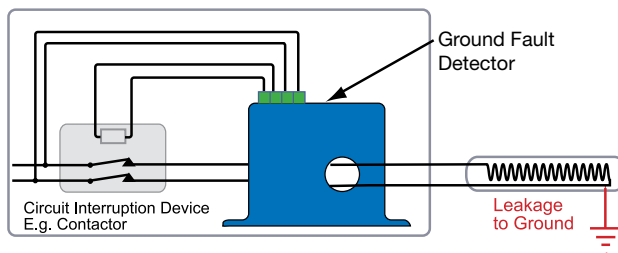

- For additional Application Examples, go to www.nktechnologies.com/applications

“Zero Sum” Operating Principle:

In three-phase delta and wye systems, under normal conditions current in the ‘hot’ leg of a two-wire load is equal in magnitude but opposite in sign to the current in the neutral leg. As a result, the electromagnetic fields surrounding these two conductors cancel, producing a “zero sum current.” As soon as current leaks to ground (fault condition) the two currents become imbalanced and a net magnetic field results. AG Series detectors monitor this field and trip alarm contacts when the leakage rises above setpoint.



Solid-state Outputs



Mechanical Outputs

Available Models

AG Series with Solid-state Outputs offer the benefit of reliable, long-lasting solid-state switches. Solid-state design provides unlimited switch operating life, superior resistance to shock and vibration, zero off-state leakage, high switch speeds and high input-output isolation. Available in solid-core case with screw terminals.

AG Series with Mechanical Outputs are available in solid-core cases with a choice between a N.O. or N.C. SPST latching relay and a SPDT Form C relay with auto-reset. All mechanical models can be ordered with factory-set, field-adjustable setpoint or with a “Tri-set” option, which provides three factory-set setpoints. A noise immunity option is available for applications in harsh EMI/RFI environments.

Output Tables

Normally Energized Models (-FS Option and -ENE Option)

Protection from faults and control power loss.

	Control Power Applied		
	No Power	No Fault	Fault
N.C. Normally Closed	closed	open	closed
N.O. Normally Open	open	closed	open

Normally De-energized Models (-NF and -DEN Options)

Protection from faults only when power is applied.

	Control Power Applied		
	No Power	No Fault	Fault
N.C. Normally Closed	closed	closed	open
N.O. Normally Open	open	open	closed

Latching Models (-LA Option)

power up initially in the rest (normal) mode. If there is a fault condition or the test button is pushed, the output contacts will change state and latch. The output will remain latched regardless of whether the fault is cleared or control power is removed. To reset the output apply a momentary contact across “reset” terminals.

OEMs Test & Evaluation Units for OEMs
Free program expedites evaluation process. See page 3 for details.



Ground Fault Protection Dimensions

Solid-State

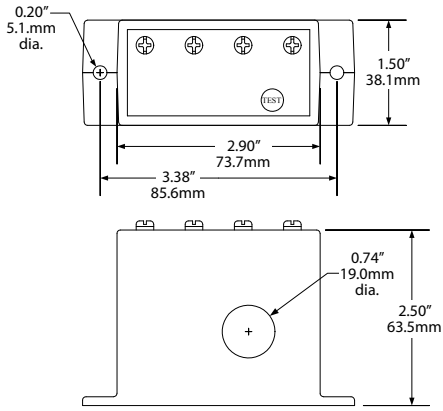

Mechanical

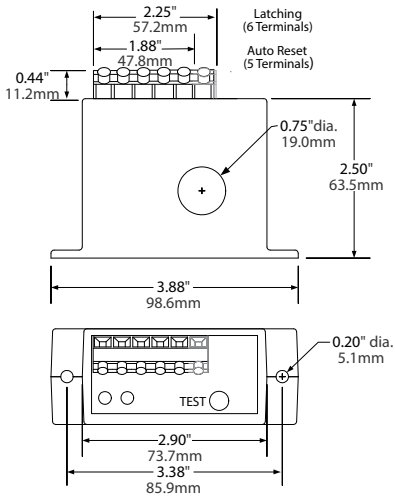

Connections

AG Series Solid-State Switch

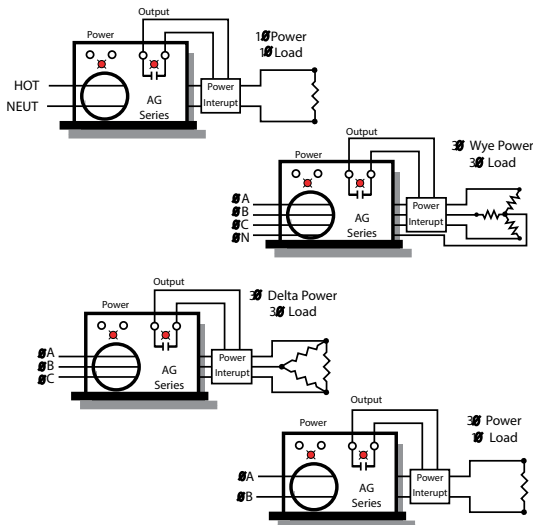
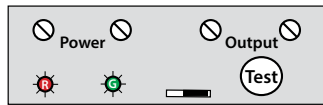

AG Series Mechanical Relay

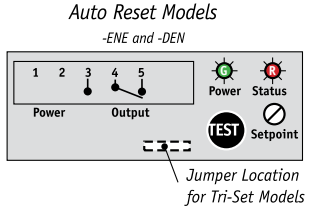
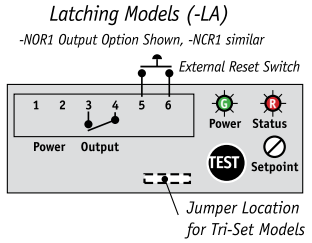

Ground Fault Protection Specifications



Power Supply	<ul style="list-style-type: none"> • 120 VAC (66–132 V) • 24 VAC/DC (19–29 V) • Green LED = Power On indication 	
Power Consumption	2 VA max.	
Setpoint Range	Factory-calibrated models (specify when ordering): <ul style="list-style-type: none"> • AG1: 5–100 mA (005–100) • AG2: 80–950 mA (080–950) TR3 “Tri-set” models (field jumper select): <ul style="list-style-type: none"> • AG3: 5, 10, or 30 mA 	
	SOLID-STATE OUTPUT MODELS	MECHANICAL OUTPUT MODELS
Output	Isolated solid-state relay	Electromechanical SPDT relay
Output Rating	<ul style="list-style-type: none"> • Solid-state AC Switch 1 A @ 240 VAC • Solid-state DC Switch 0.15 A @ 30 VDC 	<ul style="list-style-type: none"> • Auto Reset: SPDT Relay 1 A @ 125 VAC, 2 A @ 30 VDC • Latching: SPST Relay 1 A @ 125 VAC, 2 A @ 30 VDC
Off-state Leakage	<ul style="list-style-type: none"> • <10 micro A (N.O.) • <2.5 mA (N.C.) 	none
Response Time	<ul style="list-style-type: none"> • 200 ms @ 5% above trip point • 60 ms @ 50% above trip point • 15 ms @ 500% above trip point 	
Time Delay	None	
Isolation Voltage	UL listed to 1270 VAC, tested to 5 KV	
Frequency Range	50–400 Hz (monitored circuit)	
Noise Immunity	N/A	<ul style="list-style-type: none"> • EMI/RFI shielding • Power supply noise filtering
Case	UL94 V-0 Flammability Rated	
Environmental	-4 to 122°F (-20 to 50°C) 0–95% RH, non-condensing	
Listings	UL/cUL, CE	

Ground Fault Protection Ordering Information

Solid-state Output Models

Sample Model Number: AG1-NOAC-120-FS-005
 Ground fault detector with normally open solid-state contact output, 120 VAC power supply, 5 mA trip point, failsafe version.

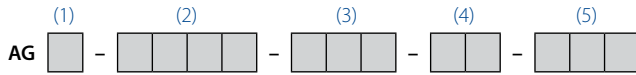

(1) Setpoint Range

1	5–100 mA factory set
2*	80–950 mA factory set
3	5/10/30 mA jumper set

*Not UL recognized in any configuration.

(2) Output Type

NOAC	Normally Open, 1 A @ 240 VAC
NCAC	Normally Closed, 1 A @ 240 VAC
NODC	Normally Open, 0.15 A @ 30 VDC
NCDC	Normally Closed, 0.15 A @ 30 VDC

(3) Power Supply

120	120 VAC
24U*	24 VAC/DC
240*	240 VAC

*Not UL recognized in any configuration.

(4) Options

FS	Normally energized
NF	Normally de-energized

(5) Setpoint

TR3	Tri-set
005 to 950	Factory set trip point in mA

Mechanical Output Models

Sample Model Number: AG1-NOR1-120-LA-005
 Ground fault detector with normally open SPST latching relay output, 120 VAC power supply and 5 mA trip point.

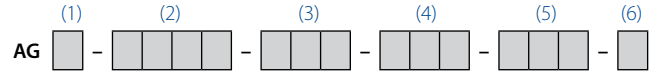

(1) Setpoint Range

1	5–100 mA factory set
2	80–950 mA factory set
3	5/10/30 mA jumper set

(2) Output Type

NCR1	Normally Closed SPST Relay Form B (Available only with -LA option)
NOR1	Normally Open SPST Relay Form A (Available only with -LA option)
SDT1	SPDT Relay (Form C) with auto-reset (Available only with -DEN and -ENE options)

(3) Power Supply

120	120 VAC
24U	24 VAC/DC

(4) Options

ENE	Normally energized, auto-reset (SDT1 output only)
DEN	Normally de-energized, auto-reset (SDT1 output only)
LA	Latching (NOR1 and NCR1)

(5) Setpoint

TR3	Tri-set
005 to 950	Factory set trip point in mA

(6) Noise Immunity

N	Noise immunity
	None (blank)

OEMs Test & Evaluation Units for OEMs
 Free program expedites evaluation process. See page 3 for details.

