

**Input:** 100 Ω to 10,000 Ω Bridges, 0.5 mV/V to 40 mV/V, 1-10 VDC Excitation

**Output:** 0-1 V to ±10 V or 0-2 mA to 4-20 mA (Sink or Source)

- Use Internal or External Calibration Resistor
- Sense Lead Compensation
- Easy to Cancel or Tare Out Deadweights
- Drive up to Four 350 Ω Bridges
- Non-Interactive Zero and Span
- One Minute Setup for Hundreds of I/O Ranges
- Removable Plugs for Faster Installation
- Full 3-Way Input/Output/Power Isolation
- Input and Output LoopTracker® LEDs
- Adjustable Excitation Power Supply

**Applications**

- Load Cell Weighing Systems and Scales
- Strain Gauge Pressure Sensors and Transducers
- Tanks, Scales, Extruder Melt Pressure, Crane Loads

**Strain Gauge Input Ranges**

100 Ω to 10,000 Ω bridges at 10 VDC  
 Up to four 350 Ω bridges at 10 VDC  
 Minimum: 0 to 5 mV range 0.5 mV/V sensitivity  
 Maximum: 0 to 400 mV range 40 mV/V sensitivity  
 Millivolt output range is determined by the sensor sensitivity (mV/V) and the excitation voltage  
 mV/V sensitivity X excitation voltage = total mV range

**Input Impedance**

200 kΩ typical

**Common Mode Rejection**

100 dB minimum

**Excitation Voltage**

Switch selectable: 0-10 VDC in 1 V increments  
 Maximum output: 10 VDC maximum at 120 mA  
 Drive capability: Up to four 350 Ω bridges at 10 VDC  
 Fine adjustment: ±5% via multi-turn potentiometer  
 Stability: ±0.01% per °C

**Calibration Resistor**

Provisions for internal and external calibration resistor.  
 Test switch shunts calibration resistor across one arm of bridge. Specify value of internal calibration resistor, if required.

**Sense Lead Compensation**

Better than ±0.01% per 1 Ω change in leadwire resistance  
 Maximum leadwire resistance: 10 Ω with 350 Ω at 10 VDC

**LoopTracker**

Variable brightness LEDs for input/output loop level and status

**DC Output Ranges**

Voltage (10 mA max.): 0-1 VDC to 0-10 VDC  
 Bipolar voltage (±10 mA max.): ±5 VDC or ±10 VDC  
 Current: 0-2 mAADC to 0-20 mAADC  
 Compliance, drive at 20 mA: 20 V, 1000 Ω drive  
 Current output can be selectively wired for sink or source

**Output Calibration**

Multi-turn zero and span potentiometers  
 ±15% of span adjustment range typical  
 Zero offset switch: ±100% of span in 15% increments

**Output Ripple and Noise**

Less than 10 mVRMS ripple and noise

**Linearity**

Better than ±0.1% of span

**Ambient Temperature Range and Stability**

-10°C to +60°C operating ambient  
 Better than ±0.02% of span per °C stability

**Response Time**

70 milliseconds typical (14.2 Hz)  
 DF option: 10 millisecond response time typical (100 Hz)  
 Contact factory for custom response times

**Isolation**

1200 VRMS minimum  
 Full isolation: power to input, power to output, input to output



**Housing and Connectors**

IP 40, requires installation in panel or enclosure  
 For use in Pollution Degree 2 Environment  
 Mount vertically to a 35 mm DIN rail  
 Four 4-terminal removable connectors  
 14 AWG max wire size

**Dimensions**

0.89" W x 4.62" H x 4.81" D  
 22.5 mm W x 117 mm H x 122 mm D  
 Height includes connectors

**Power**

Standard: 85-265 VAC, 50/60 Hz or 60-300 VDC  
 D option: 9-30 VDC (either polarity) or 10-32 VAC  
 Power: 2 to 5 Watts depending on number of load cells

**Description**

The APD 4059 CR accepts an input from one to four strain gauges, bridge type sensors, load cells, or pressure transducers. It filters, amplifies, and converts the resulting millivolt signal into the selected DC voltage or current output that is linearly related to the input.

The full 3 way (input, output, power) isolation makes this module useful for ground loop elimination, common mode signal rejection or noise pickup reduction.

The adjustable excitation power supply generates a stable source of voltage to drive from one to four 350 Ω (or greater) devices. Sense lead circuitry is included to cancel the effects of leadwire resistance, if required.

Input, output, excitation and zero offset are field configurable, via external rotary and slide switches. Offsets up to ±100% of span can be used to cancel sensor offsets or non-zero deadweights (taring). Non-interactive zero and span simplifies calibration.

The APD 4059 CR can be specified with varying degrees of filtering to tailor the response time to the application. Consult factory for assistance.

Model	Input	Output	Power
APD 4059 CR	Field configurable. Specify following if factory is to set switches Bridge mV/V or mV range Excitation voltage	Field configurable. Specify following if factory is to set switches Output range Output type (V or mA)	85-265 VAC or 60-300 VDC
APD 4059 CR D	Calibration resistor value, if required		9-30 VDC or 10-32 VAC

**Options—add to end of model number**

- DF** 10 millisecond response time, or consult factory. DF option will cause output noise levels to be greater than standard specifications.
- U** Conformal coating for moisture resistance



Connect mA Output for Sink or Source

1 2 3 4

Removable Plugs

Hundreds of Range Selections

5 6 7 8

Output LoopTracker LED

Test Switch for Calibration Resistor

Zero and Span for Output

Input LoopTracker LED

Internal/External Calibration Resistor

Connect up to 4 Load Cells

9 10 11 12

13 14 15 16

Universal Power

See Wiring Diagrams on Page 3

**Sink/Source Versatility**

For maximum versatility the APD 4059 CR milliamp output can be selectively wired for sinking or sourcing. This allows connection to any type of mA input receiving device.

**LoopTracker**

API exclusive features include two LoopTracker LEDs (green for input, red for output) that vary in intensity with changes in the process input and output signals. These provide a quick visual picture of your process loop at all times and can greatly aid in saving time during initial startup and/or troubleshooting.

**Calibration Resistor**

The APD 4059 CR has provisions for an internal or external calibration resistor. The internal calibration resistor value can be specified at time of order, or the resistor can be customer installed or changed.

For load cells with their own internal calibration resistor, terminals are provided for wiring connections. The test switch is used to shunt the calibration resistor across one arm of bridge to simulate strain.

**Accessory—order as separate line item**

- API BP4** Spare removable 4 terminal plug, black

**Precautions**

**WARNING!** All wiring must be performed by a qualified electrician or instrumentation engineer. See diagram for terminal designations and wiring examples. Consult factory for assistance.

**WARNING!** Avoid shock hazards! Turn signal input, output, and power off before connecting or disconnecting wiring, or removing or installing module.

**Précautions**

**ATTENTION!** Tout le câblage doit être effectué par un électricien ou ingénieur en instrumentation qualifié. Voir le diagramme pour désignations des bornes et des exemples de câblage. Consulter l'usine pour assistance.

**ATTENTION!** Éviter les risques de choc! Fermez le signal d'entrée, le signal de sortie et l'alimentation électrique avant de connecter ou de déconnecter le câblage, ou de retirer ou d'installer le module.

**Internal Calibration Resistor**

The APD 4059 CR has provisions for an internal shunt/calibration resistor. It can be ordered with the module or installed by the user. The resistor value should match what is specified by the transducer manufacturer.

The calibration resistor can be installed or changed in the field if required by following the procedure below.

1. Remove all power from the APD 4059 CR, unplug all connectors, and remove unit from DIN rail.
2. Using a small flat-blade screwdriver remove the front panel as shown below.
3. Note the locations of the seven tabs attaching the side cover.
4. Using a small flat-blade screwdriver gently pry the tab ends away from the housing. Start with the large tab at the rear of the unit, and work towards the front while gently pulling up on the side cover.
5. When all tabs are unlatched, remove the side cover.
6. To remove the calibration resistor (if one was installed), pull it out of its holder. The calibration resistor should have the leads cut and bent to fit the calibration resistor holder.
7. Align the side cover and snap into place making sure all seven tabs are engaged. Snap front cover back into place. Reinstall unit.



**Internal Calibration Resistor**

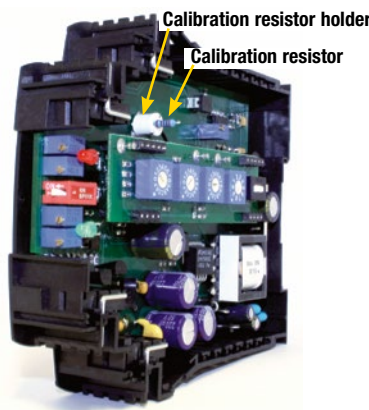

**Range Selection**

It is generally easier to select ranges before installing the module on the DIN rail. The tables list available settings for excitation voltages, ranges and offsets. Any custom range settings will be listed on the module's serial number label

Rotary switches and a slide switches on the side of the module are used to select input and output ranges to match your application.

- Switch A: Excitation voltage
- Switch B: Input range
- Switch C: Input offset
- Switch D: Output range
- Switch E: Set to "V" for voltage output or Set to "I" for current output

Determine how much output in millivolts the load cell will produce at full load. Multiply the manufacturer's mV/V sensitivity specification by the applied excitation voltage.

For example, a load cell rated for 3 mV/V sensitivity using 10 VDC excitation will produce an output of 0 to 30 mV for load variations from 0 to 100%.

$3 \text{ mV/V sensitivity} \times 10 \text{ VDC excitation} = 30 \text{ mV range}$

**Switch A Excitation Voltage**

Refer to the sensor manufacturer's recommendations to determine what excitation voltage to use.

Set Excitation rotary switch A to desired excitation voltage.

After installation the Excitation fine adjust potentiometer may be used to precisely trim this voltage, if desired.

Excitation	Switch A
10 V	A
9 V	9
8 V	8
7 V	7
6 V	6
5 V	5
4 V	4
3 V	3
2 V	2
1 V	1
0 V	0

**I/O Range Selection Switches B, D, E**

1. From the table at the bottom of the page, find the rotary switch combination that matches your I/O ranges and set rotary switches B and D.
2. For taring, deadweight, zero offset, or a bipolar sensor refer to the "Offset Switch C" section below. Otherwise set switch C to zero.
3. Set switch E to "V" for voltage output or "I" for current output.
4. For ranges that fall between the listed ranges use the next highest setting and trim the output signal with the zero and span potentiometers as described in the Calibration section.

**Using Offset Switch C**

Offset switch C allows canceling or taring of non-zero deadweights or other sensor offsets such as:

- Compensate for tare weights or scale deadweight to get zero output when a load is on the platform.
- Compensate for low-output sensors (e.g., less than 1 mV/V) that may have large zero offsets. Switch C can realign the zero control so it has enough range to produce a zero output.
- Raising the offset to allow calibration of bipolar sensors such as  $\pm 10 \text{ mV}$ .
- Lowering the offset to compensate for elevated input ranges such as 10-20 mV.

1. Switch C does not interact with any other switch and is the only switch needed to correct zero offsets. Its only purpose is to adjust or cancel effects of the low end of the input range not corresponding nominally to 0 mV. Setting this switch to "0" results in no offset.
2. To RAISE the output zero, rotate switch C from "1" thru "7", until the Zero control can be set for your application.
3. To LOWER the output zero, rotate switch C from "9" thru "F", until the Zero control can be set for your application.
4. If switch positions are changed, repeat the calibration procedure on the last page.

Offset % of Span	Switch C
105%	7
90%	6
75%	5
60%	4
45%	3
30%	2
15%	1
0%	0
-15%	9
-30%	A
-45%	B
-60%	C
-75%	D
-90%	E
-105%	F

Output	0-1 V	0-2 V	0-4 V	1-5 V	0-5 V	0-8 V	2-10 V	0-10 V	$\pm 5 \text{ V}$	$\pm 10 \text{ V}$	0-2 mA	0-4 mA	0-8 mA	2-10 mA	0-10 mA	0-16 mA	4-20 mA	0-20 mA
Switches	BCDE	BCDE	BCDE	BCDE	BCDE	BCDE	BCDE	BCDE	BCDE	BCDE	BCDE	BCDE	BCDE	BCDE	BCDE	BCDE	BCDE	BCDE
Input	BCDE	BCDE	BCDE	BCDE	BCDE	BCDE	BCDE	BCDE	BCDE	BCDE	BCDE	BCDE	BCDE	BCDE	BCDE	BCDE	BCDE	BCDE
0-5 mV	200V	208V	201V	206V	209V	202V	207V	203V	204V	205V	200I	208I	201I	206I	209I	202I	207I	203I
0-10 mV	A00V	A08V	A01V	A06V	A09V	A02V	A07V	A03V	A04V	A05V	A00I	A08I	A01I	A06I	A09I	A02I	A07I	A03I
0-20 mV	300V	308V	301V	306V	309V	302V	307V	303V	304V	305V	300I	308I	301I	306I	309I	302I	307I	303I
0-25 mV	600V	608V	601V	606V	609V	602V	607V	603V	604V	605V	600I	608I	601I	606I	609I	602I	607I	603I
0-30 mV	E00V	E08V	E01V	E06V	E09V	E02V	E07V	E03V	E04V	E05V	E00I	E08I	E01I	E06I	E09I	E02I	E07I	E03I
0-40 mV	B00V	B08V	B01V	B06V	B09V	B02V	B07V	B03V	B04V	B05V	B00I	B08I	B01I	B06I	B09I	B02I	B07I	B03I
0-50 mV	000V	008V	001V	006V	009V	002V	007V	003V	004V	005V	000I	008I	001I	006I	009I	002I	007I	003I
0-100 mV	800V	808V	801V	806V	809V	802V	807V	803V	804V	805V	800I	808I	801I	806I	809I	802I	807I	803I
0-120 mV	F00V	F08V	F01V	F06V	F09V	F02V	F07V	F03V	F04V	F05V	F00I	F08I	F01I	F06I	F09I	F02I	F07I	F03I
0-200 mV	100V	108V	101V	106V	109V	102V	107V	103V	104V	105V	100I	108I	101I	106I	109I	102I	107I	103I
0-250 mV	400V	408V	401V	406V	409V	402V	407V	403V	404V	405V	400I	408I	401I	406I	409I	402I	407I	403I
0-300 mV	C00V	C08V	C01V	C06V	C09V	C02V	C07V	C03V	C04V	C05V	C00I	C08I	C01I	C06I	C09I	C02I	C07I	C03I
0-400 mV	900V	908V	901V	906V	909V	902V	907V	903V	904V	905V	900I	908I	901I	906I	909I	902I	907I	903I

## Internal Calibration Resistor

The APD 4059 CR is available with a user-specified internal calibration resistor. The sensor manufacturer should provide the percentage of full-scale output for the transducer when using the internal resistor for calibration.

## Load Cells with a Built-In Calibration Resistor

Refer to the load cell manufacturer's specifications and the wiring diagram when connecting a transducer with its own internal calibration resistor.

The transducer's calibration resistor wires are connected to terminals 5 and 11 on the APD 4059 CR.

If the transducer only has one calibration resistor wire, connect it to terminal 5.

No internal calibration resistor should be installed. See instructions on previous page for removal.

## Signal Input Terminals

Refer to strain gauge manufacturer's data sheet for wire color-coding and identification. Polarity must be observed when connecting inputs.

CAUTION: Do not miswire the load cell and never short the excitation leads together. This will cause internal damage to the module.

## No Sense Leads

When no sense leads are used, jumper terminals 6 and 12.

## With Sense Leads

Some bridges or load cells have one or two sense leads. Sense leads allow the APD 4059 CR to compensate for leadwire resistance effects. Connect the sense leads if used. Polarity must be observed.

Never jumper terminals 6 and 12 when using sense leads.

## Output

Polarity must be observed when connecting the signal output. If your device accepts a current input, determine if it provides power to the current loop or if it must be powered by the APD module. Use a multi-meter to check for voltage at the device's input terminals. Typical voltage may be 9-24 VDC.

Type of Device for Output	- Term.	+ Term.
mA (current) input device that powers the current loop. Switch E set to "I".	2 (-)	3 (+)
mA (current) input device that is passive. APD module provides the loop power. Switch E set to "I".	3 (-)	4 (+20 V)
Measuring/recording device accepts a voltage input. Switch E set to "V".	3 (-)	4 (+)

## Module Power

Check model/serial number label for module operating voltage to make sure it matches available power. Connect power last. When using DC power, either polarity is acceptable, but for consistency with similar API products, positive (+) can be wired to terminal 13 and negative (-) can be wired to terminal 16. Connect I/O wiring before power wiring.

CAUTION: To maintain full isolation avoid wiring DC power supplies in common with output and unit power.

## Mounting to a DIN Rail

Install module vertically on a 35 mm DIN rail in a protective enclosure away from heat sources. Do not block air flow. Allow 1" (25 mm) above and below housing vents for air circulation.

1. Tilt front of module downward and position against DIN rail.
2. Clip lower mount to bottom edge of DIN rail.
3. Push front of module upward until upper mount snaps into place.

## Removal

1. Push up on the bottom back of the module.
2. Tilt front of module downward to release upper mount from top edge of DIN rail.
3. The module can now be removed from the DIN rail.

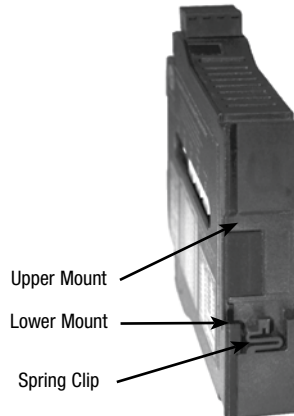

To avoid damage to the module, do not make any connections to unused terminals

Wire terminal torque  
0.5 to 0.6 Nm or  
4.4 to 5.3 in-lbs

Shield wires should be grounded at one end only

Colors shown are an example only. See manufacturer's specifications for wiring designations.

To maintain full isolation avoid combining power supplies in common with input, output, or unit power.

If your load cell has an internal calibration resistor, remove the calibration resistor inside the APD4059 CR

API maintains a constant effort to upgrade and improve its products. Specifications are subject to change without notice. See [api-usa.com](http://api-usa.com) for latest product information. Consult factory for your specific requirements.



WARNING: This product can expose you to chemicals including nickel, which are known to the State of California to cause cancer or birth defects or other reproductive harm. For more information go to [www.P65Warnings.ca.gov](http://www.P65Warnings.ca.gov)

Cu 60/75°C  
conductors  
14 AWG  
max.

## Output Wiring

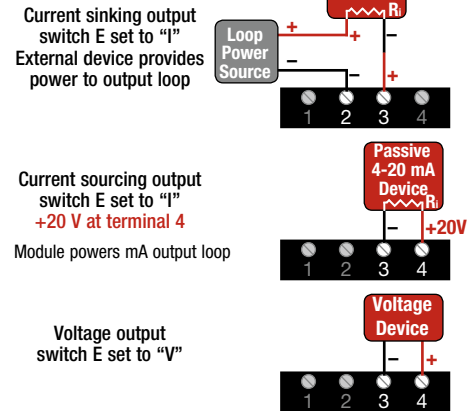

## No Sense Leads

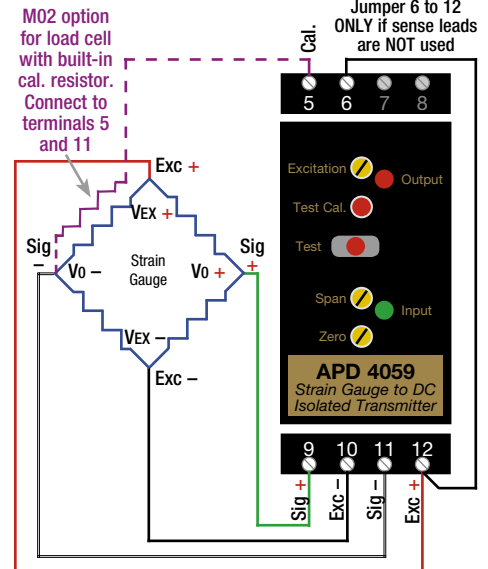

## With Sense Leads

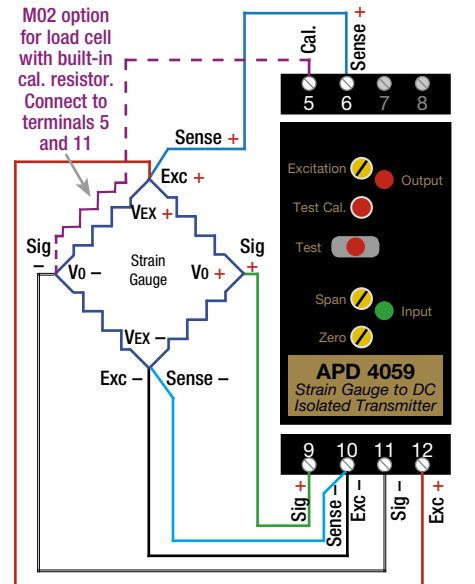

## Module Power

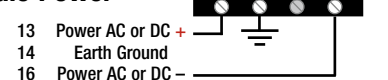



**Basic Calibration**

The Zero, Span, and Excitation potentiometers are used to calibrate the output. This calibration procedure does not account for offsets or tare weights. If your system has an offset, tare weight or deadweight, refer to the Offset Switch procedure.

Note: Perform the following calibration procedure any time switch settings are changed.

To achieve optimum results, the system should be calibrated using an accurate bridge simulator, pressure calibrator, or calibration weights depending on the application.

1. Apply power to the module and allow a minimum 20 minute system warm up time.
2. Using an accurate voltmeter across terminals 10 and 12, adjust the Excitation voltage potentiometer on front of the APD 4059 CR for the exact voltage desired.
3. With the input set at zero or the minimum, adjust the front Zero pot for a zero or low-end output (for example, 4 mA for a 4-20 mA output or -10 V with a ±10V output).
4. The zero pot may also be adjusted for a zero reading on the output display instrumentation, e.g. control system or process indicator. Adjusting the zero pot this way eliminates calibration errors in the display instrumentation.
5. Set the input at maximum, and then adjust the Span pot for the exact maximum output desired. The Span control should only be adjusted when the input signal is at its maximum.

**Calibration with a Calibration Resistor**

Use this calibration procedure if your APD 4059 CR was ordered with a calibration resistor, if you installed your own calibration resistor, or if your sensor has its own internal calibration resistor.

Note: Perform the following calibration procedure any time switch settings are changed.

If your sensor has an internal calibration resistor, no calibration resistor should be installed in the APD 4059 CR.

The sensor manufacturer should provide the percentage of full-scale output for the transducer when using a calibration resistor. This is often 80% of maximum output.

1. Apply power to the module and allow a minimum 20 minute system warm up time.
2. Using an accurate voltmeter across terminals 10 and 12, adjust the Excitation voltage potentiometer on front of the APD 4059 CR for the exact voltage desired.
3. With the input set at zero or the minimum, adjust the Zero potentiometer on front of the APD 4059 CR for a zero or low-end output (for example, 4 mA for a 4-20 mA output).
4. The zero pot may also be adjusted for a zero reading on the output display instrumentation, e.g. control system or process indicator. Adjusting the zero pot this way eliminates calibration errors in the display instrumentation.
5. Set the APD 4059 CR Test toggle switch to the Test position. The calibration resistor is switched into the circuit to unbalance the bridge.
6. Adjust the span pot to the for the % output specified by the transducer manufacturer. This is often 80% of maximum output.
7. Return the Test switch to the opposite position and readjust the zero pot if necessary.

**Operation**

Strain gauges and load cells are normally passive devices that are commonly referred to as “bridges” due to their four-resistor Wheatstone bridge configuration. These sensors require a precise excitation source to produce an output that is directly proportional to the load, pressure, etc. that is applied to the sensor.

The exact output of the sensor (measured in millivolts) is determined by the sensitivity of the sensor (mV/V) and the excitation voltage applied.

An additional input, the sense lead, monitors the voltage drop in the sensor leads and automatically compensates the excitation voltage at the module in order to maintain a constant excitation voltage at the sensor.

The APD 4059 CR provides the excitation voltage to the sensor and receives the resulting millivolt signal in return. This input signal is filtered and amplified, then offset, if required, and passed to the output stage. Depending on the output configuration selected, a DC voltage or current output is generated.

**GREEN LoopTracker® Input LED** – Provides a visual indication that a signal is being sensed by the input circuitry of the module. It also indicates the input signal level by changing in intensity as the process changes from minimum to maximum. If the LED fails to illuminate, or fails to change in intensity as the process changes, this may indicate a problem with module power or signal input wiring.

**RED LoopTracker Output LED** – Provides a visual indication that the output signal is functioning. It becomes brighter as the input and the corresponding output change from minimum to maximum. For current outputs, the RED LED will only light if the output loop current path is complete. For either current or voltage outputs, failure to illuminate or a failure to change in intensity as the process changes may indicate a problem with the module power or signal output wiring.

**Diagnostic Voltage Measurements**

Using a meter with at least 10 megaohm input impedance, measure the voltage coming from the strain gauge at the locations shown. Sensitivity is measured in mV/V.

Positive Meter Lead	Negative Meter Lead	Meter Reading No pressure/load	Meter Reading Full pressure/load
+ Exc.	- Exc.	Excitation Voltage	Excitation Voltage
+ Sig.	- Exc.	+ ½ Excitation Voltage	½ Excitation Voltage + (½ x Excitation Voltage x Sensitivity)
- Sig.	- Exc.	+ ½ Excitation Voltage	½ Excitation Voltage - (½ x Excitation Voltage x Sensitivity)
+ Sig.	- Sig.	Zero Volts	Excitation Voltage x Sensitivity

**Typical Wiring Color Codes for Load Cells**

Always consult manufacturer. Exceptions and/or custom wire colors exist!

Manufacturer	+ Exc.	- Exc.	+ Signal	- Signal	Shield	+ Sense	- Sense	Manufacturer	+ Exc.	- Exc.	+ Signal	- Signal	Shield	+ Sense	- Sense
A & D	Red	White	Green	Blue	Yellow			Nikkei	Red	Black	Green	White	Bare		
Allegany	Green	Black	White	Red	Bare			OmegaDyne	Red, D, F	Blk., C, E	Green A	White B	Bare		
American/Amcell	Green	Black	White	Red	Bare			Pennsylvania	Orange	Blue	Green	White	Bare		
Artech	Red	Black	Green	White	Bare			Philips	Red	Blue	Green	Gray	Bare		
Beowulf	Green	Black	White	Red	Bare			Presage Promotion	Blue	White	Red	Black	Yellow		
B LH	Green	Black	White	Red	Yellow			Revere	Green	Black	White	Red	Orange		
Cardinal	Green	Black	White	Red	Bare			Revere	Red	Black	Green	White	Orange		
Celtron	Red	Black	Green	White	Bare			Rice Lake	Red	Black	Green	White	Bare		
Digi Matex	Red	White	Green	Yellow	Silver			Sensortronic	Red	Black	Green	White	Bare		
Dillon (DQ+)	Green	White	Black	Red	Orange			Sensortronic (col.)	Green	Black	White	Red	Bare		
Electroscale	Red	Black	Green	White	Bare			Sensotec/Honeywell	Red	Black	White	Green	Bare		
Entran	Red	Black	Yel./Grn.	White				Sentran	Red	Black	Green	White	Bare		
EverGreen	Green	Black	White	Red	Bare			SMD	Red	Black	White	Green	Bare		
Flintec	Green	Black	White	Red	Yellow			Strainert	Red	Black	Green	White	Bare		
Force Measurement	Red	Black	Green	White	Bare			Stellar STI	Red	Black	White	Green	Bare		
Futek	Red	Black	Green	White				Stellar STI	Red	Black	Green	White	Bare		
General Sensor	Red	Black	Green	White	Bare			Stellar STI	A	D	B	C	Bare		
GSE	Red	Black	White	Green	Bare			Stellar STI	A, B	C, D	F	E	Bare		
HBM	Green	Black	White	Red	Yellow			T-Hydraulics	Red	Black	Green	White	Bare		
HBM (PLC/SBE)	Red	Black	Green	White	Yellow			Tedea Huntleigh	Green	Black	Red	White	Bare	Blue	Brown
Interface	Red	Black	Green	White	Bare			Thames Side	Red	Blue	Green	Yellow	Bare		
Kubota	Red	White	Green	Blue	Yellow			Toledo	Green	Black	White	Red	Yellow		
LeBow	Red	Black	Green	White	Bare			Totalcomp	Red	Black	Green	White	Bare		
Mettler Toledo	White	Blue	Green	Black	Orange	Yellow	Red	Transducer Tech.	Red A	Black D	Green C	White B	Bare G		
National Scale	Green	Black	White	Red	Yellow			Transducers Inc.	Red	Black	Green	White	Orange		
NCI	Red	Black	White	Green	Bare	Yellow	Blue	Weigh-Tronix	Green	Black	White	Red	Or./Wh.	Yellow	Blue