

Input: 0-50 mV to ±10 VDC, 0-500 µA to 4-20 mA DC, Potentiometer, T/C, RTD, Thermistor, or Custom
Output: 0-1 V to 0-10 V, ±5 V, ±10 V, 0-2 mA to 4-20 mA, Reverse Acting Optional

[Quick Link: api-usa.com/8000](http://api-usa.com/8000)

- One Model Covers All Common Sensors
- Free Setup—No Computer or Software Needed
- Zero and Span for Output
- Full 1200 V Isolation
- Input LoopTracker® LED, Output Test Function
- Built-In Loop Power Supply for Sink/Source Output

Applications

- Convert/Isolate DC Sensors for PLC Input, Control and/or Validation
- Interface DC Sensors with Panel Meters, PLCs, Recorders, Data Acq., DCS, & SCADA Systems

Input Types, Field Selectable

DC volts 35 ranges from ±25 mVDC to ±10 VDC
 DC mA 20 ranges from ±0.5 mA DC to ±20 mA DC
 Potentiometer: 100 Ω min. to 1 Mega Ω max.
 1, 2, or 4 volt excitation
 T/Cs: J, K, T, E, R, S, N, B, C, D, G, M, P
 Full ANSI temperature ranges
 Automatic CJC
 Burnout: upscale, downscale, last valid output
 RTDs: 2, 3, or 4 wire, 10 Ω to 8000 Ω RTDs
 4 wire with or without current rotation
 Cu-10, Cu-100, Ni-100, Ni-120,
 Ni-Fe-500, Ni-Fe-1000, Ni-Fe-2000,
 Pt-10, Pt-25, Pt-50, Pt-100, Pt-200,
 Pt-470, Pt-500, Pt-1000
 Thermistors: 44004/44033 2.252 kΩ at 25°C
 44005/44030 3.000 kΩ at 25°C
 44007/44034 5.000 kΩ at 25°C
 44006/44031 10.00 kΩ at 25°C
 44008/44032 30.00 kΩ at 25°C
 YSI 400 2.252 kΩ at 25°C
 Spectrum 1003k 1 kΩ
 Custom: Provide sensor specifications, temperature curve data, and temperature range

LoopTracker

Variable brightness green LED indicates input level and status

Status LED

Yellow LED for setup and operational status

DC Output Ranges, Field Selectable

Voltage: 0-1 V, 0-2 V, 0-4 V, 0-5 V, 1-5 V, 0-8 V, 0-10 V,
 2-10 V, ±5 VDC, ±10 VDC
 Current: 0-2 mA, 0-4 mA, 0-8 mA, 0-10 mA, 2-10 mA,
 0-16 mA, 0-20 mA, 4-20 mA
 20 V compliance, 1000 Ω at 20 mA

Reverse Acting Output, Factory Set

R option: Reverse acting output
 increasing input = decreasing output signal
 Reverse acting models cannot be converted to direct acting

Output Calibration

Zero and span set by using up/down buttons, ±10% range

Output Loop Power Supply

20 VDC nom., regulated, 25 mA DC, <10 mVrms max. ripple
 May be selectively wired for sinking or sourcing mA output

Output Test

Front push button switch enables/disables test level output
 Adjustable 0-100% of span via up/down buttons

Output Resolution

18 bit

Output Ripple and Noise

Less than ±0.2% of span

Accuracy

±0.1°C input accuracy, 0.001°C input resolution

Ambient Temperature Range and Stability

-10°C to +60°C operating ambient
 Better than ±0.02% of span per °C stability

Response Time

300 milliseconds typical

Isolation

Full 3-way isolation: input, output, power, 1200 VRMS min.
 600 VACp or 600 VDC common mode protection
 75 dB minimum common mode rejection
 Simultaneous 50 Hz and 60 Hz rejection



[Applications Link](http://api-usa.com/apps)
api-usa.com/apps

Free Factory I/O Setup!

Housing and Connectors

IP 40, requires vertical installation on a 35 mm DIN rail inside a panel or enclosure
 For use in Pollution Degree 2 Environment
 Four 4-terminal removable connectors, 14 AWG max. wire size

Power

85-265 VAC, 50/60 Hz or 60-300 VDC, 3 W maximum
 D versions: 9-30 VDC or 10-32 VAC 50/60 Hz, 3 W maximum

Dimensions

Height includes connectors
 0.89" W x 4.62" H x 4.81" D (22.5 x 117 x 122 mm)

Description

The APD 8000 accepts a DC, potentiometer, thermocouple, RTD or thermistor input and provides an optically isolated and linearized DC voltage or current output. The input is sampled, digitally converted (and linearized for temperature sensors), and then passed through an optocoupler to the output stage.
 Full 3 way isolation (input, output, power) make this module useful for ground loop elimination, common mode signal rejection, and noise pickup reduction.

The input type and range, and output type and range are field configurable. This provides a versatile solution that works with all commonly available sensors.

Microprocessor-based linearization uses 41 to 55 segments or up to a 14th order polynomial depending on the sensor type.

The input type is set with switches and its range is configured using front buttons, a multimeter and an input simulator.

The low noise 18 bit analog output is isolated and can be set up for common voltage and milliamp output types.

How to Order

Models are field rangeable. If I/O is not specified, default settings are type J thermocouple, 0-500°C, 4-20 mA output. For free setup specify the following.

DC: Range and mV, volts, or mA
 Temperature: Range in °F or °C (for temperature input)
 T/C: Thermocouple type, burnout setting
 RTD: Model/type, resistance, curve, number of wires
 If 4 wire: with or without current rotation
 Thermistor: Sensor model/type, resistance
 Custom: Complete sensor data over temperature range
 Output: Range and type (mV, V, mA)

Model	Description	Power
APD 8000	Universal input to DC output	85-265 VAC, 50/60 Hz or 60-300 VDC
APD 8000 D	isolated transmitter	9-30 VDC or 10-32 VAC

Sink or Source mA Output 1 2 3 4 Removable Plugs

5 6 7 8

Setup and Status LED

Adjustable Output Test Function

Zero and Span for Output

Input LoopTracker LED

Universal Input



See Wiring Diagrams on Next Page

Universal Power

Output Sink/Source Versatility

Standard on the APD 8000 is a 20 VDC loop excitation supply for the milliamp output. The output can be selectively wired for sinking or sourcing allowing use with a powered or unpowered milliamp device.

LoopTracker

An API exclusive feature includes a green LoopTracker LED that varies in intensity with changes in the process input signal.

It provides a quick visual picture of your process input at all times and can greatly aid in saving time during initial startup and troubleshooting.

Output Test

An API exclusive feature includes an output test switch to provide a fixed output (independent of the input) when pressed. The output test greatly aids in saving time during initial startup and/or troubleshooting.

The test output level is adjustable from 0 to 100% of the output span.

Options and Accessory

Options—add to end of model number

- NC5** 5 point NIST traceable calibration certificate
- NC11** 11 point NIST traceable calibration certificate
- U** Conformal coating for moisture resistance
- R** Reverse acting output

Accessory—order as separate line item

- API BP4** Spare removable 4 terminal plug, black

Note: An appropriate simulator and a multimeter are required for setup.

Free Setup: We can set up your I/O ranges at no extra charge. See the configuration worksheet on page 8. Please provide the exact sensor type, input range, and output range on your order.

Precautions

WARNING! All wiring must be performed by a qualified electrician or instrumentation engineer. See diagram for terminal designations and wiring examples. Consult factory for assistance.

WARNING! Avoid shock hazards! Turn signal input, output, and power off before connecting or disconnecting wiring, or removing or installing module.

Précautions

ATTENTION! Tout le câblage doit être effectué par un électricien ou ingénieur en instrumentation qualifié. Voir le diagramme pour désignations des bornes et des exemples de câblage. Consulter l'usine pour assistance.

ATTENTION! Éviter les risques de choc! Fermez le signal d'entrée, le signal de sortie et l'alimentation électrique avant de connecter ou de déconnecter le câblage, ou de retirer ou d'installer le module.

API maintains a constant effort to upgrade and improve its products. Specifications are subject to change without notice. See api-usa.com for latest product information. Consult factory for your specific requirements.

WARNING: This product can expose you to chemicals including nickel, which are known to the State of California to cause cancer or birth defects or other reproductive harm. For more information go to www.P65Warnings.ca.gov

Range Selection

Select ranges before installation. A thermistor input or a 4 wire RTD with current rotation input requires changing an internal jumper. Use the tables on the next pages to select the I/O ranges and jumper settings. The module side label lists output ranges. Ranges can also be found at api-usa.com/8000

Check the model/serial number label for module power, options, or custom range information. A custom range uses switch settings described in the Custom Range Table on page 7.

Models with R reverse acting output use the same switch settings, except the output range is reversed (4-20 mA is 20-4 mA).

1. Set switches A, B, and C from the table to set input type and range.
2. Set switches D and E from the table to set the output range and set switch E: V for voltage or I for current output.

For output ranges that fall between the listed ranges use the next highest setting. The output can be trimmed using the Output Level Adjustment procedure.

Electrical Connections

See wiring diagrams at right. A multimeter and a signal or temperature simulator are required for setup. Observe polarity. If the output does not function, check wiring and polarity.

The power supplies are fuse protected and the unit may be returned to API for fuse replacement.

Input

The sensor input is connected as shown in the wiring diagrams at right. If a custom input was specified, see the model/serial number label for sensor type, range, or options. You device must provide loop power for a milliamp input.

Output

For milliamp ranges, determine if your device provides power to the current loop or if the loop must be powered by the APD module. Typical voltage may be 9-24 VDC at your device's terminals if it provides power to the loop.

Module Power

Check model/serial number label for module operating voltage to make sure it matches available power.

When using DC power, either polarity is acceptable, but for consistency with similar API products, positive (+) can be wired to terminal 13 and negative (-) can be wired to terminal 16.

Range Calibration

Note: Perform the following calibration procedure any time switch settings are changed.

1. Connect a multimeter to the output terminals 2 and 3, or 3 and 4 depending on output type. See wiring diagram at right.
2. Connect an appropriate VDC, mADC, potentiometer or temperature simulator to the input of the module.
3. Connect power to the unit (terminals 13, 14, and 16) and apply power to the module.
4. Wait until the yellow Status LED blinks (once per second).

Low End Input Calibration

5. Use the simulator to apply the low end of the input signal.
6. Push the **Set** button to store the low end input value.
7. The Status LED will turn on to indicate the reading was saved.
8. Use the **Up** and **Down** buttons to adjust the output to the desired low output reading. For example: 4 mA for a 4-20 mA output or -10 V for a ±10V output.
9. Press and release the **Set** button to store the low output.







High End Input Calibration

10. Wait until the yellow Status LED blinks (once per second).
11. Use the simulator to apply the high end of the input signal.

12. Push the **Set** button to store the high end input value.
13. The Status LED will turn on to indicate the reading was saved.
14. Use the **Up** and **Down** buttons to adjust the output to the desired high output reading (i.e. 20 mA for a 4-20 mA output).
15. Press and release the **Set** button to store the high output.

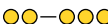
Blinking Yellow LED Setup Error Codes

If an error occurred or invalid selection was made, the yellow Status LED blinks an error code. Check switches A, B, C, and input wiring.

- | | |
|---------------------------------------|--|
| 2 1 Invalid sensor selected |  |
| 2 2 Invalid pot. excitation selected |  |
| 2 3 Invalid RTD selected |  |
| 2 4 Invalid thermistor selected |  |
| 2 5 Invalid T/C selected |  |
| 2 6 Invalid direct DC selected |  |
| 2 7 Invalid input setting (Zero>Span) |  |

Output Test Level Adjustment

16. Wait until the Status LED turns on and stays on.
 17. Use the **Up** and **Down** buttons to adjust the test output to the desired level (i.e. 12 mA for a 4-20 mA output).
 18. Press and release the **Set** button to store the test output.
 19. Wait until the Status LED starts blinks once per second.
 20. To change any value, turn off the power and repeat steps 1 to 19.
- Saving Setup**
21. Press and release the **Set** button to store the settings in memory. The Status LED will turn on during the storing process.
 22. Once the Status LED turns off, setup and configuration is complete. Turn off power to the unit and remove the simulator and multimeter.

Adjusting Output After Installation

It may be necessary to fine-tune the output signal after installation to account for offset, tare, lead length, or operating temperature.

1. Press and release the **Set** button. This will turn on the yellow Status LED.
2. Use the **Up** and **Down** buttons to adjust the output to the desired level. The Status LED will turn off during the adjustment.
3. Once the desired output level has been met, press and release the **Set** button to save the adjustment. The "Status" LED will flash indicating that the change has been made.

The unit has an auto Zero/Span detection for knowing which to adjust. If the output signal is greater than 50% of the Span, the unit will adjust the output signal Span.

If the output signal is less than 50% of the Span, the unit will adjust the output signal Zero.

Changing I/O Setup

To reset the unit back to factory default without changing any input switch settings press and hold the **Set** button while the module is being powered up.

If you change the input switch setting, the unit will automatically start in setup mode to allow you to calibrate and store your new configuration.

Output Test Function

When the **Test** button is pressed it will drive the output with a known good signal that can be used as a diagnostic aid during initial start-up or troubleshooting. When pressed again, the output will return to normal. The button allows hands-free operation of the Test Mode.

The Test level can be adjusted by using the **Up** and **Down** buttons. The level can be saved by pressing the **Set** button, or it can default back to the setup value by not pressing the **Set** button.

Operation

The APD 8000 accepts a DC, potentiometer, or temperature input and provides a linearized and optically isolated DC voltage or current output.

The green LoopTracker® input LED provides a visual indication that a signal is being sensed by the input circuitry of the module. It also indicates the input signal strength by changing in intensity as the process changes from minimum to maximum.

If the LED fails to illuminate, or fails to change in intensity as the process changes, check the module power or signal input wiring.







The yellow status LED provides a visual indication of operational modes.

- | | |
|--------------------|--------------------------|
| Normal operation: | Off |
| Push-to-Test mode: | Steadily on |
| User setup mode: | Blinking once per second |

Note that it may be difficult to see the LEDs under bright lighting conditions.

Blinking Yellow LED Operational Error Codes

If an error occurs during operation, the yellow Status LED blinks an error code. Check sensor, wiring, or consult factory.

- | | |
|--|---|
| 1 1 Analog-digital converter out-of-range |  |
| 1 2 Sensor under range |  |
| 1 3 Sensor over range |  |
| 1 4 CJC sensor abnormal range |  |
| 1 5 CJC failure |  |
| 1 6 Hard ADC out-of-range |  |
| 1 7 Sensor hard fault: Open circuit, hard ADC fault, or hard CJC fault |  |

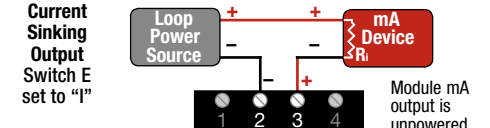
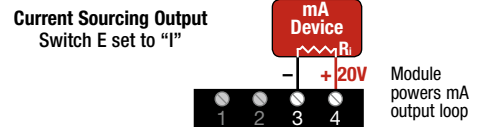

Yellow status LED Setup: blinks once per second
Off: normal operation
2 digit code: error code

To maintain full isolation and avoid malfunctions, do not connect power supplies in common with input, output or unit power.

Do not connect any devices to unused terminals.

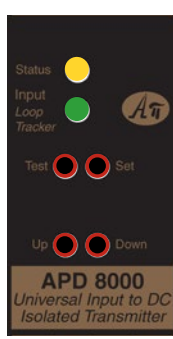

Green LoopTracker LED brightness varies with input level

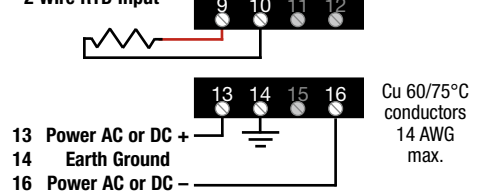



To avoid damage to the module, do not make any connections to unused terminals

Wire terminal torque
0.5 to 0.6 Nm or
4.4 to 5.3 in-lbs

Mounting to a DIN Rail

Install module vertically on a 35 mm DIN rail in a protective enclosure away from heat sources. Do not block air flow. Allow 1" (25 mm) above and below housing vents for air circulation.

1. Tilt front of module downward and clip the lower mount with spring clips to the bottom edge of DIN rail.
2. Push front of module upward until upper mount snaps into place.

Removal

Avoid shock hazards! Turn signal input, output, and power off before removing module.

1. Push up on bottom back of module.
2. Tilt the front of module downward to release upper mount from top edge of DIN rail.
3. The module can now be removed from the DIN rail.



Range Table: Thermocouple

Switch A	7	Single-Ended setting for grounded or ungrounded thermocouples
Switch A	8	Differential setting for ungrounded thermocouples or thermocouples operating in the negative mV range (typically below 0°C)

For models with "R" option, output ranges are reversed

Thermocouple	Output Switches	±10 V	0-10 V	±5 V	2-10 V	0-8 V	0-5 V	1-5 V	0-4 V	0-2 V	0-1 V	0-20 mA	4-20 mA	0-16 mA	0-10 mA	2-10 mA	0-8 mA	0-4 mA	0-2 mA
		BCDE	BCDE	BCDE	BCDE	BCDE	BCDE	BCDE	BCDE	BCDE	BCDE	BCDE	BCDE	BCDE	BCDE	BCDE	BCDE	BCDE	BCDE
B	Upscale	195V	193V	194V	197V	192V	199V	196V	191V	198V	190V	193I	197I	192I	199I	196I	191I	198I	190I
B	Downscale	1A5V	1A3V	1A4V	1A7V	1A2V	1A9V	1A6V	1A1V	1A8V	1A0V	1A3I	1A7I	1A2I	1A9I	1A6I	1A1I	1A8I	1A0I
B	None	1B5V	1B3V	1B4V	1B7V	1B2V	1B9V	1B6V	1B1V	1B8V	1B0V	1B3I	1B7I	1B2I	1B9I	1B6I	1B1I	1B8I	1B0I
C	Upscale	295V	293V	294V	297V	292V	299V	296V	291V	298V	290V	293I	297I	292I	299I	296I	291I	298I	290I
C	Downscale	2A5V	2A3V	2A4V	2A7V	2A2V	2A9V	2A6V	2A1V	2A8V	2A0V	2A3I	2A7I	2A2I	2A9I	2A6I	2A1I	2A8I	2A0I
C	None	2B5V	2B3V	2B4V	2B7V	2B2V	2B9V	2B6V	2B1V	2B8V	2B0V	2B3I	2B7I	2B2I	2B9I	2B6I	2B1I	2B8I	2B0I
D	Upscale	395V	393V	394V	397V	392V	399V	396V	391V	398V	390V	393I	397I	392I	399I	396I	391I	398I	390I
D	Downscale	3A5V	3A3V	3A4V	3A7V	3A2V	3A9V	3A6V	3A1V	3A8V	3A0V	3A3I	3A7I	3A2I	3A9I	3A6I	3A1I	3A8I	3A0I
D	None	3B5V	3B3V	3B4V	3B7V	3B2V	3B9V	3B6V	3B1V	3B8V	3B0V	3B3I	3B7I	3B2I	3B9I	3B6I	3B1I	3B8I	3B0I
E	Upscale	495V	493V	494V	497V	492V	499V	496V	491V	498V	490V	493I	497I	492I	499I	496I	491I	498I	490I
E	Downscale	4A5V	4A3V	4A4V	4A7V	4A2V	4A9V	4A6V	4A1V	4A8V	4A0V	4A3I	4A7I	4A2I	4A9I	4A6I	4A1I	4A8I	4A0I
E	None	4B5V	4B3V	4B4V	4B7V	4B2V	4B9V	4B6V	4B1V	4B8V	4B0V	4B3I	4B7I	4B2I	4B9I	4B6I	4B1I	4B8I	4B0I
G	Upscale	595V	593V	594V	597V	592V	599V	596V	591V	598V	590V	593I	597I	592I	599I	596I	591I	598I	590I
G	Downscale	5A5V	5A3V	5A4V	5A7V	5A2V	5A9V	5A6V	5A1V	5A8V	5A0V	5A3I	5A7I	5A2I	5A9I	5A6I	5A1I	5A8I	5A0I
G	None	5B5V	5B3V	5B4V	5B7V	5B2V	5B9V	5B6V	5B1V	5B8V	5B0V	5B3I	5B7I	5B2I	5B9I	5B6I	5B1I	5B8I	5B0I
J	Upscale	695V	693V	694V	697V	692V	699V	696V	691V	698V	690V	693I	697I	692I	699I	696I	691I	698I	690I
J	Downscale	6A5V	6A3V	6A4V	6A7V	6A2V	6A9V	6A6V	6A1V	6A8V	6A0V	6A3I	6A7I	6A2I	6A9I	6A6I	6A1I	6A8I	6A0I
J	None	6B5V	6B3V	6B4V	6B7V	6B2V	6B9V	6B6V	6B1V	6B8V	6B0V	6B3I	6B7I	6B2I	6B9I	6B6I	6B1I	6B8I	6B0I
K	Upscale	795V	793V	794V	797V	792V	799V	796V	791V	798V	790V	793I	797I	792I	799I	796I	791I	798I	790I
K	Downscale	7A5V	7A3V	7A4V	7A7V	7A2V	7A9V	7A6V	7A1V	7A8V	7A0V	7A3I	7A7I	7A2I	7A9I	7A6I	7A1I	7A8I	7A0I
K	None	7B5V	7B3V	7B4V	7B7V	7B2V	7B9V	7B6V	7B1V	7B8V	7B0V	7B3I	7B7I	7B2I	7B9I	7B6I	7B1I	7B8I	7B0I
M	Upscale	895V	893V	894V	897V	892V	899V	896V	891V	898V	890V	893I	897I	892I	899I	896I	891I	898I	890I
M	Downscale	8A5V	8A3V	8A4V	8A7V	8A2V	8A9V	8A6V	8A1V	8A8V	8A0V	8A3I	8A7I	8A2I	8A9I	8A6I	8A1I	8A8I	8A0I
M	None	8B5V	8B3V	8B4V	8B7V	8B2V	8B9V	8B6V	8B1V	8B8V	8B0V	8B3I	8B7I	8B2I	8B9I	8B6I	8B1I	8B8I	8B0I
N	Upscale	995V	993V	994V	997V	992V	999V	996V	991V	998V	990V	993I	997I	992I	999I	996I	991I	998I	990I
N	Downscale	9A5V	9A3V	9A4V	9A7V	9A2V	9A9V	9A6V	9A1V	9A8V	9A0V	9A3I	9A7I	9A2I	9A9I	9A6I	9A1I	9A8I	9A0I
N	None	9B5V	9B3V	9B4V	9B7V	9B2V	9B9V	9B6V	9B1V	9B8V	9B0V	9B3I	9B7I	9B2I	9B9I	9B6I	9B1I	9B8I	9B0I
P	Upscale	A95V	A93V	A94V	A97V	A92V	A99V	A96V	A91V	A98V	A90V	A93I	A97I	A92I	A99I	A96I	A91I	A98I	A90I
P	Downscale	AA5V	AA3V	AA4V	AA7V	AA2V	AA9V	AA6V	AA1V	AA8V	AA0V	AA3I	AA7I	AA2I	AA9I	AA6I	AA1I	AA8I	AA0I
P	None	AB5V	AB3V	AB4V	AB7V	AB2V	AB9V	AB6V	AB1V	AB8V	AB0V	AB3I	AB7I	AB2I	AB9I	AB6I	AB1I	AB8I	AB0I
R	Upscale	B95V	B93V	B94V	B97V	B92V	B99V	B96V	B91V	B98V	B90V	B93I	B97I	B92I	B99I	B96I	B91I	B98I	B90I
R	Downscale	BA5V	BA3V	BA4V	BA7V	BA2V	BA9V	BA6V	BA1V	BA8V	BA0V	BA3I	BA7I	BA2I	BA9I	BA6I	BA1I	BA8I	BA0I
R	None	BB5V	BB3V	BB4V	BB7V	BB2V	BB9V	BB6V	BB1V	BB8V	BB0V	BB3I	BB7I	BB2I	BB9I	BB6I	BB1I	BB8I	BB0I
S	Upscale	C95V	C93V	C94V	C97V	C92V	C99V	C96V	C91V	C98V	C90V	C93I	C97I	C92I	C99I	C96I	C91I	C98I	C90I
S	Downscale	CA5V	CA3V	CA4V	CA7V	CA2V	CA9V	CA6V	CA1V	CA8V	CA0V	CA3I	CA7I	CA2I	CA9I	CA6I	CA1I	CA8I	CA0I
S	None	CB5V	CB3V	CB4V	CB7V	CB2V	CB9V	CB6V	CB1V	CB8V	CB0V	CB3I	CB7I	CB2I	CB9I	CB6I	CB1I	CB8I	CB0I
T	Upscale	D95V	D93V	D94V	D97V	D92V	D99V	D96V	D91V	D98V	D90V	D93I	D97I	D92I	D99I	D96I	D91I	D98I	D90I
T	Downscale	DA5V	DA3V	DA4V	DA7V	DA2V	DA9V	DA6V	DA1V	DA8V	DA0V	DA3I	DA7I	DA2I	DA9I	DA6I	DA1I	DA8I	DA0I
T	None	DB5V	DB3V	DB4V	DB7V	DB2V	DB9V	DB6V	DB1V	DB8V	DB0V	DB3I	DB7I	DB2I	DB9I	DB6I	DB1I	DB8I	DB0I

Range Table: 2 Wire and 3 Wire RTDs

For models with "R" option, output ranges are reversed

2 Wire RTD	Output	±10 V	0-10 V	±5 V	2-10 V	0-8 V	0-5 V	1-5 V	0-4 V	0-2 V	0-1 V	0-20 mA	4-20 mA	0-16 mA	0-10 mA	2-10 mA	0-8 mA	0-4 mA	0-2 mA	
	Switches	ABCDE	ABCDE	ABCDE	ABCDE	ABCDE	ABCDE	ABCDE	ABCDE	ABCDE	ABCDE	ABCDE	ABCDE	ABCDE	ABCDE	ABCDE	ABCDE	ABCDE	ABCDE	ABCDE
Type	Curve	ABCDE	ABCDE	ABCDE	ABCDE	ABCDE	ABCDE	ABCDE	ABCDE	ABCDE	ABCDE	ABCDE	ABCDE	ABCDE	ABCDE	ABCDE	ABCDE	ABCDE	ABCDE	ABCDE
Cu-10	0.00427	2185V	2183V	2184V	2187V	2182V	2189V	2186V	2181V	2188V	2180V	2183I	2187I	2182I	2189I	2186I	2181I	2188I	2180I	
Cu-100	0.00427	2285V	2283V	2284V	2287V	2282V	2289V	2286V	2281V	2288V	2280V	2283I	2287I	2282I	2289I	2286I	2281I	2288I	2280I	
Ni-100	0.00618	2385V	2383V	2384V	2387V	2382V	2389V	2386V	2381V	2388V	2380V	2383I	2387I	2382I	2389I	2386I	2381I	2388I	2380I	
Ni-120	0.00672	2485V	2483V	2484V	2487V	2482V	2489V	2486V	2481V	2488V	2480V	2483I	2487I	2482I	2489I	2486I	2481I	2488I	2480I	
Ni-Fe-500	0.00518	2585V	2583V	2584V	2587V	2582V	2589V	2586V	2581V	2588V	2580V	2583I	2587I	2582I	2589I	2586I	2581I	2588I	2580I	
Ni-Fe-1000	0.00527	2685V	2683V	2684V	2687V	2682V	2689V	2686V	2681V	2688V	2680V	2683I	2687I	2682I	2689I	2686I	2681I	2688I	2680I	
Ni-Fe-2000	0.00527	2785V	2783V	2784V	2787V	2782V	2789V	2786V	2781V	2788V	2780V	2783I	2787I	2782I	2789I	2786I	2781I	2788I	2780I	
Pt-10	0.00385	28A5V	28A3V	28A4V	28A7V	28A2V	28A9V	28A6V	28A1V	28A8V	28A0V	28A3I	28A7I	28A2I	28A9I	28A6I	28A1I	28A8I	28A0I	
Pt-10	0.003911	28B5V	28B3V	28B4V	28B7V	28B2V	28B9V	28B6V	28B1V	28B8V	28B0V	28B3I	28B7I	28B2I	28B9I	28B6I	28B1I	28B8I	28B0I	
Pt-10	0.003916	28C5V	28C3V	28C4V	28C7V	28C2V	28C9V	28C6V	28C1V	28C8V	28C0V	28C3I	28C7I	28C2I	28C9I	28C6I	28C1I	28C8I	28C0I	
Pt-10	0.003926	28D5V	28D3V	28D4V	28D7V	28D2V	28D9V	28D6V	28D1V	28D8V	28D0V	28D3I	28D7I	28D2I	28D9I	28D6I	28D1I	28D8I	28D0I	
Pt-25	0.003926	29D5V	29D3V	29D4V	29D7V	29D2V	29D9V	29D6V	29D1V	29D8V	29D0V	29D3I	29D7I	29D2I	29D9I	29D6I	29D1I	29D8I	29D0I	
Pt-50	0.00385	2AA5V	2AA3V	2AA4V	2AA7V	2AA2V	2AA9V	2AA6V	2AA1V	2AA8V	2AA0V	2AA3I	2AA7I	2AA2I	2AA9I	2AA6I	2AA1I	2AA8I	2AA0I	
Pt-50	0.003911	2AB5V	2AB3V	2AB4V	2AB7V	2AB2V	2AB9V	2AB6V	2AB1V	2AB8V	2AB0V	2AB3I	2AB7I	2AB2I	2AB9I	2AB6I	2AB1I	2AB8I	2AB0I	
Pt-50	0.003916	2AC5V	2AC3V	2AC4V	2AC7V	2AC2V	2AC9V	2AC6V	2AC1V	2AC8V	2AC0V	2AC3I	2AC7I	2AC2I	2AC9I	2AC6I	2AC1I	2AC8I	2AC0I	
Pt-50	0.003926	2AD5V	2AD3V	2AD4V	2AD7V	2AD2V	2AD9V	2AD6V	2AD1V	2AD8V	2AD0V	2AD3I	2AD7I	2AD2I	2AD9I	2AD6I	2AD1I	2AD8I	2AD0I	
Pt-100	0.00385	2BA5V	2BA3V	2BA4V	2BA7V	2BA2V	2BA9V	2BA6V	2BA1V	2BA8V	2BA0V	2BA3I	2BA7I	2BA2I	2BA9I	2BA6I	2BA1I	2BA8I	2BA0I	
Pt-100	0.003911	2BB5V	2BB3V	2BB4V	2BB7V	2BB2V	2BB9V	2BB6V	2BB1V	2BB8V	2BB0V	2BB3I	2BB7I	2BB2I	2BB9I	2BB6I	2BB1I	2BB8I	2BB0I	
Pt-100	0.003916	2BC5V	2BC3V	2BC4V	2BC7V	2BC2V	2BC9V	2BC6V	2BC1V	2BC8V	2BC0V	2BC3I	2BC7I	2BC2I	2BC9I	2BC6I	2BC1I	2BC8I	2BC0I	
Pt-100	0.003926	2BD5V	2BD3V	2BD4V	2BD7V	2BD2V	2BD9V	2BD6V	2BD1V	2BD8V	2BD0V	2BD3I	2BD7I	2BD2I	2BD9I	2BD6I	2BD1I	2BD8I	2BD0I	
Pt-200	0.00385	2CA5V	2CA3V	2CA4V	2CA7V	2CA2V	2CA9V	2CA6V	2CA1V	2CA8V	2CA0V	2CA3I	2CA7I	2CA2I	2CA9I	2CA6I	2CA1I	2CA8I	2CA0I	
Pt-200	0.003911	2CB5V	2CB3V	2CB4V	2CB7V	2CB2V	2CB9V	2CB6V	2CB1V	2CB8V	2CB0V	2CB3I	2CB7I	2CB2I	2CB9I	2CB6I	2CB1I	2CB8I	2CB0I	
Pt-200	0.003916	2CC5V	2CC3V	2CC4V	2CC7V	2CC2V	2CC9V	2CC6V	2CC1V	2CC8V	2CC0V	2CC3I	2CC7I	2CC2I	2CC9I	2CC6I	2CC1I	2CC8I	2CC0I	
Pt-200	0.003926	2CD5V	2CD3V	2CD4V	2CD7V	2CD2V	2CD9V	2CD6V	2CD1V	2CD8V	2CD0V	2CD3I	2CD7I	2CD2I	2CD9I	2CD6I	2CD1I	2CD8I	2CD0I	
Pt-470	0.003926	2DD5V	2DD3V	2DD4V	2DD7V	2DD2V	2DD9V	2DD6V	2DD1V	2DD8V	2DD0V	2DD3I	2DD7I	2DD2I	2DD9I	2DD6I	2DD1I	2DD8I	2DD0I	
Pt-500	0.00385	2EA5V	2EA3V	2EA4V	2EA7V	2EA2V	2EA9V	2EA6V	2EA1V	2EA8V	2EA0V	2EA3I	2EA7I	2EA2I	2EA9I	2EA6I	2EA1I	2EA8I	2EA0I	
Pt-500	0.003911	2EB5V	2EB3V	2EB4V	2EB7V	2EB2V	2EB9V	2EB6V	2EB1V	2EB8V	2EB0V	2EB3I	2EB7I	2EB2I	2EB9I	2EB6I	2EB1I	2EB8I	2EB0I	
Pt-500	0.003916	2EC5V	2EC3V	2EC4V	2EC7V	2EC2V	2EC9V	2EC6V	2EC1V	2EC8V	2EC0V	2EC3I	2EC7I	2EC2I	2EC9I	2EC6I	2EC1I	2EC8I	2EC0I	
Pt-500	0.003926	2ED5V	2ED3V	2ED4V	2ED7V	2ED2V	2ED9V	2ED6V	2ED1V	2ED8V	2ED0V	2ED3I	2ED7I	2ED2I	2ED9I	2ED6I	2ED1I	2ED8I	2ED0I	
Pt-1000	0.00375	2F95V	2F93V	2F94V	2F97V	2F92V	2F99V	2F96V	2F91V	2F98V	2F90V	2F93I	2F97I	2F92I	2F99I	2F96I	2F91I	2F98I	2F90I	
Pt-1000	0.00385	2FA5V	2FA3V	2FA4V	2FA7V	2FA2V	2FA9V	2FA6V	2FA1V	2FA8V	2FA0V	2FA3I	2FA7I	2FA2I	2FA9I	2FA6I	2FA1I	2FA8I	2FA0I	
Pt-1000	0.003911	2FB5V	2FB3V	2FB4V	2FB7V	2FB2V	2FB9V	2FB6V	2FB1V	2FB8V	2FB0V	2FB3I	2FB7I	2FB2I	2FB9I	2FB6I	2FB1I	2FB8I	2FB0I	
Pt-1000	0.003916	2FC5V	2FC3V	2FC4V	2FC7V	2FC2V	2FC9V	2FC6V	2FC1V	2FC8V	2FC0V	2FC3I	2FC7I	2FC2I	2FC9I	2FC6I	2FC1I	2FC8I	2FC0I	
Pt-1000	0.003926	2FD5V	2FD3V	2FD4V	2FD7V	2FD2V	2FD9V	2FD6V	2FD1V	2FD8V	2FD0V	2FD3I	2FD7I	2FD2I	2FD9I	2FD6I	2FD1I	2FD8I	2FD0I	
3 Wire RTD	Output	±10 V	0-10 V	±5 V	2-10 V	0-8 V	0-5 V	1-5 V	0-4 V	0-2 V	0-1 V	0-20 mA	4-20 mA	0-16 mA	0-10 mA	2-10 mA	0-8 mA	0-4 mA	0-2 mA	
	Switches	ABCDE	ABCDE	ABCDE	ABCDE	ABCDE	ABCDE	ABCDE	ABCDE	ABCDE	ABCDE	ABCDE	ABCDE	ABCDE	ABCDE	ABCDE	ABCDE	ABCDE	ABCDE	ABCDE
Type	Curve	ABCDE	ABCDE	ABCDE	ABCDE	ABCDE	ABCDE	ABCDE	ABCDE	ABCDE	ABCDE	ABCDE	ABCDE	ABCDE	ABCDE	ABCDE	ABCDE	ABCDE	ABCDE	ABCDE
Cu-10	0.00427	3185V	3183V	3184V	3187V	3182V	3189V	3186V	3181V	3188V	3180V	3183I	3187I	3182I	3189I	3186I	3181I	3188I	3180I	
Cu-100	0.00427	3285V	3283V	3284V	3287V	3282V	3289V	3286V	3281V	3288V	3280V	3283I	3287I	3282I	3289I	3286I	3281I	3288I	3280I	
Ni-100	0.00618	3385V	3383V	3384V	3387V	3382V	3389V	3386V	3381V	3388V	3380V	3383I	3387I	3382I	3389I	3386I	3381I	3388I	3380I	
Ni-120	0.00672	3485V	3483V	3484V	3487V	3482V	3489V	3486V	3481V	3488V	3480V	3483I	3487I	3482I	3489I	3486I	3481I	3488I	3480I	
Ni-Fe-500	0.00518	3585V	3583V	3584V	3587V	3582V	3589V	3586V	3581V	3588V	3580V	3583I	3587I	3582I	3589I	3586I	3581I	3588I	3580I	
Ni-Fe-1000	0.00527	3685V	3683V	3684V	3687V	3682V	3689V	3686V	3681V	3688V	3680V	3683I	3687I	3682I	3689I	3686I	3681I	3688I	3680I	
Ni-Fe-2000	0.00527	3785V	3783V	3784V	3787V	3782V	3789V	3786V	3781V	3788V	3780V	3783I	3787I	3782I	3789I	3786I	3781I	3788I	3780I	
Pt-10	0.00385	38A5V	38A3V	38A4V	38A7V	38A2V	38A9V	38A6V	38A1V	38A8V	38A0V	38A3I	38A7I	38A2I	38A9I	38A6I	38A1I	38A8I	38A0I	
Pt-10	0.003911	38B5V	38B3V	38B4V	38B7V	38B2V	38B9V	38B6V	38B1V	38B8V	38B0V	38B3I	38B7I	38B2I	38B9I	38B6I	38B1I	38B8I	38B0I	
Pt-10	0.003916	38C5V	38C3V	38C4V	38C7V	38C2V	38C9V	38C6V	38C1V	38C8V	38C0V	38C3I	38C7I	38C2I	38C9I	38C6I	38C1I	38C8I	38C0I	
Pt-10	0.003926	38D5V	38D3V	38D4V	38D7V	38D2V	38D9V	38D6V	38D1V	38D8V	38D0V	38D3I	38D7I	38D2I	38D9I	38D6I	38D1I	38D8I	38D0I	
Pt-25	0.003926	39D5V	39D3V	39D4V	39D7V	39D2V	39D9V	39D6V	39D1V	39D8V	39D0V	39D3I	39D7I	39D2I	39D9I	39D6I	39D1I	39D8I	39D0I	
Pt-50	0.00385	3AA5V	3AA3V	3AA4V	3AA7V	3AA2V	3AA9V	3AA6V	3AA1V	3AA8V	3AA0V	3AA3I	3AA7I	3AA2I	3AA9I	3AA6I	3AA1I	3AA8I	3AA0I	
Pt-50	0.003911	3AB5V	3AB3V	3AB4V	3AB7V	3AB2V	3AB9V	3AB6V	3AB1V	3AB8V	3AB0V	3AB3I	3AB7I	3AB2I	3AB9I	3AB6I	3AB1I	3AB8I	3AB0I	
Pt-50	0.003916	3AC5V	3AC3V	3AC4V	3AC7V	3AC2V	3AC9V	3AC6V	3AC1V	3AC8V	3AC0V	3AC3I	3AC7I	3AC2I	3AC9I	3AC6I	3AC1I	3AC8I	3AC0I	
Pt-50	0.003926	3AD5V	3AD3V	3AD4V	3AD7V	3AD2V	3AD9V	3AD6V	3AD1V	3AD8V	3AD0V	3AD3I	3AD7I	3AD2I	3AD9I	3AD6I	3AD1I	3AD8I	3AD0I	
Pt-100	0.00385	3BA5V	3BA3V	3BA4V	3BA7V	3BA2V	3BA9V	3BA6V	3BA1V	3BA8V	3BA0V	3BA3I	3BA7I	3BA2I	3BA9I	3BA6I	3BA1I	3BA8I	3BA0I	
Pt-100	0.003911	3BB5V	3BB3V	3BB4V	3BB7V	3BB2V	3BB9V	3BB6V	3BB1V	3BB8V	3BB0V	3BB3I	3BB7I	3BB2I	3BB9I	3BB6I	3BB1I	3BB8I	3BB0I	
Pt-100	0.003916	3BC5V	3BC3V	3BC4V	3BC7V	3BC2V	3BC9V	3BC6V	3BC1V	3BC8V	3BC0V	3BC3I	3BC7I	3BC2I	3BC9I	3BC6I	3BC1I	3BC8I	3BC0I	
Pt-100	0.003926	3BD5V	3BD3V	3BD4V	3BD7V	3BD2V	3BD9V	3BD6V	3BD1V	3BD8V	3BD0V	3BD3I	3BD7I	3BD2I	3BD9I	3BD6I	3BD1I	3BD8I	3BD0I	
Pt-200	0.00385	3CA5V	3CA3V	3CA4V	3CA7V	3CA2V	3CA9V	3CA6V	3CA1V	3CA8V	3CA0V	3CA3I	3CA7I	3CA2I	3CA9I	3CA6I	3CA1I	3CA8I	3CA0I	
Pt-200	0.003911	3CB5V	3CB3V	3CB4V	3CB7V	3CB2V	3CB9V	3CB6V	3CB1V	3CB8V	3CB0V	3CB3I	3CB7I	3CB2I	3CB9I	3CB6I	3CB1I	3CB8I	3CB0I	
Pt-200	0.003916	3CC5V	3CC3V	3CC4V	3CC7V	3CC2V</														

For models with "R" option, output ranges are reversed

4 Wire RTD	Output	±10 V	0-10 V	±5 V	2-10 V	0-8 V	0-5 V	1-5 V	0-4 V	0-2 V	0-1 V	0-20 mA	4-20 mA	0-16 mA	0-10 mA	2-10 mA	0-8 mA	0-4 mA	0-2 mA
	Switches	ABCDE	ABCDE	ABCDE	ABCDE	ABCDE	ABCDE	ABCDE	ABCDE	ABCDE	ABCDE	ABCDE	ABCDE	ABCDE	ABCDE	ABCDE	ABCDE	ABCDE	ABCDE
Type	Curve																		
Cu-10	0.00427	4185V	4183V	4184V	4187V	4182V	4189V	4186V	4181V	4188V	4180V	4183I	4187I	4182I	4189I	4186I	4181I	4188I	4180I
Cu-100	0.00427	4285V	4283V	4284V	4287V	4282V	4289V	4286V	4281V	4288V	4280V	4283I	4287I	4282I	4289I	4286I	4281I	4288I	4280I
Ni-100	0.00618	4385V	4383V	4384V	4387V	4382V	4389V	4386V	4381V	4388V	4380V	4383I	4387I	4382I	4389I	4386I	4381I	4388I	4380I
Ni-120	0.00672	4485V	4483V	4484V	4487V	4482V	4489V	4486V	4481V	4488V	4480V	4483I	4487I	4482I	4489I	4486I	4481I	4488I	4480I
Ni-Fe-500	0.00518	4585V	4583V	4584V	4587V	4582V	4589V	4586V	4581V	4588V	4580V	4583I	4587I	4582I	4589I	4586I	4581I	4588I	4580I
Ni-Fe-1000	0.00527	4685V	4683V	4684V	4687V	4682V	4689V	4686V	4681V	4688V	4680V	4683I	4687I	4682I	4689I	4686I	4681I	4688I	4680I
Ni-Fe-2000	0.00527	4785V	4783V	4784V	4787V	4782V	4789V	4786V	4781V	4788V	4780V	4783I	4787I	4782I	4789I	4786I	4781I	4788I	4780I
Pt-10	0.00385	48A5V	48A3V	48A4V	48A7V	48A2V	48A9V	48A6V	48A1V	48A8V	48A0V	48A3I	48A7I	48A2I	48A9I	48A6I	48A1I	48A8I	48A0I
Pt-10	0.003911	48B5V	48B3V	48B4V	48B7V	48B2V	48B9V	48B6V	48B1V	48B8V	48B0V	48B3I	48B7I	48B2I	48B9I	48B6I	48B1I	48B8I	48B0I
Pt-10	0.003916	48C5V	48C3V	48C4V	48C7V	48C2V	48C9V	48C6V	48C1V	48C8V	48C0V	48C3I	48C7I	48C2I	48C9I	48C6I	48C1I	48C8I	48C0I
Pt-10	0.003926	48D5V	48D3V	48D4V	48D7V	48D2V	48D9V	48D6V	48D1V	48D8V	48D0V	48D3I	48D7I	48D2I	48D9I	48D6I	48D1I	48D8I	48D0I
Pt-25	0.003926	49D5V	49D3V	49D4V	49D7V	49D2V	49D9V	49D6V	49D1V	49D8V	49D0V	49D3I	49D7I	49D2I	49D9I	49D6I	49D1I	49D8I	49D0I
Pt-50	0.00385	4AA5V	4AA3V	4AA4V	4AA7V	4AA2V	4AA9V	4AA6V	4AA1V	4AA8V	4AA0V	4AA3I	4AA7I	4AA2I	4AA9I	4AA6I	4AA1I	4AA8I	4AA0I
Pt-50	0.003911	4AB5V	4AB3V	4AB4V	4AB7V	4AB2V	4AB9V	4AB6V	4AB1V	4AB8V	4AB0V	4AB3I	4AB7I	4AB2I	4AB9I	4AB6I	4AB1I	4AB8I	4AB0I
Pt-50	0.003916	4AC5V	4AC3V	4AC4V	4AC7V	4AC2V	4AC9V	4AC6V	4AC1V	4AC8V	4AC0V	4AC3I	4AC7I	4AC2I	4AC9I	4AC6I	4AC1I	4AC8I	4AC0I
Pt-50	0.003926	4AD5V	4AD3V	4AD4V	4AD7V	4AD2V	4AD9V	4AD6V	4AD1V	4AD8V	4AD0V	4AD3I	4AD7I	4AD2I	4AD9I	4AD6I	4AD1I	4AD8I	4AD0I
Pt-100	0.00385	4BA5V	4BA3V	4BA4V	4BA7V	4BA2V	4BA9V	4BA6V	4BA1V	4BA8V	4BA0V	4BA3I	4BA7I	4BA2I	4BA9I	4BA6I	4BA1I	4BA8I	4BA0I
Pt-100	0.003911	4BB5V	4BB3V	4BB4V	4BB7V	4BB2V	4BB9V	4BB6V	4BB1V	4BB8V	4BB0V	4BB3I	4BB7I	4BB2I	4BB9I	4BB6I	4BB1I	4BB8I	4BB0I
Pt-100	0.003916	4BC5V	4BC3V	4BC4V	4BC7V	4BC2V	4BC9V	4BC6V	4BC1V	4BC8V	4BC0V	4BC3I	4BC7I	4BC2I	4BC9I	4BC6I	4BC1I	4BC8I	4BC0I
Pt-100	0.003926	4BD5V	4BD3V	4BD4V	4BD7V	4BD2V	4BD9V	4BD6V	4BD1V	4BD8V	4BD0V	4BD3I	4BD7I	4BD2I	4BD9I	4BD6I	4BD1I	4BD8I	4BD0I
Pt-200	0.00385	4CA5V	4CA3V	4CA4V	4CA7V	4CA2V	4CA9V	4CA6V	4CA1V	4CA8V	4CA0V	4CA3I	4CA7I	4CA2I	4CA9I	4CA6I	4CA1I	4CA8I	4CA0I
Pt-200	0.003911	4CB5V	4CB3V	4CB4V	4CB7V	4CB2V	4CB9V	4CB6V	4CB1V	4CB8V	4CB0V	4CB3I	4CB7I	4CB2I	4CB9I	4CB6I	4CB1I	4CB8I	4CB0I
Pt-200	0.003916	4CC5V	4CC3V	4CC4V	4CC7V	4CC2V	4CC9V	4CC6V	4CC1V	4CC8V	4CC0V	4CC3I	4CC7I	4CC2I	4CC9I	4CC6I	4CC1I	4CC8I	4CC0I
Pt-200	0.003926	4CD5V	4CD3V	4CD4V	4CD7V	4CD2V	4CD9V	4CD6V	4CD1V	4CD8V	4CD0V	4CD3I	4CD7I	4CD2I	4CD9I	4CD6I	4CD1I	4CD8I	4CD0I
Pt-470	0.003926	4DD5V	4DD3V	4DD4V	4DD7V	4DD2V	4DD9V	4DD6V	4DD1V	4DD8V	4DD0V	4DD3I	4DD7I	4DD2I	4DD9I	4DD6I	4DD1I	4DD8I	4DD0I
Pt-500	0.00385	4EA5V	4EA3V	4EA4V	4EA7V	4EA2V	4EA9V	4EA6V	4EA1V	4EA8V	4EA0V	4EA3I	4EA7I	4EA2I	4EA9I	4EA6I	4EA1I	4EA8I	4EA0I
Pt-500	0.003911	4EB5V	4EB3V	4EB4V	4EB7V	4EB2V	4EB9V	4EB6V	4EB1V	4EB8V	4EB0V	4EB3I	4EB7I	4EB2I	4EB9I	4EB6I	4EB1I	4EB8I	4EB0I
Pt-500	0.003916	4EC5V	4EC3V	4EC4V	4EC7V	4EC2V	4EC9V	4EC6V	4EC1V	4EC8V	4EC0V	4EC3I	4EC7I	4EC2I	4EC9I	4EC6I	4EC1I	4EC8I	4EC0I
Pt-500	0.003926	4ED5V	4ED3V	4ED4V	4ED7V	4ED2V	4ED9V	4ED6V	4ED1V	4ED8V	4ED0V	4ED3I	4ED7I	4ED2I	4ED9I	4ED6I	4ED1I	4ED8I	4ED0I
Pt-1000	0.00375	4F95V	4F93V	4F94V	4F97V	4F92V	4F99V	4F96V	4F91V	4F98V	4F90V	4F93I	4F97I	4F92I	4F99I	4F96I	4F91I	4F98I	4F90I
Pt-1000	0.00385	4FA5V	4FA3V	4FA4V	4FA7V	4FA2V	4FA9V	4FA6V	4FA1V	4FA8V	4FA0V	4FA3I	4FA7I	4FA2I	4FA9I	4FA6I	4FA1I	4FA8I	4FA0I
Pt-1000	0.003911	4FB5V	4FB3V	4FB4V	4FB7V	4FB2V	4FB9V	4FB6V	4FB1V	4FB8V	4FB0V	4FB3I	4FB7I	4FB2I	4FB9I	4FB6I	4FB1I	4FB8I	4FB0I
Pt-1000	0.003916	4FC5V	4FC3V	4FC4V	4FC7V	4FC2V	4FC9V	4FC6V	4FC1V	4FC8V	4FC0V	4FC3I	4FC7I	4FC2I	4FC9I	4FC6I	4FC1I	4FC8I	4FC0I
Pt-1000	0.003926	4FD5V	4FD3V	4FD4V	4FD7V	4FD2V	4FD9V	4FD6V	4FD1V	4FD8V	4FD0V	4FD3I	4FD7I	4FD2I	4FD9I	4FD6I	4FD1I	4FD8I	4FD0I

Range Table: Thermistor

Internal Jumper for Thermistor Input

To use the thermistor input, an internal jumper must be moved by following the procedure below.

1. Remove all power from the module, unplug all connectors, and remove unit from DIN rail.
2. Using a small flat-blade screwdriver remove the front panel as shown.
3. Note the locations of the seven tabs attaching the side cover.
4. Using a small flat-blade screwdriver gently pry the tab ends away from the housing. Start with the large tab at the rear of the unit, and work towards the front while gently pulling up on the side cover.
5. When all tabs are unlatched, remove the side cover.
6. Pull it out of its holder and place it in the location shown for a thermistor input.
7. Align the side cover and snap into place making sure all seven tabs are engaged. Snap front cover back into place. Reinstall unit.

Cover Removal



Internal Jumper

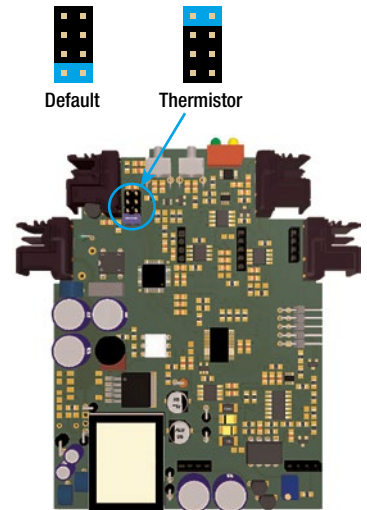

For models with "R" option, output ranges are reversed

Thermistor	Output	±10 V	0-10 V	±5 V	2-10 V	0-8 V	0-5 V	1-5 V	0-4 V	0-2 V	0-1 V	0-20 mA	4-20 mA	0-16 mA	0-10 mA	2-10 mA	0-8 mA	0-4 mA	0-2 mA
	Switches	ABCDE	ABCDE	ABCDE	ABCDE	ABCDE	ABCDE	ABCDE	ABCDE	ABCDE	ABCDE	ABCDE	ABCDE	ABCDE	ABCDE	ABCDE	ABCDE	ABCDE	ABCDE
Type	Ohms																		
44004/44033	2.252 k	6185V	6183V	6184V	6187V	6182V	6189V	6186V	6181V	6188V	6180V	6183I	6187I	6182I	6189I	6186I	6181I	6188I	6180I
44005/44030	3 k	6285V	6283V	6284V	6287V	6282V	6289V	6286V	6281V	6288V	6280V	6283I	6287I	6282I	6289I	6286I	6281I	6288I	6280I
44007/44034	5 k	6385V	6383V	6384V	6387V	6382V	6389V	6386V	6381V	6388V	6380V	6383I	6387I	6382I	6389I	6386I	6381I	6388I	6380I
44006/44031	10 k	6485V	6483V	6484V	6487V	6482V	6489V	6486V	6481V	6488V	6480V	6483I	6487I	6482I	6489I	6486I	6481I	6488I	6480I
44008/44032	30 k	6585V	6583V	6584V	6587V	6582V	6589V	6586V	6581V	6588V	6580V	6583I	6587I	6582I	6589I	6586I	6581I	6588I	6580I
YSI 400	2.252 k	6685V	6683V	6684V	6687V	6682V	6689V	6686V	6681V	6688V	6680V	6683I	6687I	6682I	6689I	6686I	6681I	6688I	6680I
Spectrum 1003	1 k	6785V	6783V	6784V	6787V	6782V	6789V	6786V	6781V	6788V	6780V	6783I	6787I	6782I	6789I	6786I	6781I	6788I	6780I

Internal Jumper for 4 Wire RTD with Current Rotation Input

To use the 4 wire RTD with current rotation input, an internal jumper must be moved by following the procedure below. This measuring method eliminates errors from parasitic millivolts generated by dissimilar metal connections.

1. Remove all power from the module, unplug all connectors, and remove unit from DIN rail.
2. Using a small flat-blade screwdriver remove the front panel as shown.
3. Note the locations of the seven tabs attaching the side cover.
4. Using a small flat-blade screwdriver gently pry the tab away from the housing. Start with the large tab at the rear of the unit, and work towards the front while gently pulling up on the side cover.
5. When all tabs are unlatched, remove the side cover.
6. Pull it out of its holder and place it in the location shown for a thermistor input.
7. Align the side cover and snap into place making sure all seven tabs are engaged. Snap front cover back into place. Reinstall unit.

Cover Removal



Internal Jumper

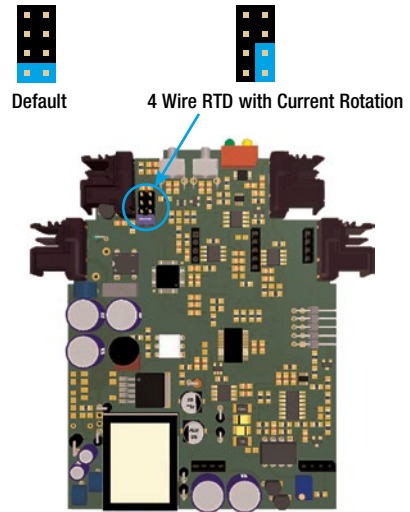

For models with "R" option, output ranges are reversed

4 Wire RTD Current Rotation	Output Switches	±10 V	0-10 V	±5 V	2-10 V	0-8 V	0-5 V	1-5 V	0-4 V	0-2 V	0-1 V	0-20 mA	4-20 mA	0-16 mA	0-10 mA	2-10 mA	0-8 mA	0-4 mA	0-2 mA
		Curve	ABCDE	ABCDE	ABCDE	ABCDE	ABCDE	ABCDE	ABCDE	ABCDE	ABCDE	ABCDE	ABCDE	ABCDE	ABCDE	ABCDE	ABCDE	ABCDE	ABCDE
Cu-10	0.00427	5185V	5183V	5184V	5187V	5182V	5189V	5186V	5181V	5188V	5180V	5183I	5187I	5182I	5189I	5186I	5181I	5188I	5180I
Cu-100	0.00427	5285V	5283V	5284V	5287V	5282V	5289V	5286V	5281V	5288V	5280V	5283I	5287I	5282I	5289I	5286I	5281I	5288I	5280I
Ni-100	0.00618	5385V	5383V	5384V	5387V	5382V	5389V	5386V	5381V	5388V	5380V	5383I	5387I	5382I	5389I	5386I	5381I	5388I	5380I
Ni-120	0.00672	5485V	5483V	5484V	5487V	5482V	5489V	5486V	5481V	5488V	5480V	5483I	5487I	5482I	5489I	5486I	5481I	5488I	5480I
Ni-Fe-500	0.00518	5585V	5583V	5584V	5587V	5582V	5589V	5586V	5581V	5588V	5580V	5583I	5587I	5582I	5589I	5586I	5581I	5588I	5580I
Ni-Fe-1000	0.00527	5685V	5683V	5684V	5687V	5682V	5689V	5686V	5681V	5688V	5680V	5683I	5687I	5682I	5689I	5686I	5681I	5688I	5680I
Ni-Fe-2000	0.00527	5785V	5783V	5784V	5787V	5782V	5789V	5786V	5781V	5788V	5780V	5783I	5787I	5782I	5789I	5786I	5781I	5788I	5780I
Pt-10	0.00385	58A5V	58A3V	58A4V	58A7V	58A2V	58A9V	58A6V	58A1V	58A8V	58A0V	58A3I	58A7I	58A2I	58A9I	58A6I	58A1I	58A8I	58A0I
Pt-10	0.003911	58B5V	58B3V	58B4V	58B7V	58B2V	58B9V	58B6V	58B1V	58B8V	58B0V	58B3I	58B7I	58B2I	58B9I	58B6I	58B1I	58B8I	58B0I
Pt-10	0.003916	58C5V	58C3V	58C4V	58C7V	58C2V	58C9V	58C6V	58C1V	58C8V	58C0V	58C3I	58C7I	58C2I	58C9I	58C6I	58C1I	58C8I	58C0I
Pt-10	0.003926	58D5V	58D3V	58D4V	58D7V	58D2V	58D9V	58D6V	58D1V	58D8V	58D0V	58D3I	58D7I	58D2I	58D9I	58D6I	58D1I	58D8I	58D0I
Pt-25	0.003926	59D5V	59D3V	59D4V	59D7V	59D2V	59D9V	59D6V	59D1V	59D8V	59D0V	59D3I	59D7I	59D2I	59D9I	59D6I	59D1I	59D8I	59D0I
Pt-50	0.00385	5AA5V	5AA3V	5AA4V	5AA7V	5AA2V	5AA9V	5AA6V	5AA1V	5AA8V	5AA0V	5AA3I	5AA7I	5AA2I	5AA9I	5AA6I	5AA1I	5AA8I	5AA0I
Pt-50	0.003911	5AB5V	5AB3V	5AB4V	5AB7V	5AB2V	5AB9V	5AB6V	5AB1V	5AB8V	5AB0V	5AB3I	5AB7I	5AB2I	5AB9I	5AB6I	5AB1I	5AB8I	5AB0I
Pt-50	0.003916	5AC5V	5AC3V	5AC4V	5AC7V	5AC2V	5AC9V	5AC6V	5AC1V	5AC8V	5AC0V	5AC3I	5AC7I	5AC2I	5AC9I	5AC6I	5AC1I	5AC8I	5AC0I
Pt-50	0.003926	5AD5V	5AD3V	5AD4V	5AD7V	5AD2V	5AD9V	5AD6V	5AD1V	5AD8V	5AD0V	5AD3I	5AD7I	5AD2I	5AD9I	5AD6I	5AD1I	5AD8I	5AD0I
Pt-100	0.00385	5BA5V	5BA3V	5BA4V	5BA7V	5BA2V	5BA9V	5BA6V	5BA1V	5BA8V	5BA0V	5BA3I	5BA7I	5BA2I	5BA9I	5BA6I	5BA1I	5BA8I	5BA0I
Pt-100	0.003911	5BB5V	5BB3V	5BB4V	5BB7V	5BB2V	5BB9V	5BB6V	5BB1V	5BB8V	5BB0V	5BB3I	5BB7I	5BB2I	5BB9I	5BB6I	5BB1I	5BB8I	5BB0I
Pt-100	0.003916	5BC5V	5BC3V	5BC4V	5BC7V	5BC2V	5BC9V	5BC6V	5BC1V	5BC8V	5BC0V	5BC3I	5BC7I	5BC2I	5BC9I	5BC6I	5BC1I	5BC8I	5BC0I
Pt-100	0.003926	5BD5V	5BD3V	5BD4V	5BD7V	5BD2V	5BD9V	5BD6V	5BD1V	5BD8V	5BD0V	5BD3I	5BD7I	5BD2I	5BD9I	5BD6I	5BD1I	5BD8I	5BD0I
Pt-200	0.00385	5CA5V	5CA3V	5CA4V	5CA7V	5CA2V	5CA9V	5CA6V	5CA1V	5CA8V	5CA0V	5CA3I	5CA7I	5CA2I	5CA9I	5CA6I	5CA1I	5CA8I	5CA0I
Pt-200	0.003911	5CB5V	5CB3V	5CB4V	5CB7V	5CB2V	5CB9V	5CB6V	5CB1V	5CB8V	5CB0V	5CB3I	5CB7I	5CB2I	5CB9I	5CB6I	5CB1I	5CB8I	5CB0I
Pt-200	0.003916	5CC5V	5CC3V	5CC4V	5CC7V	5CC2V	5CC9V	5CC6V	5CC1V	5CC8V	5CC0V	5CC3I	5CC7I	5CC2I	5CC9I	5CC6I	5CC1I	5CC8I	5CC0I
Pt-200	0.003926	5CD5V	5CD3V	5CD4V	5CD7V	5CD2V	5CD9V	5CD6V	5CD1V	5CD8V	5CD0V	5CD3I	5CD7I	5CD2I	5CD9I	5CD6I	5CD1I	5CD8I	5CD0I
Pt-470	0.003926	5DD5V	5DD3V	5DD4V	5DD7V	5DD2V	5DD9V	5DD6V	5DD1V	5DD8V	5DD0V	5DD3I	5DD7I	5DD2I	5DD9I	5DD6I	5DD1I	5DD8I	5DD0I
Pt-500	0.00385	5EA5V	5EA3V	5EA4V	5EA7V	5EA2V	5EA9V	5EA6V	5EA1V	5EA8V	5EA0V	5EA3I	5EA7I	5EA2I	5EA9I	5EA6I	5EA1I	5EA8I	5EA0I
Pt-500	0.003911	5EB5V	5EB3V	5EB4V	5EB7V	5EB2V	5EB9V	5EB6V	5EB1V	5EB8V	5EB0V	5EB3I	5EB7I	5EB2I	5EB9I	5EB6I	5EB1I	5EB8I	5EB0I
Pt-500	0.003916	5EC5V	5EC3V	5EC4V	5EC7V	5EC2V	5EC9V	5EC6V	5EC1V	5EC8V	5EC0V	5EC3I	5EC7I	5EC2I	5EC9I	5EC6I	5EC1I	5EC8I	5EC0I
Pt-500	0.003926	5ED5V	5ED3V	5ED4V	5ED7V	5ED2V	5ED9V	5ED6V	5ED1V	5ED8V	5ED0V	5ED3I	5ED7I	5ED2I	5ED9I	5ED6I	5ED1I	5ED8I	5ED0I
Pt-1000	0.00375	5F95V	5F93V	5F94V	5F97V	5F92V	5F99V	5F96V	5F91V	5F98V	5F90V	5F93I	5F97I	5F92I	5F99I	5F96I	5F91I	5F98I	5F90I
Pt-1000	0.00385	5FA5V	5FA3V	5FA4V	5FA7V	5FA2V	5FA9V	5FA6V	5FA1V	5FA8V	5FA0V	5FA3I	5FA7I	5FA2I	5FA9I	5FA6I	5FA1I	5FA8I	5FA0I
Pt-1000	0.003911	5FB5V	5FB3V	5FB4V	5FB7V	5FB2V	5FB9V	5FB6V	5FB1V	5FB8V	5FB0V	5FB3I	5FB7I	5FB2I	5FB9I	5FB6I	5FB1I	5FB8I	5FB0I
Pt-1000	0.003916	5FC5V	5FC3V	5FC4V	5FC7V	5FC2V	5FC9V	5FC6V	5FC1V	5FC8V	5FC0V	5FC3I	5FC7I	5FC2I	5FC9I	5FC6I	5FC1I	5FC8I	5FC0I
Pt-1000	0.003926	5FD5V	5FD3V	5FD4V	5FD7V	5FD2V	5FD9V	5FD6V	5FD1V	5FD8V	5FD0V	5FD3I	5FD7I	5FD2I	5FD9I	5FD6I	5FD1I	5FD8I	5FD0I

Range Table: Potentiometer

For models with "R" option, output ranges are reversed

Potentiometer up to 1 MΩ	Output Switches	±10 V	0-10 V	±5 V	2-10 V	0-8 V	0-5 V	1-5 V	0-4 V	0-2 V	0-1 V	0-20 mA	4-20 mA	0-16 mA	0-10 mA	2-10 mA	0-8 mA	0-4 mA	0-2 mA
		Smallest	ABCDE	ABCDE	ABCDE	ABCDE	ABCDE	ABCDE	ABCDE	ABCDE	ABCDE	ABCDE	ABCDE	ABCDE	ABCDE	ABCDE	ABCDE	ABCDE	ABCDE
4 V	1 kΩ	1405V	1403V	1404V	1407V	1402V	1409V	1406V	1401V	1408V	1400V	1403I	1407I	1402I	1409I	1406I	1401I	1408I	1400I
2 V	500 Ω	1205V	1203V	1204V	1207V	1202V	1209V	1206V	1201V	1208V	1200V	1203I	1207I	1202I	1209I	1206I	1201I	1208I	1200I
1 V	100 Ω	1105V	1103V	1104V	1107V	1102V	1109V	1106V	1101V	1108V	1100V	1103I	1107I	1102I	1109I	1106I	1101I	1108I	1100I

Range Table: DC Voltage, DC Current

For models with "R" option, output ranges are reversed

DC	Output	±10 V	0-10 V	±5 V	2-10 V	0-8 V	0-5 V	1-5 V	0-4 V	0-2 V	0-1 V	0-20 mA	4-20 mA	0-16 mA	0-10 mA	2-10 mA	0-8 mA	0-4 mA	0-2 mA	
	Switches	ABCDE	ABCDE	ABCDE	ABCDE	ABCDE	ABCDE	ABCDE	ABCDE	ABCDE	ABCDE	ABCDE	ABCDE	ABCDE	ABCDE	ABCDE	ABCDE	ABCDE	ABCDE	ABCDE
Type	Range	ABCDE	ABCDE	ABCDE	ABCDE	ABCDE	ABCDE	ABCDE	ABCDE	ABCDE	ABCDE	ABCDE	ABCDE	ABCDE	ABCDE	ABCDE	ABCDE	ABCDE	ABCDE	ABCDE
±mV	±25 mV	9B35V	9B33V	9B34V	9B37V	9B32V	9B39V	9B36V	9B31V	9B38V	9B30V	9B33I	9B37I	9B32I	9B39I	9B36I	9B31I	9B38I	9B30I	
±mV	±100 mV	9145V	9143V	9144V	9147V	9142V	9149V	9146V	9141V	9148V	9140V	9143I	9147I	9142I	9149I	9146I	9141I	9148I	9140I	
±mV	±50 mV	9D35V	9D33V	9D34V	9D37V	9D32V	9D39V	9D36V	9D31V	9D38V	9D30V	9D33I	9D37I	9D32I	9D39I	9D36I	9D31I	9D38I	9D30I	
±V	±125 V	9345V	9343V	9344V	9347V	9342V	9349V	9346V	9341V	9348V	9340V	9343I	9347I	9342I	9349I	9346I	9341I	9348I	9340I	
±V	±0.2 V	9545V	9543V	9544V	9547V	9542V	9549V	9546V	9541V	9548V	9540V	9543I	9547I	9542I	9549I	9546I	9541I	9548I	9540I	
±V	±0.25 V	9845V	9843V	9844V	9847V	9842V	9849V	9846V	9841V	9848V	9840V	9843I	9847I	9842I	9849I	9846I	9841I	9848I	9840I	
±V	±0.5 V	9D45V	9D43V	9D44V	9D47V	9D42V	9D49V	9D46V	9D41V	9D48V	9D40V	9D43I	9D47I	9D42I	9D49I	9D46I	9D41I	9D48I	9D40I	
±V	±0.8 V	9155V	9153V	9154V	9157V	9152V	9159V	9156V	9151V	9158V	9150V	9153I	9157I	9152I	9159I	9156I	9151I	9158I	9150I	
±V	±1 V	9165V	9163V	9164V	9167V	9162V	9169V	9166V	9161V	9168V	9160V	9163I	9167I	9162I	9169I	9166I	9161I	9168I	9160I	
±V	±1.25 V	9365V	9363V	9364V	9367V	9362V	9369V	9366V	9361V	9368V	9360V	9363I	9367I	9362I	9369I	9366I	9361I	9368I	9360I	
±V	±2 V	9565V	9563V	9564V	9567V	9562V	9569V	9566V	9561V	9568V	9560V	9563I	9567I	9562I	9569I	9566I	9561I	9568I	9560I	
±V	±2.5 V	9865V	9863V	9864V	9867V	9862V	9869V	9866V	9861V	9868V	9860V	9863I	9867I	9862I	9869I	9866I	9861I	9868I	9860I	
±V	±4 V	9A65V	9A63V	9A64V	9A67V	9A62V	9A69V	9A66V	9A61V	9A68V	9A60V	9A63I	9A67I	9A62I	9A69I	9A66I	9A61I	9A68I	9A60I	
±V	±5 V	9D65V	9D63V	9D64V	9D67V	9D62V	9D69V	9D66V	9D61V	9D68V	9D60V	9D63I	9D67I	9D62I	9D69I	9D66I	9D61I	9D68I	9D60I	
±V	±8 V	9175V	9173V	9174V	9177V	9172V	9179V	9176V	9171V	9178V	9170V	9173I	9177I	9172I	9179I	9176I	9171I	9178I	9170I	
±V	±10 V	9275V	9273V	9274V	9277V	9272V	9279V	9276V	9271V	9278V	9270V	9273I	9277I	9272I	9279I	9276I	9271I	9278I	9270I	
mV	0-50 mV	9C35V	9C33V	9C34V	9C37V	9C32V	9C39V	9C36V	9C31V	9C38V	9C30V	9C33I	9C37I	9C32I	9C39I	9C36I	9C31I	9C38I	9C30I	
mV	0-100 mV	9E35V	9E33V	9E34V	9E37V	9E32V	9E39V	9E36V	9E31V	9E38V	9E30V	9E33I	9E37I	9E32I	9E39I	9E36I	9E31I	9E38I	9E30I	
V	0.1-0.5 V	9745V	9743V	9744V	9747V	9742V	9749V	9746V	9741V	9748V	9740V	9743I	9747I	9742I	9749I	9746I	9741I	9748I	9740I	
V	0.2-1 V	9C45V	9C43V	9C44V	9C47V	9C42V	9C49V	9C46V	9C41V	9C48V	9C40V	9C43I	9C47I	9C42I	9C49I	9C46I	9C41I	9C48I	9C40I	
V	0-0.2 V	9245V	9243V	9244V	9247V	9242V	9249V	9246V	9241V	9248V	9240V	9243I	9247I	9242I	9249I	9246I	9241I	9248I	9240I	
V	0-0.25 V	9445V	9443V	9444V	9447V	9442V	9449V	9446V	9441V	9448V	9440V	9443I	9447I	9442I	9449I	9446I	9441I	9448I	9440I	
V	0-0.4 V	9645V	9643V	9644V	9647V	9642V	9649V	9646V	9641V	9648V	9640V	9643I	9647I	9642I	9649I	9646I	9641I	9648I	9640I	
V	0-0.5 V	9945V	9943V	9944V	9947V	9942V	9949V	9946V	9941V	9948V	9940V	9943I	9947I	9942I	9949I	9946I	9941I	9948I	9940I	
V	0-0.8 V	9B45V	9B43V	9B44V	9B47V	9B42V	9B49V	9B46V	9B41V	9B48V	9B40V	9B43I	9B47I	9B42I	9B49I	9B46I	9B41I	9B48I	9B40I	
V	0-1 V	9E45V	9E43V	9E44V	9E47V	9E42V	9E49V	9E46V	9E41V	9E48V	9E40V	9E43I	9E47I	9E42I	9E49I	9E46I	9E41I	9E48I	9E40I	
V	0-2 V	9265V	9263V	9264V	9267V	9262V	9269V	9266V	9261V	9268V	9260V	9263I	9267I	9262I	9269I	9266I	9261I	9268I	9260I	
V	0-2.5 V	9465V	9463V	9464V	9467V	9462V	9469V	9466V	9461V	9468V	9460V	9463I	9467I	9462I	9469I	9466I	9461I	9468I	9460I	
V	0-4 V	9665V	9663V	9664V	9667V	9662V	9669V	9666V	9661V	9668V	9660V	9663I	9667I	9662I	9669I	9666I	9661I	9668I	9660I	
V	0-5 V	9965V	9963V	9964V	9967V	9962V	9969V	9966V	9961V	9968V	9960V	9963I	9967I	9962I	9969I	9966I	9961I	9968I	9960I	
V	1-5 V	9765V	9763V	9764V	9767V	9762V	9769V	9766V	9761V	9768V	9760V	9763I	9767I	9762I	9769I	9766I	9761I	9768I	9760I	
V	0-8 V	9B65V	9B63V	9B64V	9B67V	9B62V	9B69V	9B66V	9B61V	9B68V	9B60V	9B63I	9B67I	9B62I	9B69I	9B66I	9B61I	9B68I	9B60I	
V	0-10 V	9E65V	9E63V	9E64V	9E67V	9E62V	9E69V	9E66V	9E61V	9E68V	9E60V	9E63I	9E67I	9E62I	9E69I	9E66I	9E61I	9E68I	9E60I	
V	2-10 V	9C65V	9C63V	9C64V	9C67V	9C62V	9C69V	9C66V	9C61V	9C68V	9C60V	9C63I	9C67I	9C62I	9C69I	9C66I	9C61I	9C68I	9C60I	
µA	±500 µA	ABB5V	ABB3V	ABB4V	ABB7V	ABB2V	ABB9V	ABB6V	ABB1V	ABB8V	ABB0V	ABB3I	ABB7I	ABB2I	ABB9I	ABB6I	ABB1I	ABB8I	ABB0I	
mA	±1 mA	ADB5V	ADB3V	ADB4V	ADB7V	ADB2V	ADB9V	ADB6V	ADB1V	ADB8V	ADB0V	ADB3I	ADB7I	ADB2I	ADB9I	ADB6I	ADB1I	ADB8I	ADB0I	
mA	±2 mA	A1C5V	A1C3V	A1C4V	A1C7V	A1C2V	A1C9V	A1C6V	A1C1V	A1C8V	A1C0V	A1C3I	A1C7I	A1C2I	A1C9I	A1C6I	A1C1I	A1C8I	A1C0I	
mA	±2.5 mA	A3C5V	A3C3V	A3C4V	A3C7V	A3C2V	A3C9V	A3C6V	A3C1V	A3C8V	A3C0V	A3C3I	A3C7I	A3C2I	A3C9I	A3C6I	A3C1I	A3C8I	A3C0I	
mA	±4 mA	A5C5V	A5C3V	A5C4V	A5C7V	A5C2V	A5C9V	A5C6V	A5C1V	A5C8V	A5C0V	A5C3I	A5C7I	A5C2I	A5C9I	A5C6I	A5C1I	A5C8I	A5C0I	
mA	±5 mA	A8C5V	A8C3V	A8C4V	A8C7V	A8C2V	A8C9V	A8C6V	A8C1V	A8C8V	A8C0V	A8C3I	A8C7I	A8C2I	A8C9I	A8C6I	A8C1I	A8C8I	A8C0I	
mA	±8 mA	AAC5V	AAC3V	AAC4V	AAC7V	AAC2V	AAC9V	AAC6V	AAC1V	AAC8V	AAC0V	AAC3I	AAC7I	AAC2I	AAC9I	AAC6I	AAC1I	AAC8I	AAC0I	
mA	±10 mA	ADC5V	ADC3V	ADC4V	ADC7V	ADC2V	ADC9V	ADC6V	ADC1V	ADC8V	ADC0V	ADC3I	ADC7I	ADC2I	ADC9I	ADC6I	ADC1I	ADC8I	ADC0I	
mA	±16 mA	A1D5V	A1D3V	A1D4V	A1D7V	A1D2V	A1D9V	A1D6V	A1D1V	A1D8V	A1D0V	A1D3I	A1D7I	A1D2I	A1D9I	A1D6I	A1D1I	A1D8I	A1D0I	
mA	±20 mA	A2D5V	A2D3V	A2D4V	A2D7V	A2D2V	A2D9V	A2D6V	A2D1V	A2D8V	A2D0V	A2D3I	A2D7I	A2D2I	A2D9I	A2D6I	A2D1I	A2D8I	A2D0I	
mA	0-1 mA	ACB5V	ACB3V	ACB4V	ACB7V	ACB2V	ACB9V	ACB6V	ACB1V	ACB8V	ACB0V	ACB3I	ACB7I	ACB2I	ACB9I	ACB6I	ACB1I	ACB8I	ACB0I	
mA	0-2 mA	AEB5V	AEB3V	AEB4V	AEB7V	AEB2V	AEB9V	AEB6V	AEB1V	AEB8V	AEB0V	AEB3I	AEB7I	AEB2I	AEB9I	AEB6I	AEB1I	AEB8I	AEB0I	
mA	0-4 mA	A2C5V	A2C3V	A2C4V	A2C7V	A2C2V	A2C9V	A2C6V	A2C1V	A2C8V	A2C0V	A2C3I	A2C7I	A2C2I	A2C9I	A2C6I	A2C1I	A2C8I	A2C0I	
mA	0-5 mA	A4C5V	A4C3V	A4C4V	A4C7V	A4C2V	A4C9V	A4C6V	A4C1V	A4C8V	A4C0V	A4C3I	A4C7I	A4C2I	A4C9I	A4C6I	A4C1I	A4C8I	A4C0I	
mA	0-8 mA	A6C5V	A6C3V	A6C4V	A6C7V	A6C2V	A6C9V	A6C6V	A6C1V	A6C8V	A6C0V	A6C3I	A6C7I	A6C2I	A6C9I	A6C6I	A6C1I	A6C8I	A6C0I	
mA	0-10 mA	A9C5V	A9C3V	A9C4V	A9C7V	A9C2V	A9C9V	A9C6V	A9C1V	A9C8V	A9C0V	A9C3I	A9C7I	A9C2I	A9C9I	A9C6I	A9C1I	A9C8I	A9C0I	
mA	2-10 mA	A7C5V	A7C3V	A7C4V	A7C7V	A7C2V	A7C9V	A7C6V	A7C1V	A7C8V	A7C0V	A7C3I	A7C7I	A7C2I	A7C9I	A7C6I	A7C1I	A7C8I	A7C0I	
mA	0-16 mA	ABC5V	ABC3V	ABC4V	ABC7V	ABC2V	ABC9V	ABC6V	ABC1V	ABC8V	ABC0V	ABC3I	ABC7I	ABC2I	ABC9I	ABC6I	ABC1I	ABC8I	ABC0I	
mA	0-20 mA	AEC5V	AEC3V	AEC4V	AEC7V	AEC2V	AEC9V	AEC6V	AEC1V	AEC8V	AEC0V	AEC3I	AEC7I	AEC2I	AEC9I	AEC6I	AEC1I	AEC8I	AEC0I	
mA	4-20 mA	ACC5V	ACC3V	ACC4V	ACC7V	ACC2V	ACC9V	ACC6V	ACC1V	ACC8V	ACC0V	ACC3I	ACC7I	ACC2I	ACC9I	ACC6I	ACC1I	ACC8I	ACC0I	

Range Table: Custom Input Range

For models with "R" option, output ranges are reversed

Custom Input	Output	±10 V	0-10 V	±5 V	2-10 V	0-8 V	0-5 V	1-5 V	0-4 V	0-2 V	0-1 V	0-20 mA	4-20 mA	0-16 mA	0-10 mA	2-10 mA	0-8 mA	0-4 mA	0-2 mA	
	Switches	ABCDE	ABCDE	ABCDE	ABCDE	ABCDE	ABCDE	ABCDE	ABCDE	ABCDE	ABCDE	ABCDE	ABCDE	ABCDE	ABCDE	ABCDE	ABCDE	ABCDE	ABCDE	ABCDE
Type		ABCDE	ABCDE	ABCDE	ABCDE	ABCDE	ABCDE	ABCDE	ABCDE	ABCDE	ABCDE	ABCDE	ABCDE	ABCDE	ABCDE	ABCDE	ABCDE	ABCDE	ABCDE	ABCDE
See module side label		FF85V	FF83V	FF84V	FF87V	FF82V	FF89V	FF86V	FF81V	FF88V	FF80V	FF83I	FF87I	FF82I	FF89I	FF86I	FF81I	FF88I	FF80I	

Model	Power	Options—add to end of model number	Optional NIST Tracability—Choose One
<input type="checkbox"/> APD 8000	85-265 VAC, 50/60 Hz or 60-300 VDC	<input type="checkbox"/> R Reverse acting output	<input type="checkbox"/> NC5 5 point NIST traceable calibration certificate
<input type="checkbox"/> APD 8000 D	9-30 VDC or 10-32 VAC	<input type="checkbox"/> U Conformal coating for moisture resistance	<input type="checkbox"/> NC11 11 point NIST traceable calibration certificate

Factory Default Settings—Choose One Input Type and One Output Type

We can set up the I/O ranges at no extra charge. Please provide the exact sensor type, input range, and output range on your order or use this handy sheet. Models are field rangeable. If I/O is not specified, default settings are type J thermocouple, 0-500°C, 4-20 mA output.

DC Input				RTD Input	RTD Wires		Output
<input type="checkbox"/> ±25 mV	<input type="checkbox"/> 0-2.5 V	<input type="checkbox"/> 0-4 V	<input type="checkbox"/> ±16 mA	<input type="checkbox"/> Cu-10, 0.00427	<input type="checkbox"/> 2 wire		<input type="checkbox"/> ±10 V
<input type="checkbox"/> ±100 mV	<input type="checkbox"/> ±8 V	<input type="checkbox"/> 0-5 V	<input type="checkbox"/> ±20 mA	<input type="checkbox"/> Cu-100, 0.00427	<input type="checkbox"/> 3 wire		<input type="checkbox"/> 0-10 V
<input type="checkbox"/> ±50 mV	<input type="checkbox"/> ±10 V	<input type="checkbox"/> 1-5 V	<input type="checkbox"/> 0-1 mA	<input type="checkbox"/> Ni-100, 0.00618	<input type="checkbox"/> 4 wire		<input type="checkbox"/> ±5 V
<input type="checkbox"/> ±.125 V	<input type="checkbox"/> 0-50 mV	<input type="checkbox"/> 0-8 V	<input type="checkbox"/> 0-2 mA	<input type="checkbox"/> Ni-120, 0.00672	<input type="checkbox"/> 4 with current rotation		<input type="checkbox"/> 2-10 V
<input type="checkbox"/> ±0.2 V	<input type="checkbox"/> 0-100 mV	<input type="checkbox"/> 0-10 V	<input type="checkbox"/> 0-4 mA	<input type="checkbox"/> Ni-Fe-500, 0.00518	Low Value °F/°C	High Value °F/°C	<input type="checkbox"/> 0-8 V
<input type="checkbox"/> ±0.25 V	<input type="checkbox"/> 0.1-0.5 V	<input type="checkbox"/> 2-10 V	<input type="checkbox"/> 0-5 mA	<input type="checkbox"/> Ni-Fe-1000, 0.00527			<input type="checkbox"/> 0-5 V
<input type="checkbox"/> ±0.5 V	<input type="checkbox"/> 0.2-1 V	<input type="checkbox"/> ±500 µA	<input type="checkbox"/> 0-8 mA	<input type="checkbox"/> Ni-Fe-2000, 0.00527			<input type="checkbox"/> 1-5 V
<input type="checkbox"/> ±0.8 V	<input type="checkbox"/> 0-0.2 V	<input type="checkbox"/> ±1 mA	<input type="checkbox"/> 0-10 mA	<input type="checkbox"/> Pt-10, 0.00385			<input type="checkbox"/> 0-4 V
<input type="checkbox"/> ±1 V	<input type="checkbox"/> 0-0.25 V	<input type="checkbox"/> ±2 mA	<input type="checkbox"/> 2-10 mA	<input type="checkbox"/> Pt-10, 0.003911			<input type="checkbox"/> 0-2 V
<input type="checkbox"/> ±1.25 V	<input type="checkbox"/> 0-0.4 V	<input type="checkbox"/> ±2.5 mA	<input type="checkbox"/> 0-16 mA	<input type="checkbox"/> Pt-10, 0.003916			<input type="checkbox"/> 0-1 V
<input type="checkbox"/> ±2 V	<input type="checkbox"/> 0-0.5 V	<input type="checkbox"/> ±4 mA	<input type="checkbox"/> 0-20 mA	<input type="checkbox"/> Pt-10, 0.003926			<input type="checkbox"/> 0-20 mA
<input type="checkbox"/> ±2.5 V	<input type="checkbox"/> 0-0.8 V	<input type="checkbox"/> ±5 mA	<input type="checkbox"/> 4-20 mA	<input type="checkbox"/> Pt-25, 0.003926			<input type="checkbox"/> 4-20 mA
<input type="checkbox"/> ±4 V	<input type="checkbox"/> 0-1 V	<input type="checkbox"/> ±8 mA		<input type="checkbox"/> Pt-50, 0.00385			<input type="checkbox"/> 0-16 mA
<input type="checkbox"/> ±5 V	<input type="checkbox"/> 0-2 V	<input type="checkbox"/> ±10 mA		<input type="checkbox"/> Pt-50, 0.003911			<input type="checkbox"/> 0-10 mA
Thermocouple Input	T/C Burnout	Low Value °F/°C	High Value °F/°C	<input type="checkbox"/> Pt-50, 0.003916			<input type="checkbox"/> 2-10 mA
<input type="checkbox"/> J	<input type="checkbox"/> Upscale			<input type="checkbox"/> Pt-50, 0.003926			<input type="checkbox"/> 0-8 mA
<input type="checkbox"/> K	<input type="checkbox"/> Downscale			<input type="checkbox"/> Pt-100, 0.00385			<input type="checkbox"/> 0-4 mA
<input type="checkbox"/> T	<input type="checkbox"/> Last valid output			<input type="checkbox"/> Pt-100, 0.003911			<input type="checkbox"/> 0-2 mA
<input type="checkbox"/> E	T/C Setting			<input type="checkbox"/> Pt-100, 0.003916			Custom Output
<input type="checkbox"/> R	<input type="checkbox"/> Single-ended setting for grounded or ungrounded thermocouples			<input type="checkbox"/> Pt-100, 0.003926			Low Value, Units
<input type="checkbox"/> S	<input type="checkbox"/> Differential setting for ungrounded thermocouples or thermocouples operating in the negative mV range (typically below 0°C)			<input type="checkbox"/> Pt-200, 0.00385			
<input type="checkbox"/> N				<input type="checkbox"/> Pt-200, 0.003911			
<input type="checkbox"/> B				<input type="checkbox"/> Pt-200, 0.003916			High Value, Units
<input type="checkbox"/> C				<input type="checkbox"/> Pt-200, 0.003926			
<input type="checkbox"/> D				<input type="checkbox"/> Pt-470, 0.003926			
<input type="checkbox"/> G				<input type="checkbox"/> Pt-500, 0.00385			
<input type="checkbox"/> M				<input type="checkbox"/> Pt-500, 0.003911			
<input type="checkbox"/> P				<input type="checkbox"/> Pt-500, 0.003916			
Thermistor Input	Resistance	Low Value °F/°C	High Value °F/°C	<input type="checkbox"/> Pt-500, 0.003926			
<input type="checkbox"/> 44004/44033	2.252 kΩ			<input type="checkbox"/> Pt-1000, 0.00375			
<input type="checkbox"/> 44005/44030	3 kΩ			<input type="checkbox"/> Pt-1000, 0.00385			
<input type="checkbox"/> 44007/44034	5 kΩ			<input type="checkbox"/> Pt-1000, 0.003911			
<input type="checkbox"/> 44006/44031	10 kΩ			<input type="checkbox"/> Pt-1000, 0.003916			
<input type="checkbox"/> 44008/44032	30 kΩ			<input type="checkbox"/> Pt-1000, 0.003926			
<input type="checkbox"/> YSI 400	2.252 kΩ						
<input type="checkbox"/> Spectrum 1003	1 kΩ						
3-Wire Potentiometer Input, 1 MΩ max.				Custom Input—provide curve data if non-linear			
Excitation	Min. Span	Low Value Ω	High Value Ω	Sensor Type		Low Value, Units	High Value, Units
<input type="checkbox"/> 4 V	1 kΩ						
<input type="checkbox"/> 2 V	500 Ω						
<input type="checkbox"/> 1 V	100 Ω						

Ordering Example

APD 8000 D U NC11, Input: Pt-100, 0.00385, 3 wire, Output: 4-20 mA

APD 8000, low voltage powered, conformal coated circuit boards, 11 point NIST, input: 100 Ohm RTD, 385 curve, 3 wire, output: 4-20 mA output

Date installed	Model	Serial number	Sensor type	Sensor range	Sensor burnout setting	Output range	A	B	C	D	E