

AC to DC Transmitters, Isolated

API 6010 G, API 6010 G 5A 

Input: 0-50 mVAC to 0-300 VAC, 0-1 mAAC to 0-5 AAC
Output: 0-1 V to 0-10 VDC, ± 5 VDC, ± 10 VDC, 0-1 mA to 0-20 mADC, 4-20 mADC

- Precision Internal AC/DC Converter
- Input and Output LoopTracker® LEDs
- Full 2000 V Input/Output/Power Isolation
- Functional Test Button

Applications

- Convert an AC Signal to a DC Process Signal
- Monitor Voltage Ranges
- Convert, Amplify Low Level AC Signals

AC Input Range

Factory configured, please specify input range
 Consult factory for special ranges

API 6010 G voltage: 0-50 mVAC to 0-300 VAC
 API 6010 G current: 0-1 mAAC to 0-900 mAAC
 API 6010 G 5A current: 0-900 mAAC to 0-5 AAC
 Includes socket with 0.1 Ω , 1%, 25 W shunt resistor

System voltages must not exceed socket voltage rating

Input Impedance (Voltage Input)

API 6010 G: 220 k Ω minimum
 API 6010 G 5A: 0.1 Ω minimum external shunt

Input Voltage Burden (Current Input)

1.0 VRMS maximum

Input Frequency

40 Hz to 1000 Hz sinusoidal

Input Protection, Common Mode

750 VDC or 750 VACp

LoopTracker

Variable brightness LEDs indicate I/O loop level and status

DC Output Range

Factory configured, please specify output range

Voltage: 0-1 VDC to 0-10 VDC
 Bipolar voltage: ± 1 VDC to ± 10 VDC
 Current: 0-2 mADC to 0-20 mADC
 20 V compliance, 1000 Ω at 20 mA

Output Calibration

Multi-turn zero and span potentiometers
 $\pm 15\%$ of adjustment range typical

Output Loop Power Supply

20 VDC nominal, regulated, 25 mADC, max. ripple <10 mVRMS
 Order EXTSUP for an unpowered mA output

Output Test

Button sets output to test level when pressed
 Factory set to approximately 50% of span
 Specify if other output test setting is required

Output Ripple and Noise

Less than 10 mVRMS

Linearity

Better than $\pm 0.1\%$ of span

Ambient Temperature Range and Stability

-10°C to +60°C operating ambient
 Better than $\pm 0.02\%$ of span per °C stability

Response Time

150 milliseconds typical

Isolation

2000 VRMS minimum
 Full isolation: power to input, power to output, input to output

Installation Environment

IP 40, requires installation in panel or enclosure
 6010 G: Use API 008 or API 008 FS socket
 6010 G 5A: Includes API 008 socket with shunt resistor
 Socket mounts to 35 mm DIN rail or can be surface mounted
 UL 508C pollution degree 2 environments or better

Power

Standard: 115 VAC $\pm 10\%$, 50/60 Hz, 2.5 W max.
 A230 option: 230 VAC $\pm 10\%$, 50/60 Hz, 2.5 W max.
 P option: 85-265 VAC 50/60 Hz, 60-300 VDC 2.5 W typ.
 D option: 9-30 VDC, 2.5 W typical

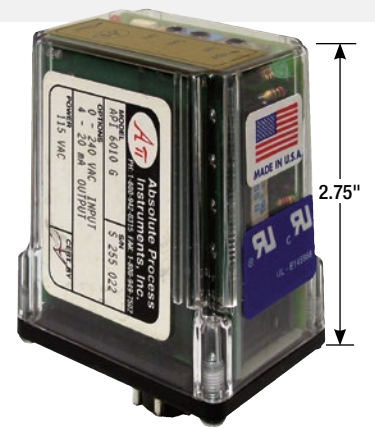
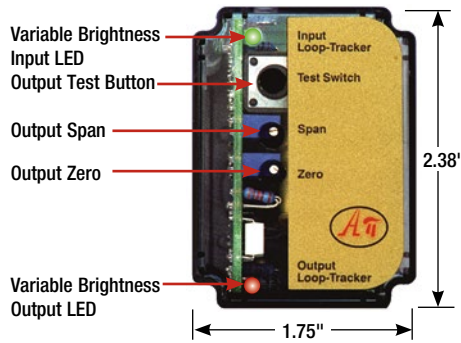

115 VAC, 230 VAC models
 with input up to 150 VAC
 without 5A option

Free Factory I/O Setup!



Quick Link
api-usa.com/6010

Hot Swappable
 Plug-In Design



API 6010 G 5A
 Includes Socket
 & Shunt

Description

The API 6010 G accepts an AC voltage or current input and provides an optically isolated DC voltage or current output that is linearly related to the input. Typical applications include monitoring line, power supply, shunt, and motor voltages or current (either directly or with a current transducer) for control, preventive maintenance, etc.

The API 6010 G 5A is used to measure AC current up to 5 amps by measuring the voltage drop across a 0.1 Ω shunt. Typical applications include monitoring motor current.

The full 3-way (input, output, power) isolation makes this module useful for ground loop elimination or noise pickup reduction. The API 6010 G is factory configured to customer requirements. Consult the factory for assistance with special ranges.

LoopTracker

API exclusive features include two LoopTracker LEDs (green for input, red for output) that vary in intensity with changes in the process input and output signals. These provide a quick visual picture of your process loop at all times and can greatly aid in saving time during initial startup and/or troubleshooting.

Functional Test

An API exclusive feature includes the Functional Test Button to provide a fixed output (independent of the input) when held depressed. The test output level is factory set to 50% of output span. The functional test button greatly aids in saving time during initial startup and/or troubleshooting.

Model	Input	Output	Power
API 6010 G	Factory configured specify mVAC, VAC, or mAAC input range	Factory configured specify VDC or mADC output range	115 VAC
API 6010 G A230			230 VAC
API 6010 G P			85-265 VAC or 60-300 VDC
API 6010 G D	Factory configured specify AC amp input range. Module includes socket and shunt.	Factory configured specify VDC or mADC output range	9-30 VDC
API 6010 G 5A			115 VAC
API 6010 G A230 5A			230 VAC
API 6010 G P 5A			85-265 VAC or 60-300 VDC
API 6010 G D 5A			9-30 VDC

Options—add to end of model number

- EXTSUP** Open collector output when a "sinking" output is required for an external loop supply
- R** Input/output reversal
- U** Conformal coating for moisture resistance

Accessories—order as separate line item for API 6010 G

- API 008** 8-pin socket
- API 008 FS** 8-pin finger-safe socket
- API CLP1** Module hold-down spring for high vibration or mobile applications



API 008 FS
 300 V Rating



API 008
 600 V Rating



API CLP1

Precautions

WARNING! All wiring must be performed by a qualified electrician or instrumentation engineer. See diagram for terminal designations and wiring examples. Consult factory for assistance.

WARNING! Avoid shock hazards! Turn signal input, output, and power off before connecting or disconnecting wiring, or removing or installing module.

Précautions

ATTENTION! Tout le câblage doit être effectué par un électricien ou ingénieur en instrumentation qualifié. Voir le diagramme pour désignations des bornes et des exemples de câblage. Consulter l'usine pour assistance.

ATTENTION! Éviter les risques de choc! Fermez le signal d'entrée, le signal de sortie et l'alimentation électrique avant de connecter ou de déconnecter le câblage, ou de retirer ou d'installer le module.

API maintains a constant effort to upgrade and improve its products. Specifications are subject to change without notice. See api-usa.com for latest product information. Consult factory for your specific requirements.

WARNING: This product can expose you to chemicals including lead and nickel, which are known to the State of California to cause cancer or birth defects or other reproductive harm. For more information go to www.P65Warnings.ca.gov

Electrical Connections

Polarity must be observed for output wiring connections. If the output does not function, check wiring and polarity.

Each product is factory configured to your exact input and output ranges as indicated on the serial number label.

Socket and Mounting

The module installation requires a protective panel or enclosure. Use API 008 or finger-safe API 008 FS socket.

The socket clips to a standard 35 mm DIN rail or can be attached to a flat surface using the two mounting holes.

Signal Input

For safety, input must be off while connecting wiring. The AC signal input is connected to terminals 5 and 6. Input voltages must not exceed socket voltage rating.

The API 6010 G 5A includes a 5 Amp shunt. The module input is set to measure the mV AC drop across the shunt.

Signal Output

Polarity must be observed when connecting the signal output to the load. The positive connection (+) is connected to terminal 7 and the negative (-) is connected to terminal 8.

The module provides 20 VDC power to the output loop (sourcing) when current output is ordered.

A module with the EXTSUP option will have an unpowered (sinking) current output.

Module Power

Check model/serial number label for module operating voltage to make sure it matches available power.

AC power is connected to terminals 1 and 3.

For DC powered modules, polarity MUST be observed.

Positive (+) is wired to terminal 1

Negative (-) is wired to terminal 3

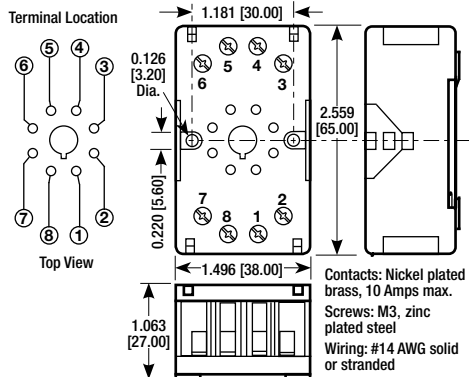
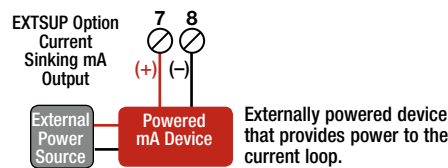
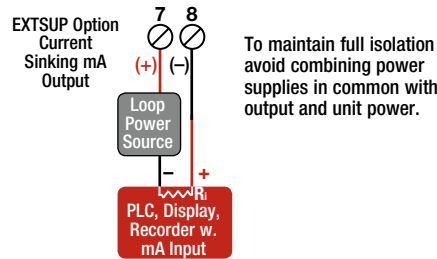
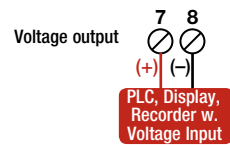
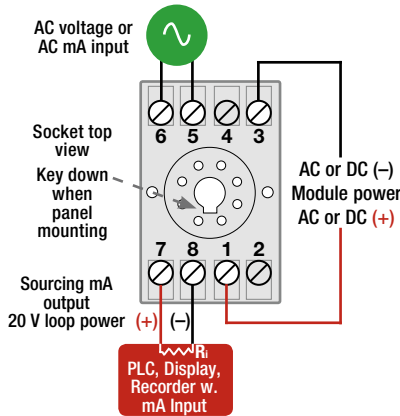
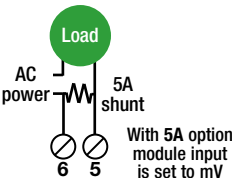
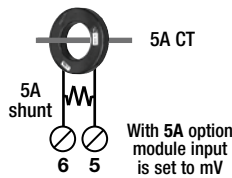

API 008 FS 8-Pin Finger Safe Socket, 300 V Rating

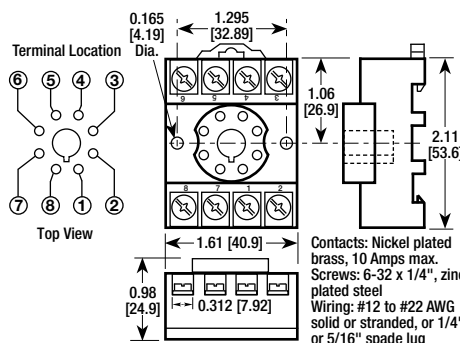

API 008 8-Pin Socket, 600 V Rating

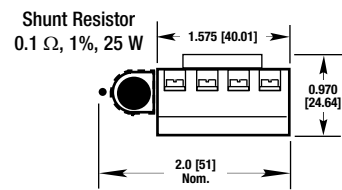
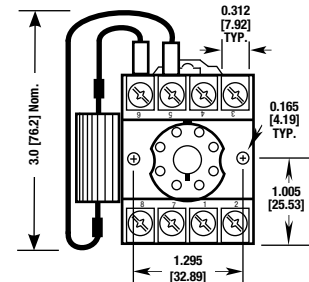

API 6010 G 5A 8-Pin Socket with Shunt, 600 V Rating

Calibration

The Zero and Span potentiometers can be used fine-tune the output range.

1. Power the module and allow a minimum 20 minute warm up time.
2. Using an accurate calibration source, provide an input to the module equal to the minimum input required for the application.
3. Using an accurate measurement device for the output, adjust the Zero potentiometer for the exact minimum output desired. The Zero control should only be adjusted when the input signal is at its minimum. This will produce the corresponding minimum output signal. For example: 4 mA for a 4-20 mA output or -10 V for a ±10V output.
4. Set the input at maximum, and adjust the Span pot for the exact maximum output desired. The Span pot should only be adjusted when the input signal is at its maximum. This will produce the corresponding maximum output signal.
5. Repeat adjustments for maximum accuracy.

Functional Test Button

The functional test button provides a device on the output side of the loop (a panel meter, chart recorder, etc.) with a known good signal that can be used as a system diagnostic aid during initial start-up or during troubleshooting. It is factory set to 50% of output. When the button is released, the output will return to normal.

Operation

The input is either amplified or attenuated, then filtered and processed by a precision full-wave rectification circuit. The result is passed thru a low pass active filter that provides a DC voltage representing the average value of the input. This DC voltage is passed through an optical isolation circuit to the output stage.

The green LoopTracker® input LED provides a visual indication that a signal is being sensed by the input circuitry of the module. It also indicates the input signal strength by changing in intensity as the process changes from minimum to maximum.

If the LED fails to illuminate, or fails to change in intensity as the process changes, check the module power or signal input wiring. Note that it may be difficult to see the LEDs under bright lighting conditions.

The red LoopTracker output LED provides a visual indication that the output signal is functioning. It becomes brighter as the input and the corresponding output change from minimum to maximum.

For current outputs, the red LED will only light if the output loop current path is complete. For either current or voltage outputs, failure to illuminate or a failure to change in intensity as the process changes may indicate a problem with the module power or signal output wiring.