

DIGITAL INDICATING CONTROLLER

BCx2

INSTRUCTION MANUAL

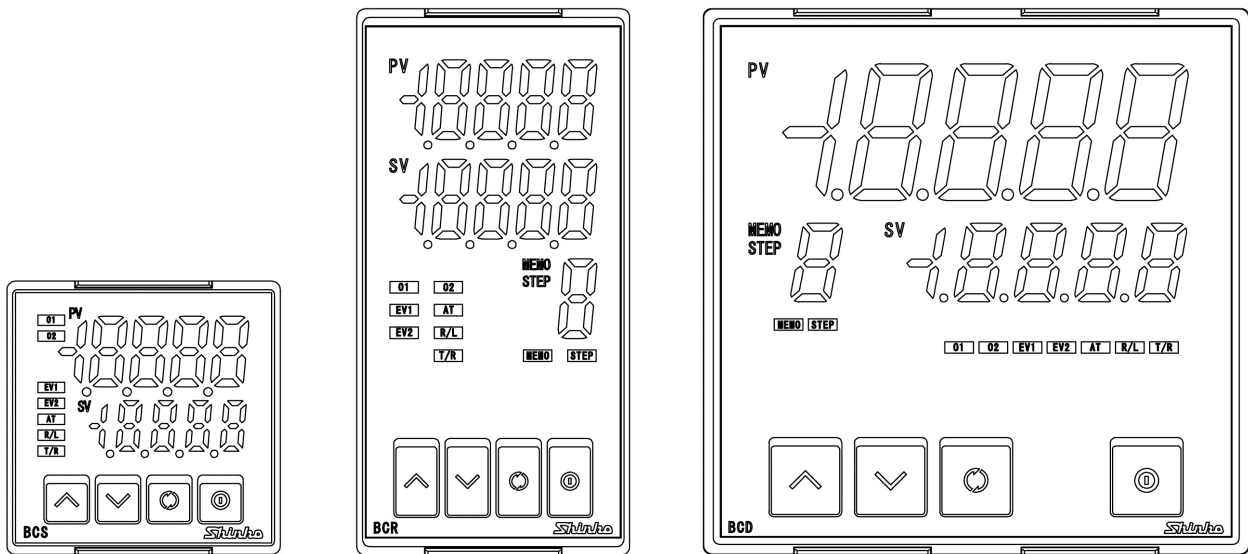

Preface

Thank you for purchasing our digital indicating controller BCx2 (BCS2, BCR2, BCD2). This manual contains instructions for the mounting, functions, operations and notes when operating the BCx2. To prevent accidents arising from the misuse of this controller, please ensure the operator receives this manual.

Abbreviations used in this manual

Abbreviation	Term
PV	Process variable
SV	Desired value
MV	Manipulated variable
DV	Deviation
OUT1	Control output OUT1
OUT2	Control output OUT2
AT	Auto-tuning

Characters used in this manual

Indication	+	0	1	2	3	4	5	6	7	8	9	°C	°F
Number, °C/°F	-1	0	1	2	3	4	5	6	7	8	9	°C	°F
Indication	A	b	c	d	E	F	G	H	I	J	k	L	ñ
Alphabet	A	B	C	D	E	F	G	H	I	J	K	L	M
Indication	n	o	P	q	r	s	T	U	V	w	x	y	z
Alphabet	N	O	P	Q	R	S	T	U	V	W	X	Y	Z

Notes

- This instrument should be used in accordance with the specifications described in the manual. If it is not used according to the specifications, it may malfunction or cause a fire.
- Be sure to follow the warnings, cautions and notices. If they are not observed, serious injury or malfunction may occur.
- The contents of this instruction manual are subject to change without notice.
- Care has been taken to ensure that the contents of this instruction manual are correct, but if there are any doubts, mistakes or questions, please inform our sales department.
- Measures must be taken to ensure that the operator cannot touch power terminals or other high voltage sections.
- Any unauthorized transfer or copying of this document, in part or in whole, is prohibited.
- Shinko Technos Co., Ltd. is not liable for any damage or secondary damage(s) incurred as a result of using this product, including any indirect damage.

Safety Precautions (Be sure to read these precautions before using our products.)

The safety precautions are classified into categories: "Warning" and "Caution". Depending on circumstances, procedures indicated by ⚠ Caution may result in serious consequences, so be sure to follow the directions for usage.

⚠ Warning Procedures which may lead to dangerous conditions and cause death or serious injury, if not carried out properly.

⚠ Caution Procedures which may lead to dangerous conditions and cause superficial to medium injury or physical damage or may degrade or damage the product, if not carried out properly.

⚠ Warning

- To prevent an electrical shock or fire, only Shinko or other qualified service personnel may handle the inner assembly.
- To prevent an electrical shock, fire or damage to the instrument, parts replacement may only be undertaken by Shinko or other qualified service personnel.

⚠ Safety Precautions

- To ensure safe and correct use, thoroughly read and understand this manual before using this instrument.
- This instrument is intended to be used for industrial machinery, machine tools and measuring equipment. Verify correct usage after purpose-of-use consultation with our agency or main office. (Never use this instrument for medical purposes with which human lives are involved.)
- External protection devices such as protective equipment against excessive temperature rise, etc. must be installed, as malfunction of this product could result in serious damage to the system or injury to personnel. Proper periodic maintenance is also required.
- This instrument must be used under the conditions and environment described in this manual. Shinko Technos Co., Ltd. does not accept liability for any injury, loss of life or damage occurring due to the instrument being used under conditions not otherwise stated in this manual.

Caution with respect to Export Trade Control Ordinance

To avoid this instrument from being used as a component in, or as being utilized in the manufacture of weapons of mass destruction (i.e. military applications, military equipment, etc.), please investigate the end users and the final use of this instrument. In the case of resale, ensure that this instrument is not illegally exported.

1. Installation Precautions

⚠ Caution

This instrument is intended to be used under the following environmental conditions (IEC61010-1): Overvoltage category II, Pollution degree 2

Ensure the mounting location corresponds to the following conditions:

- A minimum of dust, and an absence of corrosive gases
- No flammable, explosive gases
- No mechanical vibrations or shocks
- No exposure to direct sunlight, an ambient temperature of -10 to 55°C (14 to 131°F) that does not change rapidly, and no icing
- An ambient non-condensing humidity of 35 to 85%RH
- No large capacity electromagnetic switches or cables through which large current is flowing
- No water, oil or chemicals or where the vapors of these substances can come into direct contact with the unit
- Please note that the ambient temperature of this unit – not the ambient temperature of the control panel – must not exceed 55°C (131°F) if mounted through the face of a control panel, otherwise the life of electronic components (especially electrolytic capacitors) may be shortened.

Note • Avoid setting this instrument directly on or near flammable material even though the case of this instrument is made of flame-resistant resin.

2. Wiring Precautions

Caution

- Do not leave wire remnants in the instrument, as they could cause a fire or malfunction.
- Use the solderless terminal with an insulation sleeve in which the M3 screw fits when wiring the instrument.
- The terminal block of this instrument is designed to be wired from the left side. The lead wire must be inserted from the left side of the terminal, and fastened with the terminal screw.
- Tighten the terminal screw using the specified torque. If excessive force is applied to the screw when tightening, the terminal screw or case may be damaged.
- Do not pull or bend the lead wire on the terminal side when wiring or after wiring, as it could cause malfunction.
- When using a terminal cover for the BCS2, pass terminal wires numbered 7 to 12 into the holes of the terminal cover.
- This instrument does not have a built-in power switch, circuit breaker and fuse.
It is necessary to install a power switch, circuit breaker and fuse near the controller.
(Recommended fuse: Time-lag fuse, rated voltage 250 V AC, rated current 2 A)
- For a 24 V AC/DC power source, do not confuse polarity when using direct current (DC).
- Do not apply a commercial power source to the sensor which is connected to the input terminal nor allow the power source to come into contact with the sensor.
- Use a thermocouple and compensating lead wire according to the sensor input specifications of this controller.
- Use the 3-wire RTD according to the sensor input specifications of this controller.
- For DC voltage input, (+) side input terminal number of 0 to 5 V DC, 1 to 5 V DC, 0 to 10 V DC differs from that of 0 to 1 V DC.

Model	Terminal Number
BCS2	⑨: (+) side of 0 to 5 V DC, 1 to 5 V DC, 0 to 10 V DC
	⑩: (+) side of 0 to 1 V DC
BCR2, BCD2	⑲: (+) side of 0 to 5 V DC, 1 to 5 V DC, 0 to 10 V DC
	⑳: (+) side of 0 to 1 V DC

- When using a relay contact output type, externally use a relay according to the capacity of the load to protect the built-in relay contact.
- When wiring, keep input wires (thermocouple, RTD, etc.) away from controller AC power sources or load wires.

3. Operation and Maintenance Precautions

Caution

- It is recommended that AT be performed on the trial run.
- Do not touch live terminals. This may cause electrical shock or problems in operation.
- Turn the power supply to the instrument OFF when retightening the terminal or cleaning.
Working on or touching the terminal with the power switched ON may result in severe injury or death due to electrical shock.
- Use a soft, dry cloth when cleaning the instrument.
(Alcohol based substances may tarnish or deface the unit.)
- As the display section is vulnerable, be careful not to put pressure on, scratch or strike it with a hard object.

Contents

	Page
1. Model	
1.1 Model -----	7
1.2 How to Read the Model Label -----	8
2. Names and Functions of Controller -----	9
3. Mounting to the Control Panel	
3.1 External Dimensions (Scale: mm) -----	12
3.2 Panel Cutout (Scale: mm) -----	13
3.3 CT (Current Transformer) External Dimensions (Scale: mm) -----	14
3.4 Mounting to, and Removal from, the Control Panel	
3.4.1 How to Mount the Unit -----	15
3.4.2 How to Remove the Mounting Frame and Unit -----	17
4. Wiring	
4.1 Terminal Arrangement -----	19
4.2 Lead Wire Solderless Terminal -----	20
4.3 Terminal Cover -----	21
4.4 Wiring	
4.4.1 Power Supply -----	22
4.4.2 Control Output OUT1, OUT2 -----	22
4.4.3 Input -----	23
4.4.4 Event Output 1, Event Output 2 -----	24
4.4.5 Insulated Power Output -----	24
4.4.6 CT Input -----	25
4.4.7 Serial Communication -----	27
4.4.8 Event Input -----	29
4.4.9 External Setting Input -----	29
4.4.10 Transmission Output -----	29
5. Outline of Key Operation and Each Mode	
5.1 Key Operation -----	30
5.2 Modes -----	32
5.3 Basic Operation after Power-ON -----	33
6. Initial Setting -----	37
6.1 Example of Initial Setting -----	38
6.2 Initial Setting Mode -----	40
7. Settings	
7.1 Main Setting Mode -----	53
7.2 Sub Setting Mode -----	58
7.3 Engineering Mode 1 -----	64
7.4 Engineering Mode 2 -----	79
8. Operation and Settings of Standard Functions	
8.1 Selecting an input type -----	80
8.2 Selecting PID Control or ON/OFF Control -----	81
8.3 Selecting Direct/Reverse Action -----	82
8.4 Performing Fixed Value Control -----	83
8.5 Setting PID Constants (by Performing AT) -----	84
8.5.1 Usual AT -----	84
8.5.2 AT on Startup -----	85
8.6 Performing Auto-reset -----	87
8.7 Performing Program Control -----	88
8.8 Event Output EV1 Allocation -----	95
8.9 Indicating MV, Remaining Time (Program Control) -----	97
8.10 Items to be Initialized by Changing Settings -----	98

9. Attached Function	
9.1 Input Value Correction -----	99
9.2 Set Value Lock -----	101
9.3 Control Output OFF Function -----	102
9.4 Switching Auto/Manual Control (Auto/Manual Control Function) -----	103
9.5 Using as a Converter -----	104
9.5.1 Selecting Converter Function -----	105
9.5.2 Fine Adjustment of Converter Output (4 to 20 mA DC) -----	106
9.5.3 Converter Setting Example -----	107
9.6 Clearing Data -----	108
10. Action Explanation	
10.1 OUT1 Action -----	109
10.2 OUT1 ON/OFF Control Action -----	109
10.3 Heater Burnout Alarm Action -----	110
10.4 Alarm Action -----	111
10.5 OUT2 (Heating/Cooling Control) Action -----	113
10.6 OUT2 (Heating/Cooling Control) Action (When Setting Dead Band) -	114
10.7 OUT2 (Heating/Cooling Control) Action (When Setting Overlap Band)-	115
11. Specifications	
11.1 Standard Specifications -----	116
11.2 Optional Specifications -----	127
12. Troubleshooting	
12.1 Indication -----	129
12.2 Key Operation -----	131
12.3 Control -----	132
13. Character Table	
13.1 Error Code -----	133
13.2 Run Mode -----	133
13.3 Monitor Mode -----	133
13.4 Initial Setting Mode -----	134
13.5 Main Setting Mode -----	140
13.6 Sub Setting Mode -----	142
13.7 Engineering Mode 1 -----	144
13.8 Engineering Mode 2 -----	150
14. Key Operation Flowchart -----	151

1. Model

1.1 Model

B C <input type="checkbox"/> 2 <input type="checkbox"/> <input type="checkbox"/> <input type="checkbox"/> - <input type="checkbox"/> <input type="checkbox"/>						
Size	BCS2					48 x 48 x 68 mm (W x H x D) (Depth of control panel interior: 60)
	BCR2					48 x 96 x 68 mm (W x H x D) (Depth of control panel interior: 60)
	BCD2					96 x 96 x 68 mm (W x H x D) (Depth of control panel interior: 60)
Control output OUT1	R					Relay contact: 1a
	S					Non-contact voltage (for SSR drive) 12 V DC ± 15%
	A					Direct current: 4 to 20 mA DC
Power supply voltage	0					100 to 240 V AC (Standard)
	1					24 V AC/DC
Input		0				Multi-range (*1)
Option 1 (*2) (Choose only one option.)		0				No Option 1 needed.
		1	EV2			Event output EV2 (*3)
		2	DS			Heating/Cooling control output OUT2, Non-contact voltage
		3	DA			Heating/Cooling control output OUT2, Direct current
		4	P24			Insulated power output
		5	EV2+DR(*4)			Event output EV2 (*3) + Heating/Cooling control output OUT2, Relay contact
		6	EV2+DS(*4)			Event output EV2 (*3) + Heating/Cooling control output OUT2, Non-contact voltage
		7	EV2+DA(*4)			Event output EV2 (*3) + Heating/Cooling control output OUT2, Direct current
Option 2 (*2) (Choose only one option.)		0				No Option 2 needed.
		1	C5W (20A)			Event input (2 points) (*5) + Serial communication + Heater burnout alarm (20A) (*6)
		2	C5W (100A)			Event input (2 points) (*5) + Serial communication + Heater burnout alarm (100A) (*6)
		3	EIW (20A)			Event input (2 points) + Heater burnout alarm (20A) (*6)
		4	EIW (100A)			Event input (2 points) + Heater burnout alarm (100A) (*6)
		5	EIT (*4)			Event input (2 points) (*7)+ External setting input + Transmission output
		6	C5			Serial communication
		7	W (20A)			Heater burnout alarm (20 A) (*6)
		8	W (100A)			Heater burnout alarm (100 A) (*6)
		9	EI			Event input (2 points)

(*1) Thermocouple, RTD, Direct current and DC voltage can be selected by keypad.

(*2) Only one option can be selected from Option 1 and Option 2 respectively.

(*3) Event output EV1 is standard.

The following outputs can be selected in [Event output EV1/EV2 allocation] by keypad:

Alarm output (12 alarm types and No alarm action), Heater burnout alarm output, Loop break alarm output, Time signal output, Output during AT, Pattern end output, Output by communication command, Heating/Cooling control output OUT2 (for EV2 option only).

For Event output EV1/EV2, Heater burnout alarm output and Output by communication command are available when C5W, EIW, C5 or W option is ordered.

(*4) When EV2+D□ option and EIT option are added simultaneously, Transmission output terminals are used for EV2 output, so Transmission output is disabled. For the BCS2, EV2+D□ cannot be selected.

(*5) For the BCS2, Event input (2 points) is not available.

(*6) For direct current output type, Heater burnout alarm does not work.

(*7) For the BCS2, 1 point of Event input is available.

1.2 How to Read the Model Label

The model label is attached to the right side of the case.

BCS2

(e.g.) BCS2R00-12

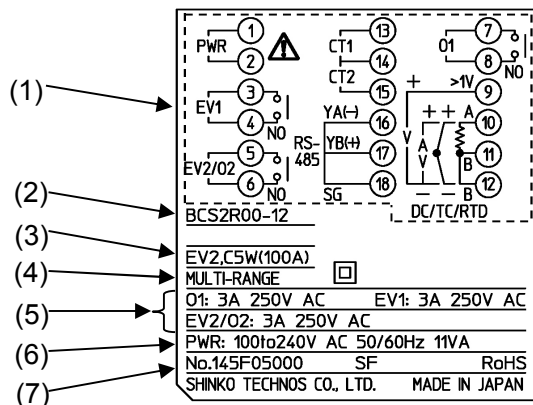

(Fig. 1.2-1)

BCR2, BCD2

(e.g.) BCD2R00-12

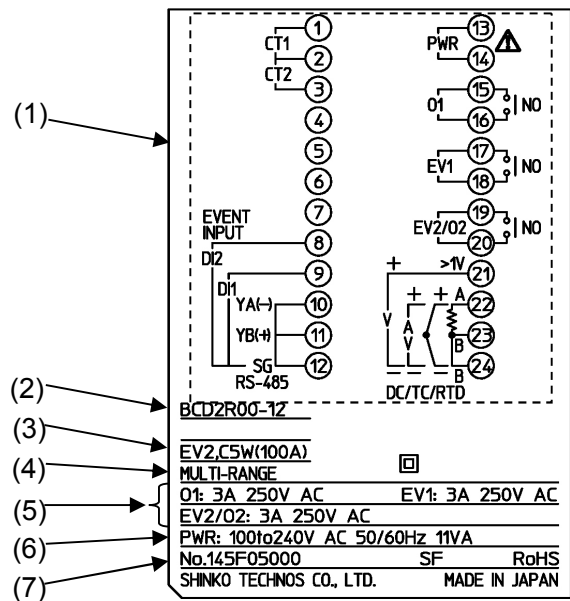

(Fig. 1.2-2)

No.	Description	Example
(1)	Terminal arrangement	BCS2R00-12, BCD2R00-12 (*1)
(2)	Model	BCS2R00-12, BCD2R00-12
(3)	Option	EV2 (Event output EV2) C5W(100A) [Serial communication + Heater burnout alarm (100 A)] (*2)
(4)	Input	MULTI-RANGE (Multi-range input)
(5)	Control output, Event output	O1: 3 A 250 V AC (Control output OUT1) EV1: 3 A 250 V AC (Event output EV1) EV2: 3 A 250 V AC (Event output EV2)
(6)	Power supply voltage, Power consumption	100 to 240 V AC 50/60 Hz, 11 VA
(7)	Serial number	No. 145F05000

(*1) Terminal arrangement diagram differs depending on the model.

(*2) For Heater burnout alarm output (C5W, EIW, W options), CT rated current is entered in bracket ().

2. Names and Functions of Controller

BCS2

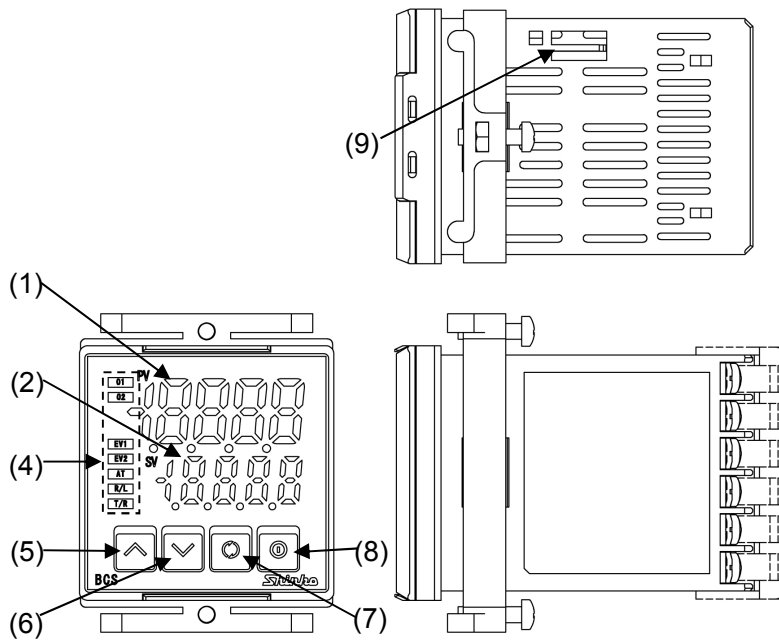

(Fig. 2-1)

BCR2

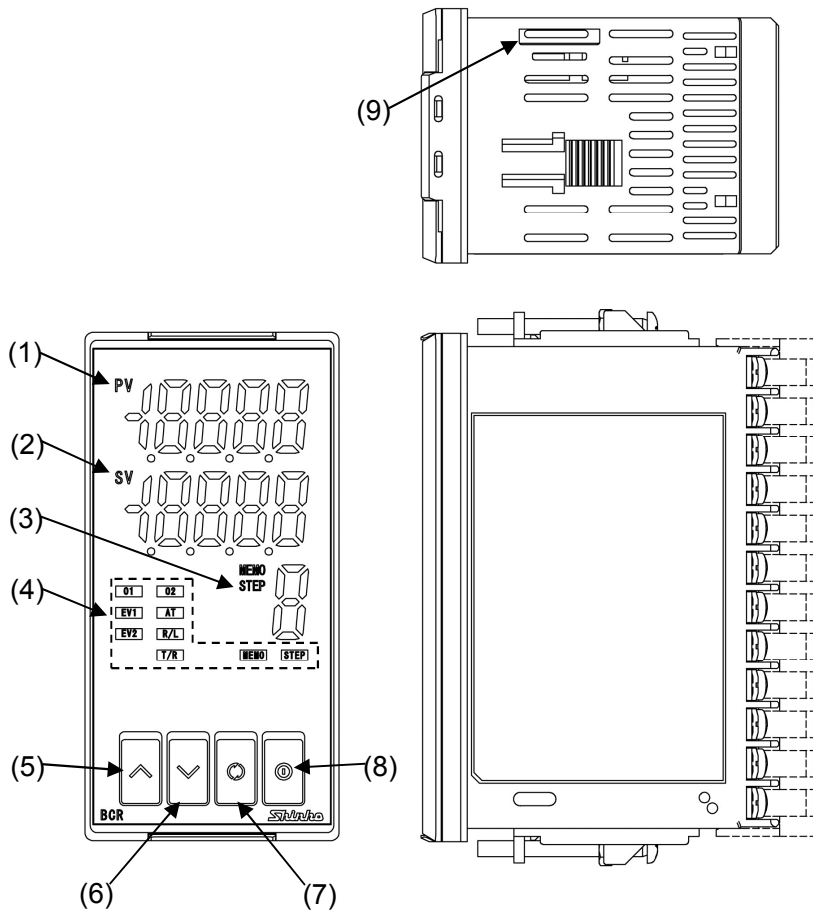

(Fig. 2-2)

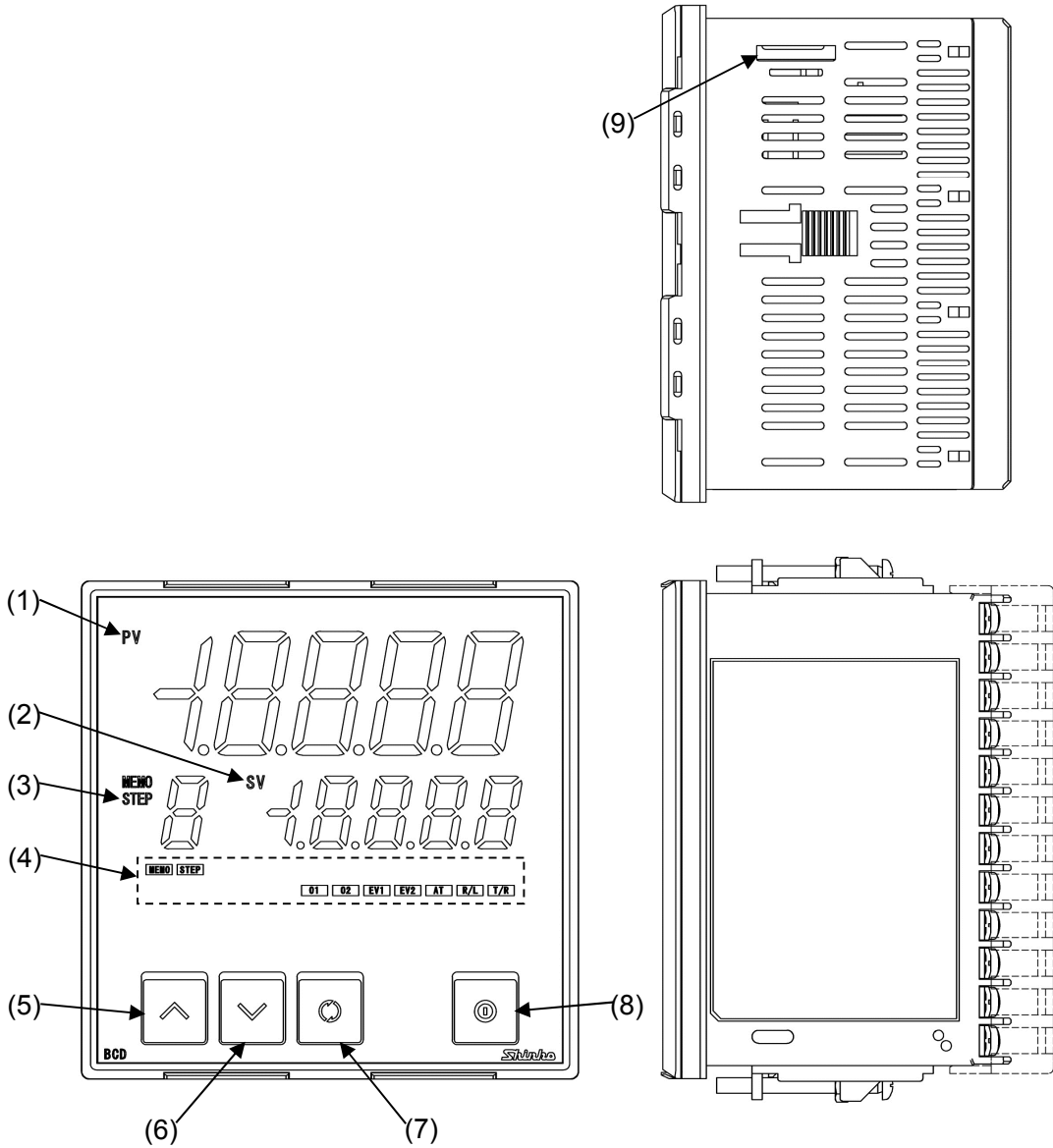

(Fig. 2-3)

Display

No.	Name	Description	
(1)	PV Display	Indicates PV. Indicates setting characters in each setting mode.	
(2)	SV Display	Indicates SV. Indicates the set data in each setting mode. In Monitor mode, indicated contents differ depending on the model as follows.	
		Model	Indicated Contents
		BCS2	Indicates MV, Remaining time (Program control), Step number (Program control) or Set value memory number (Fixed value control).
	BCR2, BCD2	Indicates MV or Remaining time (Program control).	
(3)	MEMO/STEP Display	Indicates Set value memory number (Fixed value control) or Step number (Program control). (For BCR2, BCD2)	

Action Indicators

No.	Name	Description
(4)	O1 (Green)	Lit when control output OUT1 is ON. For direct current output type, flashes corresponding to the MV in 125 ms cycles.
	O2 (Yellow)	Lit when control output OUT2 (EV2, DS, DA, EV2+D□ options) is ON. For direct current output type (DA option), flashes corresponding to the MV in 125 ms cycles.
	EV1 (Red)	Lit when Event output EV1 is ON.
	EV2 (Red)	Lit when Event output EV2 (EV2, EV2+D□ options) is ON. Unlit if □□ 19 (Heating/Cooling control relay contact output) is selected in [Event output EV2 allocation].
	AT (Yellow)	Flashes while AT, 'AT on startup' or Auto-reset is performing.
	R/L (Yellow)	Lit during Remote action, selected in [Remote/Local] (EIT option).
	T/R (Yellow)	Lit during Serial communication (C5W, C5 options) TX (transmitting) output.
	MEMO (Yellow)	Lit when Set value memory number (Fixed value control) is indicated. (For BCR2, BCD2)
	STEP (Green)	Lit when a step number (Program control) is indicated. (For BCR2, BCD2)

Key

No.	Name	Description	
(5)	UP key	Increases the numeric value. By pressing this key for 1 second during Program control, the performing step is interrupted, proceeding to the beginning of the next step. (Advance function)	
(6)	DOWN key	Decreases the numeric value.	
(7)	MODE key	Switches a setting mode, and registers the set data. By pressing this key for 3 seconds during RUN mode, the unit enters Monitor mode.	
(8)	OUT/OFF key	By pressing the © key for approx. 1 second, one of the following items selected in [OUT/OFF key function] is activated.	
		OUT/OFF Key Function	Description
		Control output OFF function	Turns control output ON or OFF.
		Auto/Manual control	Switches the Auto/Manual control.
		Program control	Starts/Stops the Program control.

Console Connector

No.	Name	Description
(9)	Console connector	By connecting the tool cable (CMD-001, sold separately), the following operations can be conducted from an external computer using the Console software SWC-BCx01M. <ul style="list-style-type: none"> • Reading and setting of SV, PID and various set values • Reading of PV and action status • Function change

3. Mounting to the Control Panel

3.1 External Dimensions (Scale: mm)

BCS2

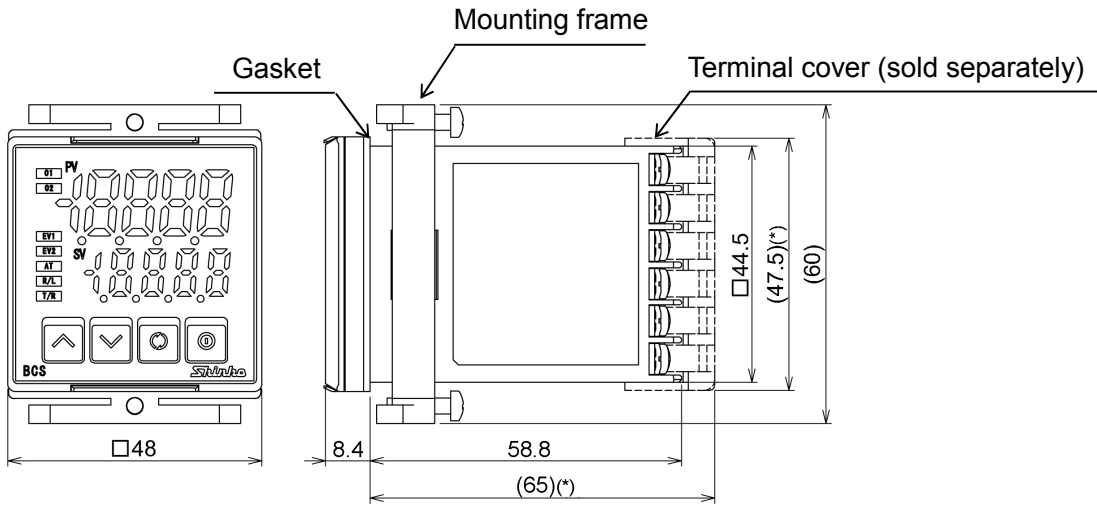

(*) When the terminal cover is used.

(Fig. 3.1-1)

BCR2

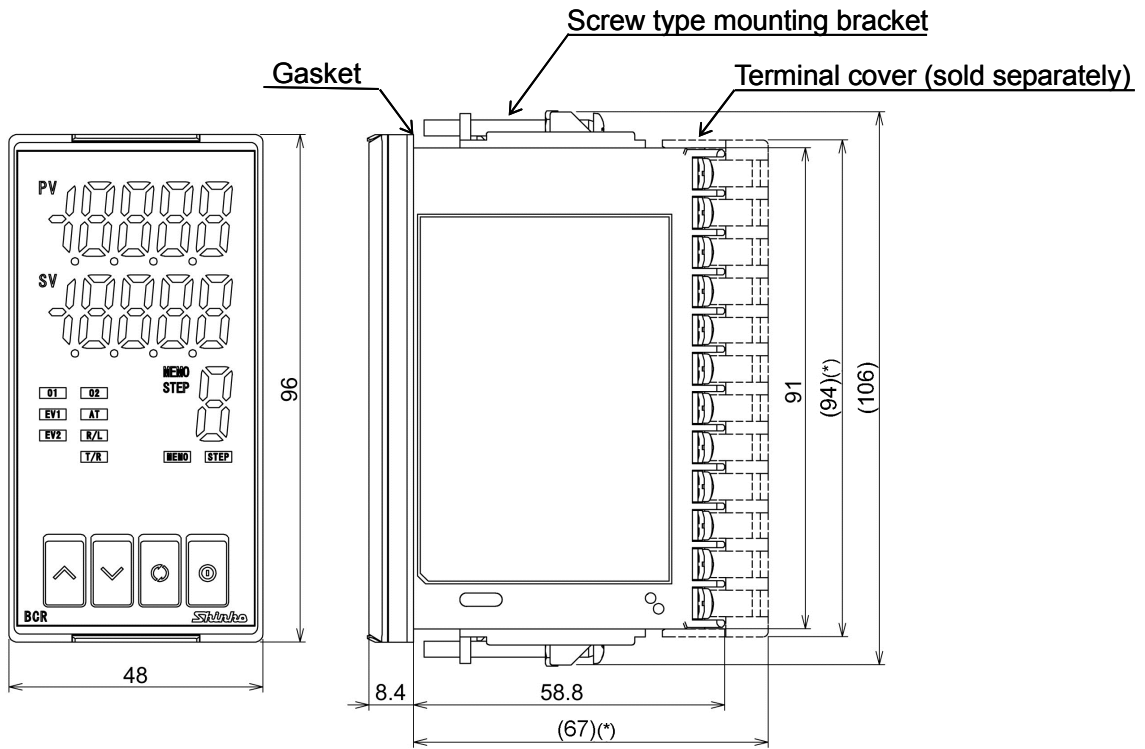

(*) When the terminal cover is used.

(Fig. 3.1-2)

BCD2

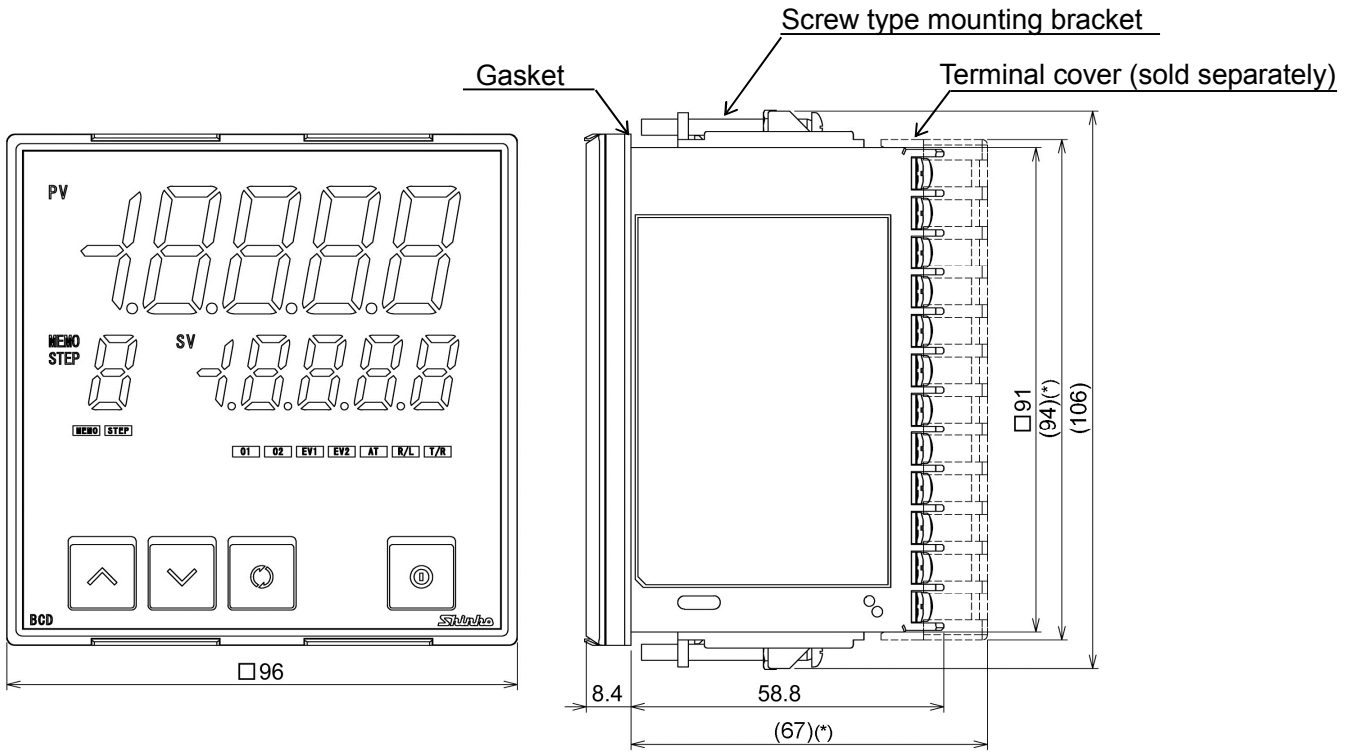

(*) When terminal covers are used.

(Fig. 3.1-3)

3.2 Panel Cutout (Scale: mm)

⚠ Caution

If horizontal close mounting is used for the controller, IP66 specification (Drip-proof/Dust-proof) may be compromised, and all warranties will be invalidated.

BCS2

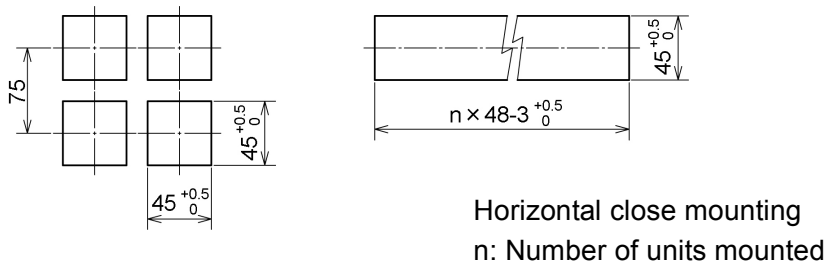

(Fig. 3.2-1)

BCR2

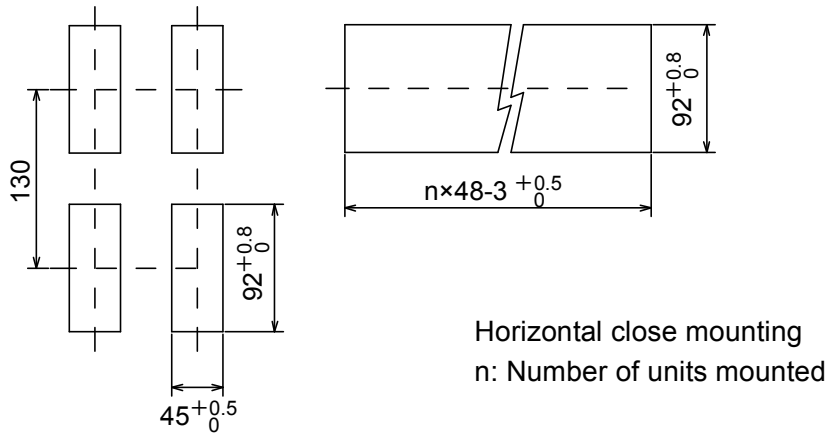

(Fig. 3.2-2)

BCD2

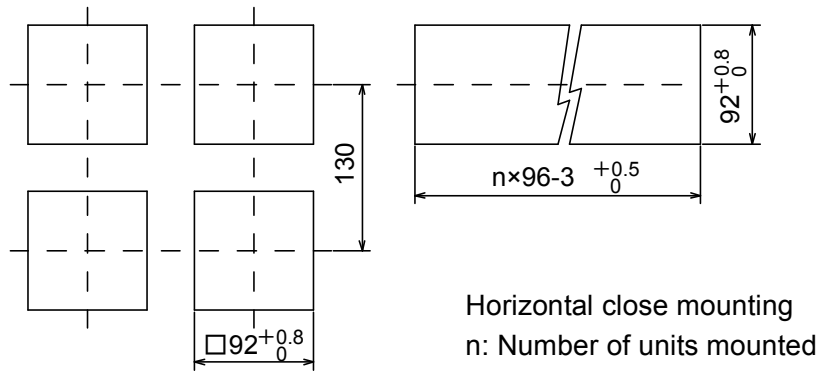

(Fig. 3.2-3)

3.3 CT (Current Transformer) External Dimensions (Scale: mm)

CTL-6-S-H (for 20 A)

CTL-12-S36-10L1U (for 100 A)

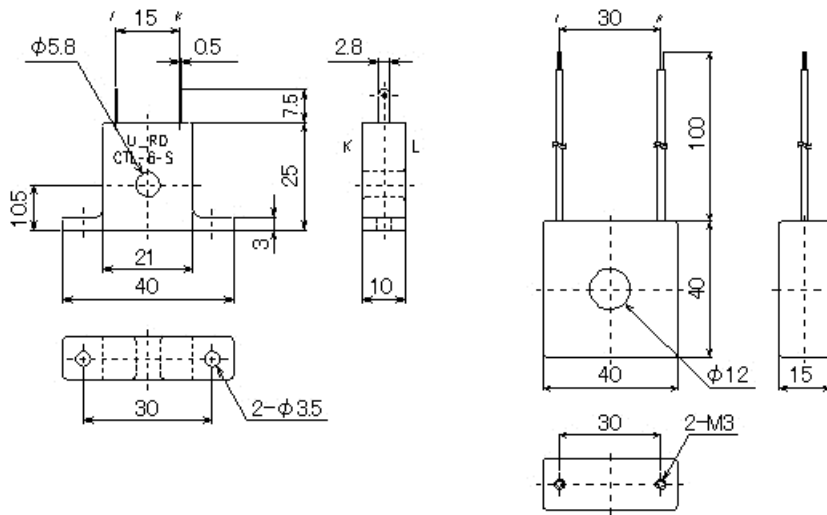

(Fig. 3.3-1)

3.4 Mounting to, and Removal from, the Control Panel



Caution

As the mounting frame of the BCS2 is made of resin, do not use excessive force while tightening screws, or the mounting frame could be damaged.

Tighten screws with one rotation upon the screw tips touching the panel.

The torque is 0.05 to 0.06 N•m.

For the BCR2, BCD2, the torque should be 0.1 N•m.

3.4.1 How to Mount the Unit

BCS2

Mount the controller vertically to the flat, rigid panel to ensure it adheres to the Drip-proof/Dust-proof specification (IP66).

If the lateral close mounting is used for the controller, IP66 specification (Drip-proof/Dust-proof) may be compromised, and all warranties will be invalidated.

Mountable panel thickness: 1 to 5 mm

(1) Insert the controller from the front side of the control panel. (Fig. 3.4.1-1)

If the Drip-proof/Dust-proof specification (IP66) is not necessary, the gasket may be removed (Please keep in mind the warranty is void if gasket is removed).

(2) Insert the mounting frame until it comes into contact with the panel, and fasten with screws.

Tighten screws with one rotation upon the screw tips touching the panel. (Fig. 3.4.1-2)

The torque is 0.05 to 0.06 N•m.

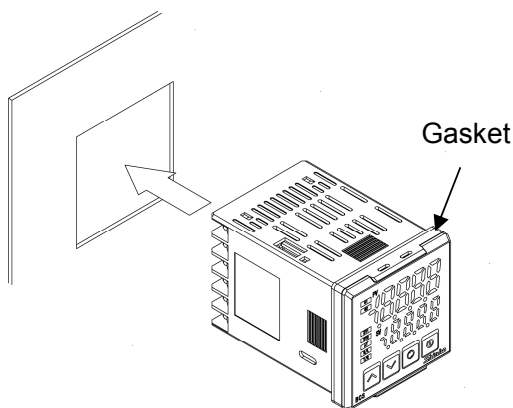

(Fig. 3.4.1-1)

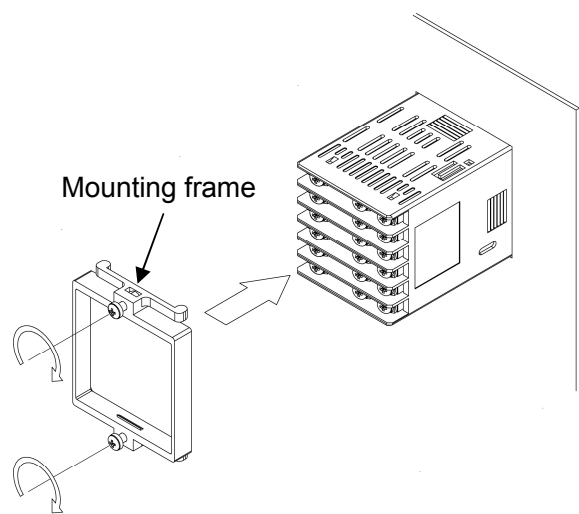

(Fig. 3.4.1-2)

BCR2, BCD2

Mount the controller vertically to the flat, rigid panel to ensure it adheres to the Drip-proof/Dust-proof specification (IP66).

If the lateral close mounting is used for the controller, IP66 specification (Drip-proof/Dust-proof) may be compromised, and all warranties will be invalidated.

Mountable panel thickness: 1 to 7 mm

(1) Insert the controller from the front side of the control panel. (Fig. 3.4.1-3)

If the Drip-proof/Dust-proof specification (IP66) is not necessary, the gasket may be removed.
(Please keep in mind the warranty is void if gasket is removed).

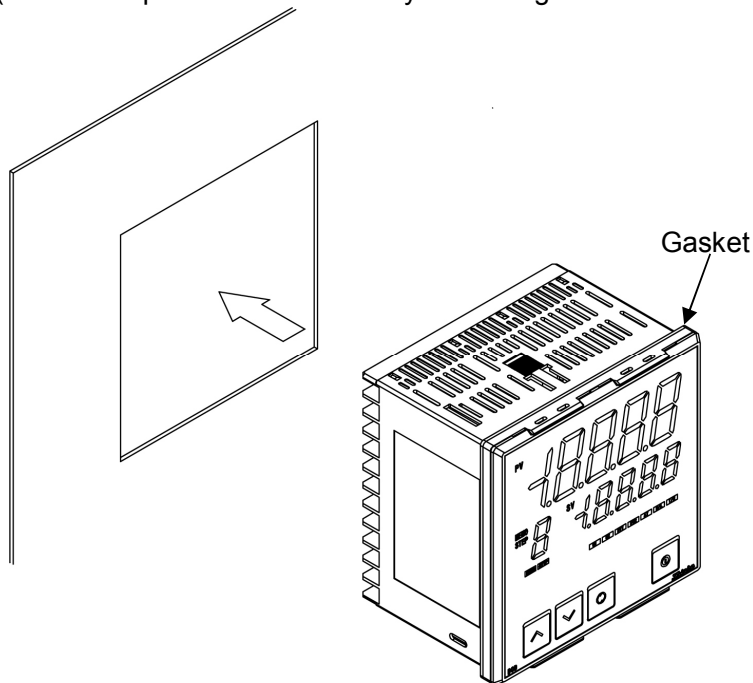

(Fig. 3.4.1-3)

(2) Attach the mounting brackets by the slots at the top and bottom of the case, and secure the controller in place with the screws.

The torque is 0.1 N•m.

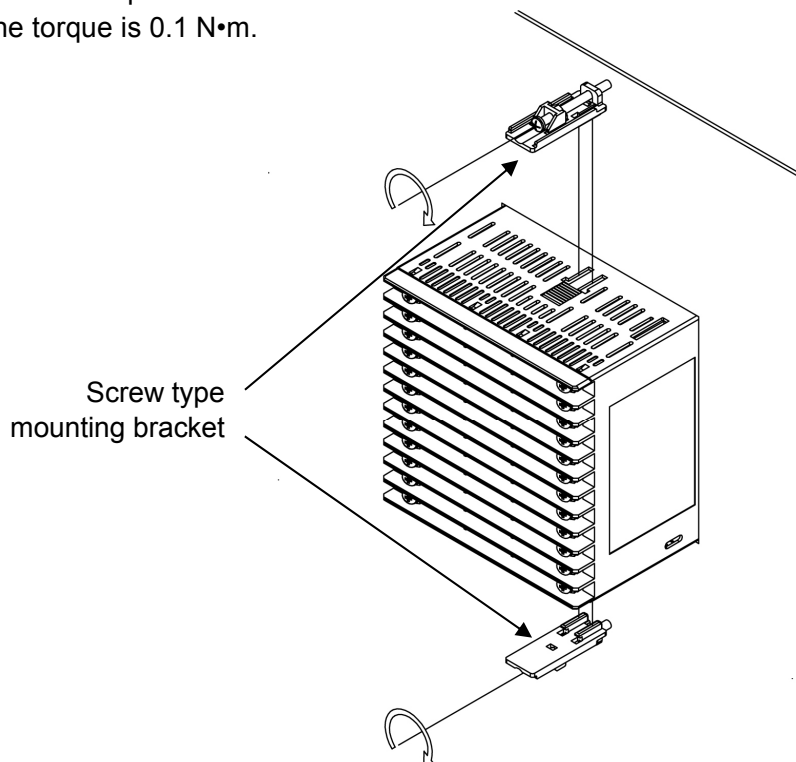

(Fig. 3.4.1-4)

3.4.2 How to Remove the Mounting Frame and Unit

BCS2 (Fig. 3.4.2-1)

- (1) Turn the power to the unit OFF, and disconnect all wires before removing the mounting frame.
 - (2) Insert a flat blade screwdriver between the mounting frame and unit (①).
 - (3) Slowly push the frame upward using the screwdriver (②), while pushing the unit toward the panel (③).
 - (4) Repeat step (2) and slowly push the frame downward using the screwdriver for the other side.
- The frame can be removed little by little by repeating these steps.

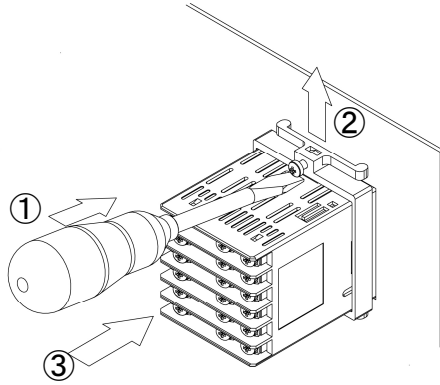

(Fig. 3.4.2-1)

BCR2, BCD2

- (1) Turn the power to the unit OFF, and disconnect all wires before removing the unit.
- (2) Loosen the screws of the mounting brackets, and remove the mounting brackets.
- (3) Pull the unit out from the front of the control panel.

4. Wiring

Warning

Turn the power supply to the instrument off before wiring or checking.

Working on or touching the terminal with the power switched on may result in severe injury or death due to electrical shock.

Caution

- Do not leave wire remnants in the instrument, as they could cause a fire or malfunction.
- Use the solderless terminal with an insulation sleeve in which the M3 screw fits when wiring the instrument.
- The terminal block of this instrument is designed to be wired from the left side. The lead wire must be inserted from the left side of the terminal, and fastened with the terminal screw.
- Tighten the terminal screw using the specified torque. If excessive force is applied to the screw when tightening, the terminal screw or case may be damaged.
- Do not pull or bend the lead wire on the terminal side when wiring or after wiring, as it could cause malfunction.
- When using a terminal cover for the BCS2, pass terminal wires numbered 7 to 12 into the holes of the terminal cover.
- This instrument does not have a built-in power switch, circuit breaker and fuse.
It is necessary to install a power switch, circuit breaker and fuse near the controller.
(Recommended fuse: Time-lag fuse, rated voltage 250 V AC, rated current 2 A)
- For a 24 V AC/DC power source, do not confuse polarity when using direct current (DC).
- Do not apply a commercial power source to the sensor which is connected to the input terminal nor allow the power source to come into contact with the sensor.
- Use a thermocouple and compensating lead wire according to the sensor input specifications of this controller.
- Use the 3-wire RTD according to the sensor input specifications of this controller.
- For DC voltage input, (+) side input terminal number of 0 to 5 V DC, 1 to 5 V DC, 0 to 10 V DC differs from that of 0 to 1 V DC.

Model	Terminal Number
BCS2	⑨: (+) side of 0 to 5 V DC, 1 to 5 V DC, 0 to 10 V DC ⑩: (+) side of 0 to 1 V DC
BCR2, BCD2	⑳: (+) side of 0 to 5 V DC, 1 to 5 V DC, 0 to 10 V DC ㉑: (+) side of 0 to 1 V DC

- When using a relay contact output type, externally use a relay according to the capacity of the load to protect the built-in relay contact.
- When wiring, keep input wires (thermocouple, RTD, etc.) away from AC sources or load wires.

4.1 Terminal Arrangement

Terminal arrangement of the BCS2, BCR2, BCD2 differs depending on the options as follows.

BCS2

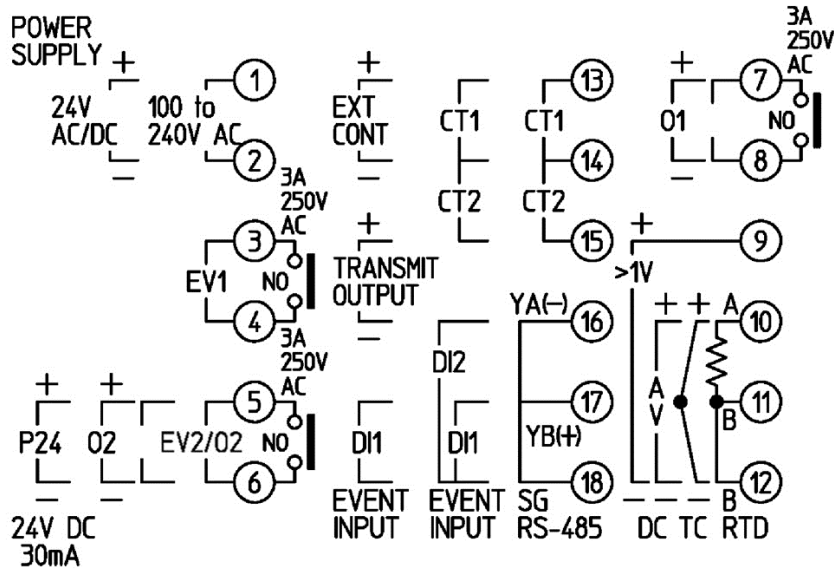

(Fig. 4.1-1)

BCR2, BCD2

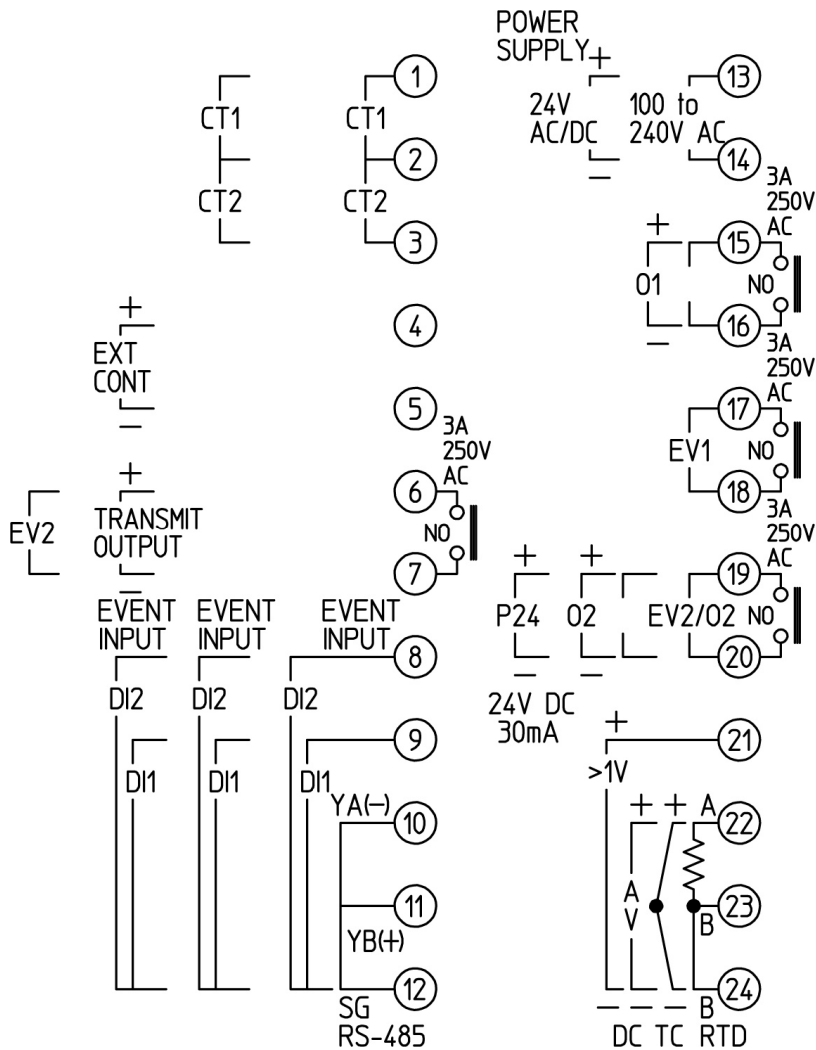

(Fig. 4.1-2)

Terminal	Description						
POWER SUPPLY	100 to 240 V AC or 24 V AC/DC For a 24 V AC/DC power source, do not confuse polarity when using direct current (DC).						
EV1	Event output EV1						
EV2	Event output EV2 (EV2, EV2+D□ options)						
O2	Control output OUT2 (EV2, DS, DA, EV2+D□ options)						
P24	24 V DC insulated power output (P24 option)						
O1	Control output OUT1						
RTD	RTD input						
TC	Thermocouple input						
DC	Direct current, DC voltage inputs For DC voltage input, (+) side input terminal number of 0 to 5 V DC, 1 to 5 V DC, 0 to 10 V DC differs from that of 0 to 1 V DC.						
	<table border="1"> <thead> <tr> <th>Model</th> <th>Terminal Number</th> </tr> </thead> <tbody> <tr> <td>BCS2</td> <td>⑨: + side of 0 to 5 V DC, 1 to 5 V DC, 0 to 10 V DC ⑩: + side of 0 to 1 V DC</td> </tr> <tr> <td>BCR2, BCD2</td> <td>⑲: + side of 0 to 5 V DC, 1 to 5 V DC, 0 to 10 V DC ⑳: + side of 0 to 1 V DC</td> </tr> </tbody> </table>	Model	Terminal Number	BCS2	⑨: + side of 0 to 5 V DC, 1 to 5 V DC, 0 to 10 V DC ⑩: + side of 0 to 1 V DC	BCR2, BCD2	⑲: + side of 0 to 5 V DC, 1 to 5 V DC, 0 to 10 V DC ⑳: + side of 0 to 1 V DC
Model	Terminal Number						
BCS2	⑨: + side of 0 to 5 V DC, 1 to 5 V DC, 0 to 10 V DC ⑩: + side of 0 to 1 V DC						
BCR2, BCD2	⑲: + side of 0 to 5 V DC, 1 to 5 V DC, 0 to 10 V DC ⑳: + side of 0 to 1 V DC						
CT1	CT input 1 (C5W, EIW, W options)						
CT2	CT input 2 (C5W, EIW, W options)						
RS-485	Serial communication RS-485 (C5W, C5 options)						
EVENT INPUT	Event input DI1 (BCS2: EIW, EIT, EI options, BCR2/BCD2: C5W, EIW, EIT, EI options) Event input DI2 (BCS2: EIW, EI options, BCR2/BCD2: C5W, EIW, EIT, EI options)						
EXT CONT	External setting input (EIT option)						
TRANSMIT OUTPUT	Transmission output (EIT option) or Event output EV2 (EV2+D□ option) BCR2, BCD2: If EV2+D□ option and EIT option are added simultaneously, Transmission output terminals are used for EV2 output, so Transmission output will be disabled.						

4.2 Lead Wire Solderless Terminal

Use a solderless terminal with an insulation sleeve in which an M3 screw fits as shown below. The torque should be 0.63 N•m.

Solderless Terminal	Manufacturer	Model	Tightening Torque
Y-type	Nichifu Terminal Industries Co., Ltd.	TMEV1.25Y-3	0.63 N•m
	Japan Solderless Terminal MFG Co., Ltd.	VD1.25-B3A	
Ring-type	Nichifu Terminal Industries Co., Ltd.	TMEV1.25-3	
	Japan Solderless Terminal MFG Co., Ltd.	V1.25-3	

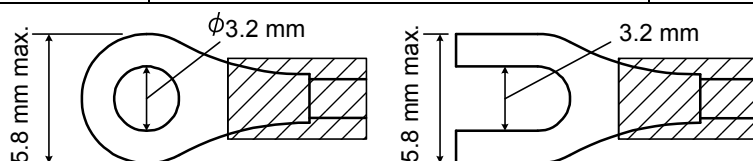

(Fig. 4.2-1)

4.3 Terminal Cover

BCS2

When using a terminal cover (sold separately), make sure the longer side is on the back right side of the case.

Pass the wires from terminals 7 to 12 into the holes of the terminal cover.

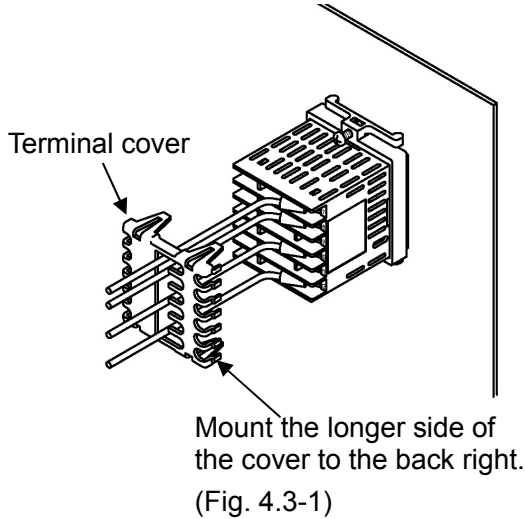

BCR2

When using a terminal cover (sold separately), make sure the longer side is on the back right side of the case.

Pass the wires from terminals 13 to 24 through the left side of the terminal cover.

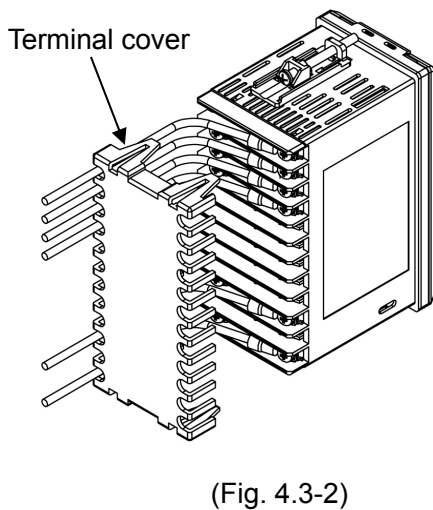

Top of BCR2

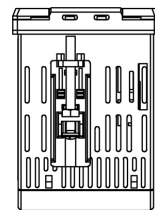

Mount the longer side of the cover to the back right.

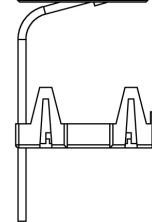

(Fig. 4.3-3)

BCD2

When using terminal covers (sold separately), make sure the longer side is on the back right and left sides of the case.

Pass the wires from terminals 13 to 24 through between covers.

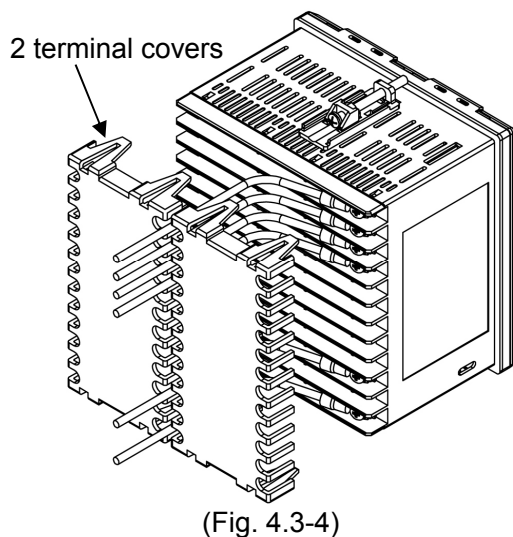

Top of BCD2

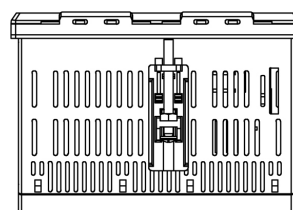

Mount the longer side of the cover to the back right and left.

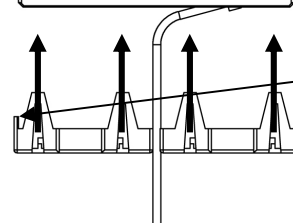

(Fig. 4.3-5)

4.4 Wiring

For the terminal arrangement, refer to Section '4.1 Terminal Arrangement' (p.19).

4.4.1 Power Supply

Power supply voltage is 100 to 240 V AC or 24 V AC/DC.

For a 24 V AC/DC power source, ensure polarity is correct when using direct current (DC).

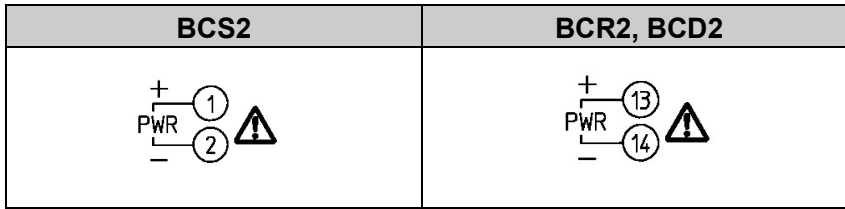

4.4.2 Control Output OUT1, OUT2

When EV2, DS, DA or EV2+D□ option is ordered, control output OUT2 is available.

Specifications of Control output OUT1, OUT2 are shown below.

Relay contact	1a Control capacity: 3 A 250 V AC (resistive load), 1 A 250 V AC (inductive load $\cos\phi=0.4$) Electrical life: 100,000 cycles Minimum applicable load: 10 mA 5 V DC
Non-contact voltage (for SSR drive)	12 V DC $\pm 15\%$ Max. 40 mA (short circuit protected)
Direct current	4 to 20 mA DC Load resistance: Max. 550 Ω

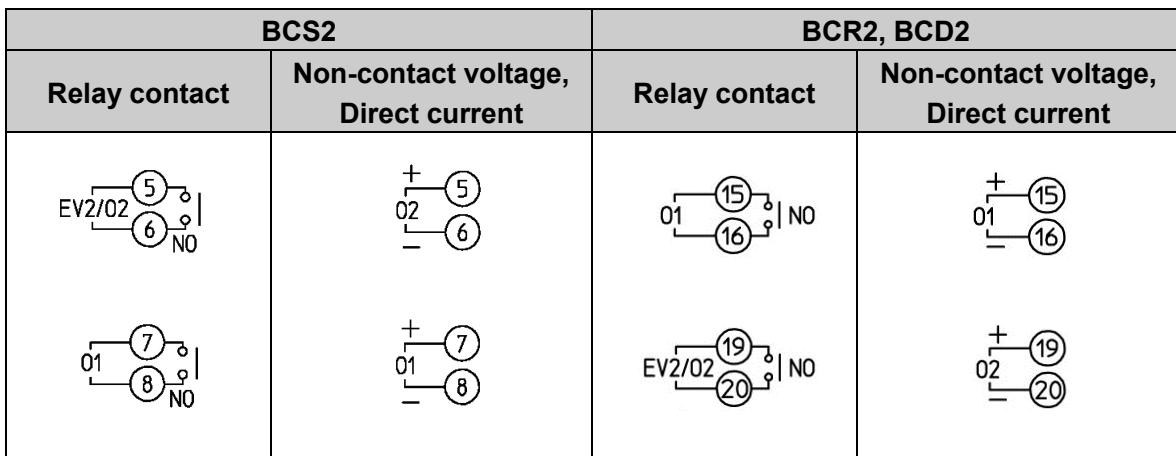

Number of Shinko SSR units when connected in parallel (for Non-contact voltage output):



- SA-400 series: 5 units
- SA-500 series: 2 units

4.4.3 Input

Each input wiring is shown below.

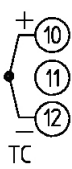
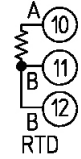
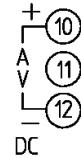
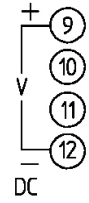
For DC voltage input, (+) side input terminal number of 0 to 5 V DC, 1 to 5 V DC, 0 to 10 V DC differs from that of 0 to 1 V DC.

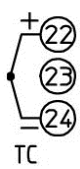
BCS2			
Thermocouple	RTD	Direct current, DC voltage (0 to 1 V)	DC voltage (0 to 5 V, 1 to 5 V, 0 to 10 V)
 <p>TC</p>	 <p>RTD</p>	 <p>DC</p>	 <p>DC</p>

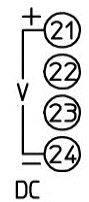
BCR2, BCD2			
Thermocouple	RTD	Direct current, DC voltage (0 to 1 V)	DC voltage (0 to 5 V, 1 to 5 V, 0 to 10 V)
 <p>TC</p>	 <p>RTD</p>	 <p>DC</p>	 <p>DC</p>

4.4.4 Event Output 1, Event Output 2

Event output EV1 is a standard feature.

If EV2 or EV2+D□ option is ordered, Event output EV2 is available.

Specifications of Event output 1 and Event output 2 are shown below.

Relay contact	1a Control capacity: 3 A 250 V AC (resistive load) 1 A 250 V AC (inductive load $\cos\phi=0.4$) Electrical life: 100,000 cycles Minimum applicable load: 10 mA 5 V DC
---------------	--

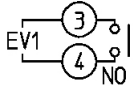
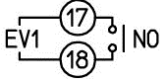
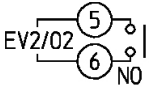
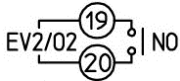
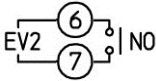

BCS2	BCR2, BCD2	
		
	For EV2 option	For EV2+D□ option
		

4.4.5 Insulated Power Output

If P24 option is ordered, the Insulated power output is available.

Specifications of Insulated power output are shown below.

Output voltage	24±3 V DC (at load current 30 mA DC)
Ripple voltage	Within 200 mV DC (at load current 30 mA DC)
Max load current	30 mA DC

BCS2	BCR2, BCD2
	

4.4.6 CT Input

CT input is available when Heater burnout alarm (C5W, EIW, W options) is ordered.

Cannot be used for detecting heater current under phase control.

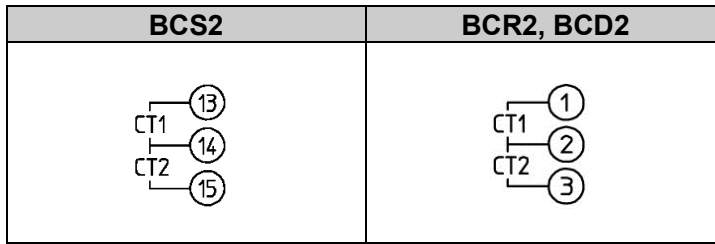

Use the CT (current transformer) provided, and pass one lead wire of the heater circuit into the hole of the CT. (Fig. 4.4.6-1)

When wiring, keep the CT wire away from AC sources or load wires to avoid the external interference.

BCS2

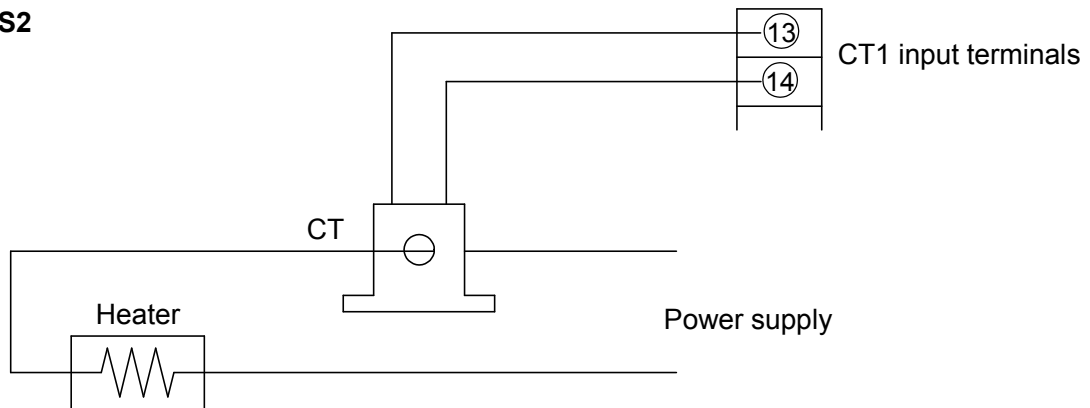

(Fig. 4.4.6-1)

If using 3-phase, pass any 2 lead wires of R, S, T into the CT, and connect them to CT1 (13, 14) and CT2 (14, 15) terminals. (Fig. 4.4.6-2)

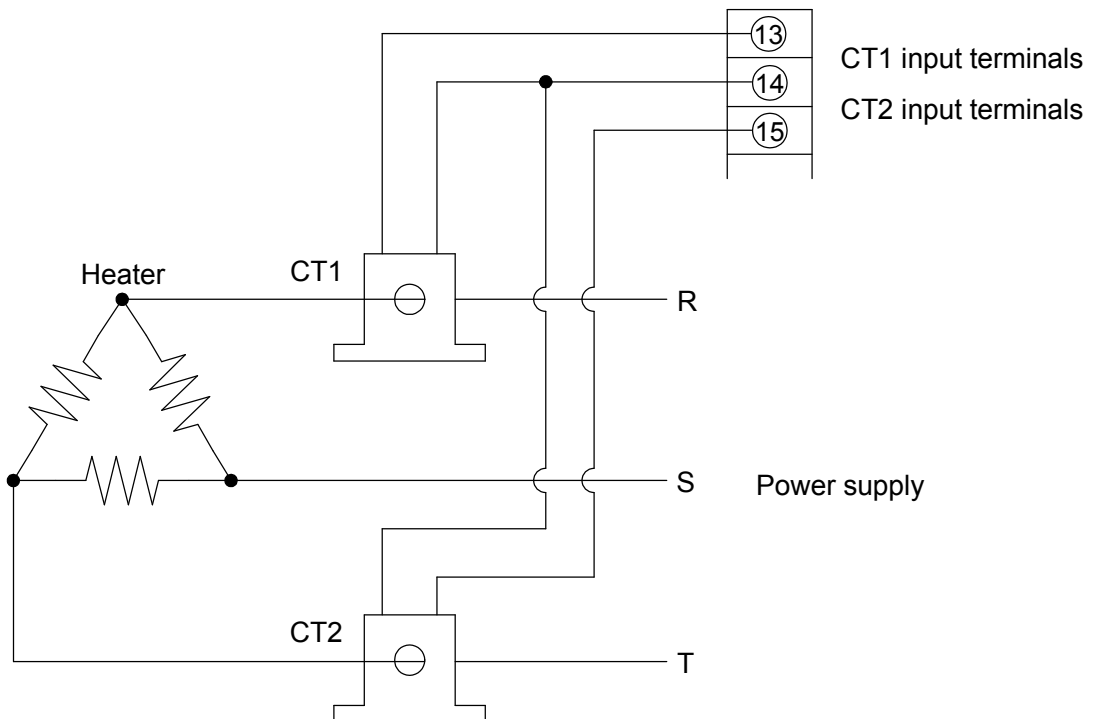

(Fig. 4.4.6-2)

BCR2, BCD2

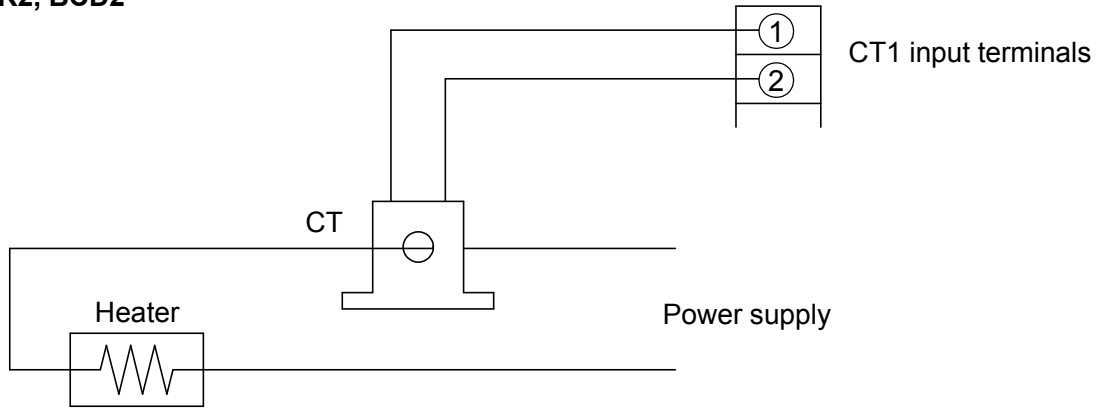

(Fig. 4.4.6-3)

When using 3-phase, pass any 2 lead wires of R, S, T into the CT, and connect them to CT1 (①, ②) and CT2 (②, ③) terminals. (Fig. 4.4.6-4)

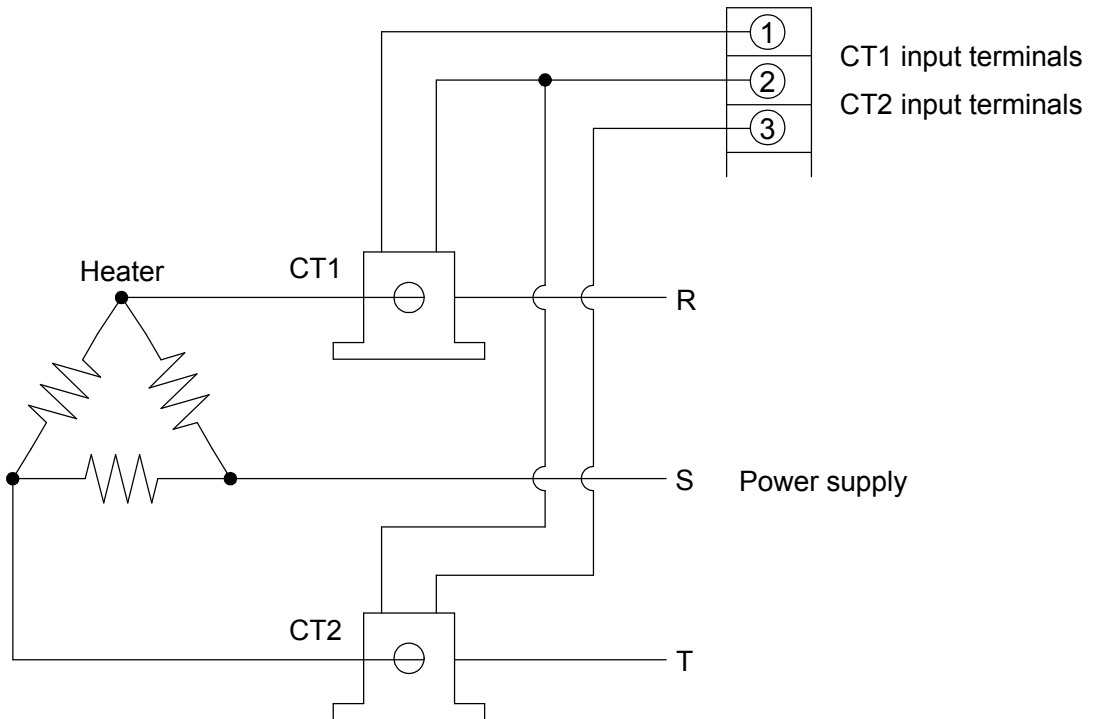

(Fig. 4.4.6-4)

4.4.7 Serial Communication

If the C5W or C5 option is ordered, Serial communication is available.

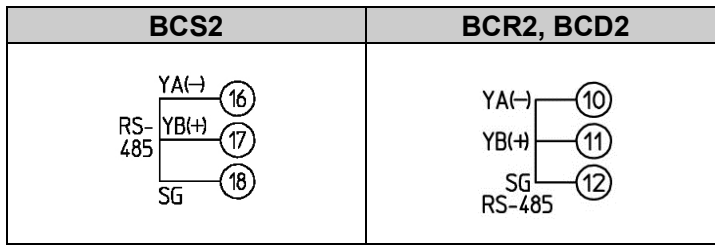

(1) Serial Communication

- When using USB communication cable CMC-001-1 (sold separately)

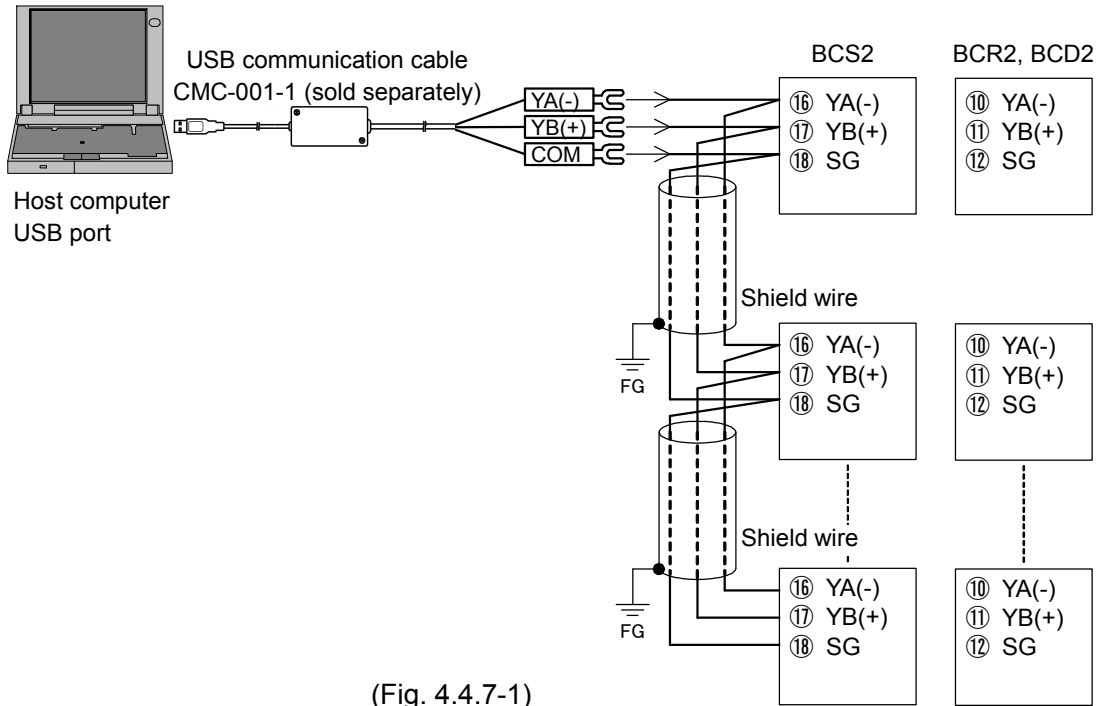

(Fig. 4.4.7-1)

- When using communication converter IF-400 (sold separately)

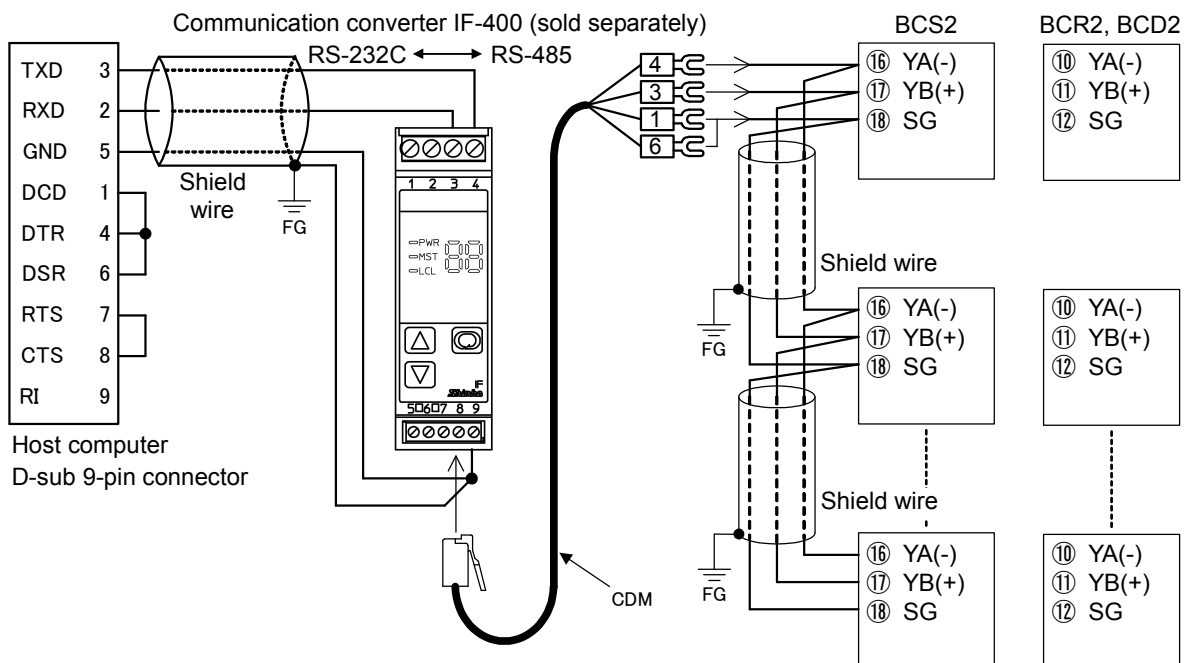

(Fig. 4.4.7-2)

(2) Set value digital transmission

By connecting to Shinko programmable controllers [PC-900 or PCD-33A with the SVTC (Set value digital transmission) option], digital SV via the SVTC command can be received from programmable controllers.

Wiring

For the PC-900, connect YA (-) to YA (-), YB (+) to YB (+), COM (PC-900) to SG (BCx2) terminal respectively.

For the PCD-33A, connect YA (-) to YA (-), YB (+) to YB (+), SG to SG terminal respectively.

Up to 31 units of the BCS2 or BCR2 or BCD2 can be connected.

The following shows a connection example of PCD-33A and BCS2, BCR2, BCD2. (Fig. 4.4.7-3)

Wiring example of PCD-33A and BCx2

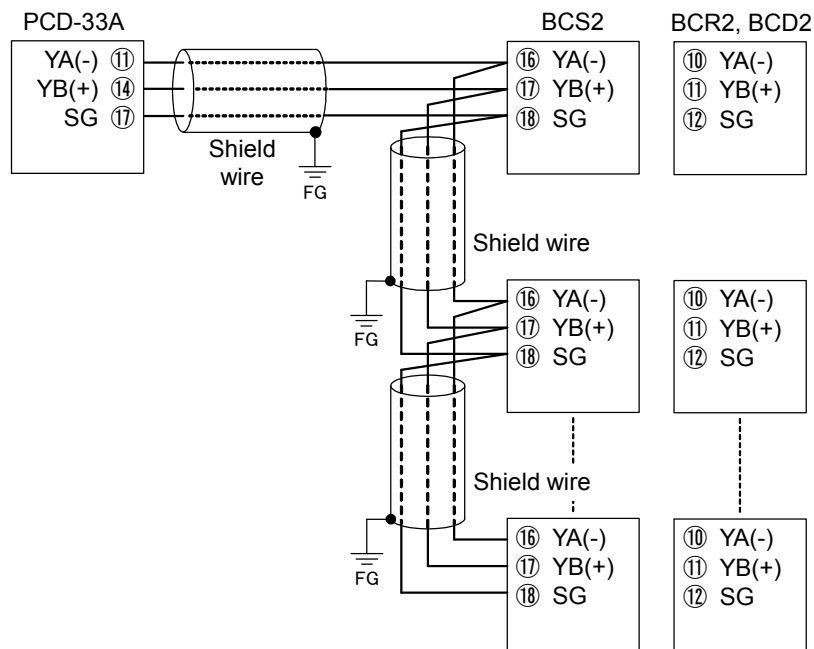

(Fig. 4.4.7-3)

Shield wire

Connect only one end of the shield to the FG terminal to avoid a ground loop. If both ends of the shield wire are connected to the FG terminal, the circuit will be closed, resulting in a ground loop. This may cause noise. Be sure to ground the FG terminal.

Recommended cable: OTSC-VB 2PX0.5SQ (made by Onamba Co., Ltd.) or equivalent (Use a twisted pair cable.)

4.4.8 Event Input

Event Input DI1 is available for the BCS2 with Event input (EIW, EIT, EI options).

Event Input DI1 is available for the BCR2, BCD2 with Serial communication (C5W option) or Event input (EIW, EIT, EI options).

Event Input DI2 is available for the BCS2 with Event input (EIW, EI options).

Event Input DI2 is available for the BCR2, BCD2 with Serial communication (C5W option) or Event input (EIW, EIT, EI options).

Specifications of Event input are shown below.

Circuit current when closed	Approx. 16 mA
-----------------------------	---------------

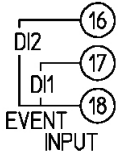
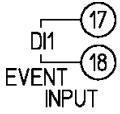
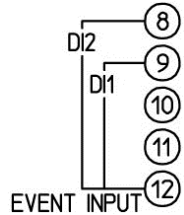
BCS2		BCR2, BCD2
EIW (20A), EIW (100A), EI	EIT	EIW (20A), EIW (100A), EIT, EI
		

4.4.9 External Setting Input

If the EIT option is ordered, External setting input is available.

Specifications of External setting input are shown below.

Setting signal	Direct current 4 to 20 mA DC
Allowable input	50 mA DC max.
Input impedance	50 Ω max.
Input sampling period	125 ms

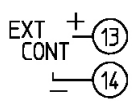
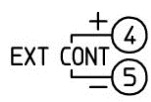
BCS2	BCR2, BCD2
	

4.4.10 Transmission Output

If the EIT option is ordered, Transmission output is available.

For the BCR2, BCD2, if EV2+D□ option and EIT option are added simultaneously, Transmission output terminals become EV2 output terminals, so Transmission output will be disabled.

Specifications of Transmission output are shown below.

Resolution	12000
Output	4 to 20 mA DC Load resistance: Max 550 Ω
Output accuracy	Within ±0.3% of Transmission output span

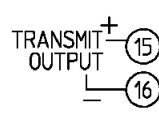
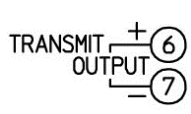
BCS2	BCR2, BCD2
	

5. Outline of Key Operation and Each Mode

5.1 key Operation

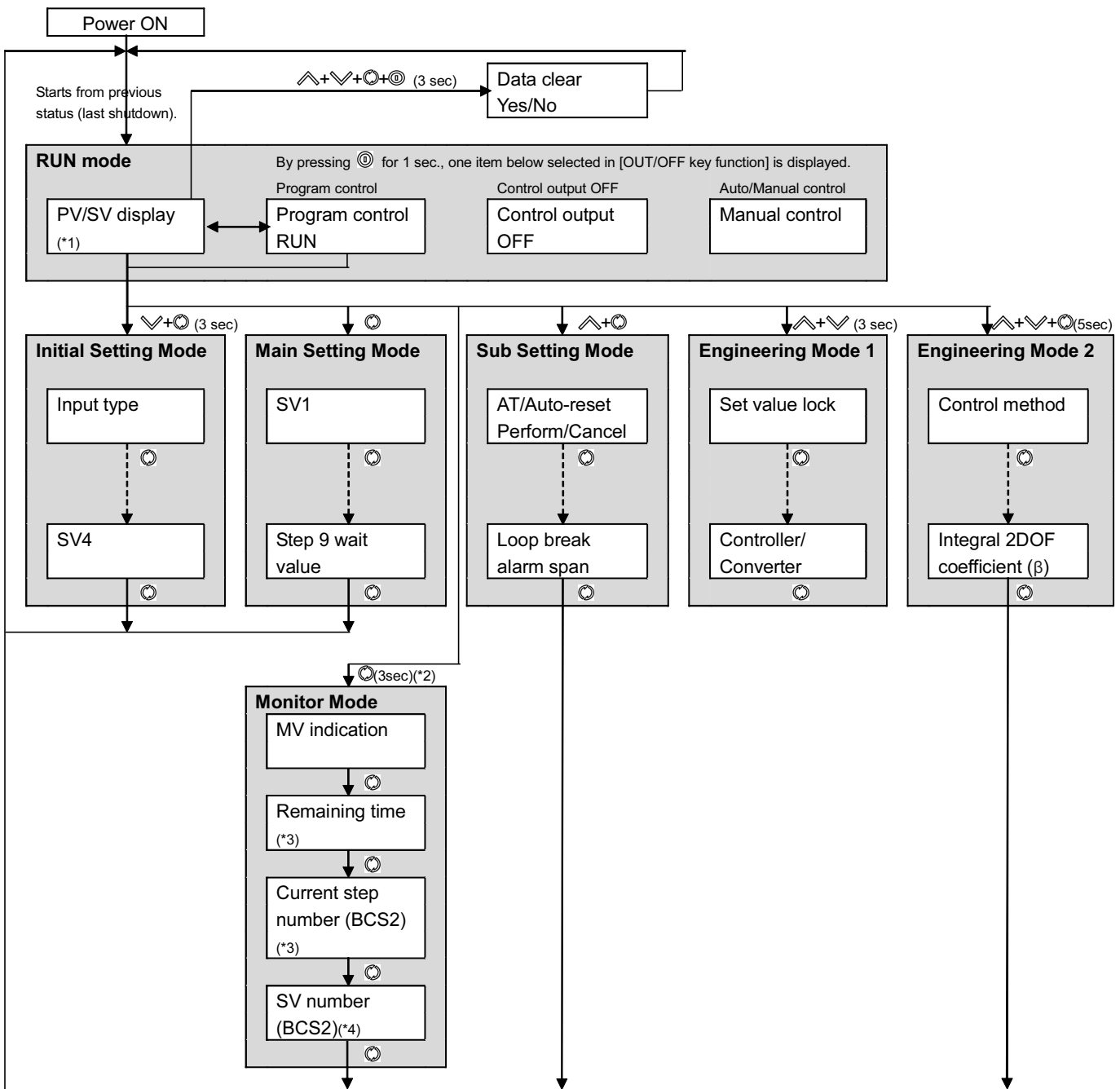





[Each Mode and Setting Item]

- (*1) If 'Program control' is selected in [OUT/OFF key function], the unit will enter Standby mode (program control waiting).
- (*2) The unit cannot proceed to Monitor mode if it is in Standby of program control.
- (*3) Available only when 'Program control' is selected in [OUT/OFF key function].
- (*4) Not available if 'Program control' is selected in [OUT/OFF key function].

[Key Operation]

- ⤴+⤵+⤶+⤷ (3 sec): Press and hold the ⤴, ⤵, ⤶ and ⤷ keys (in that order) together for approx. 3 sec.
- ⤵+⤶ (3 sec): Press and hold the ⤵ and ⤶ keys (in that order) together for approx. 3 sec.
- ⤴+⤶: Press and hold the ⤴ and ⤶ keys (in that order) together.
- ⤴+⤵ (3 sec): Press and hold the ⤴ and ⤵ keys (in that order) together for approx. 3 sec.
- ⤴+⤵+⤶ (5 sec): Press and hold the ⤴, ⤵ and ⤶ keys (in that order) together for approx. 5 sec.
- ⤶: If the ⤶ key is pressed, the unit will proceed to the next setting item, illustrated by an arrow.
By pressing the ⤶ key, the mode goes back to the previous mode.
- ⤶: Press the ⤶ key until the desired setting mode appears.

- Use the  or  key for settings or selections, and register them by pressing the  key.
- If the  key is pressed for approx. 3 seconds at each item, the unit will revert to the RUN mode.
- If the  key is pressed for approx. 3 seconds at each item, the following will be performed depending on the selection in [OUT/OFF key function].
 - If 'Control output OFF function' is selected in [OUT/OFF key function], the unit will enter Control output OFF status.
 - If 'Auto/Manual control' is selected in [OUT/OFF key function], the unit will enter Manual control status.
 - If 'Program control' is selected in [OUT/OFF key function], the unit will enter 'Program control RUN' or Standby mode.

5.2 Modes

Mode	Description								
RUN mode	When power is turned ON, the unit enters RUN mode. The PV Display indicates PV, and the SV Display indicates SV. Control starts from previous status (last shutdown). By pressing the \odot key for approx. 1 sec, one of the following functions is activated depending on the selection in [OUT/OFF key function].								
	<table border="1"> <thead> <tr> <th>OUT/OFF Key Function</th> <th>Description</th> </tr> </thead> <tbody> <tr> <td>Control output OFF function</td> <td>Turns the control output ON or OFF.</td> </tr> <tr> <td>Auto/Manual control</td> <td>Switches the Auto/Manual control.</td> </tr> <tr> <td>Program control</td> <td>Starts/Stops the Program control.</td> </tr> </tbody> </table>	OUT/OFF Key Function	Description	Control output OFF function	Turns the control output ON or OFF.	Auto/Manual control	Switches the Auto/Manual control.	Program control	Starts/Stops the Program control.
	OUT/OFF Key Function	Description							
	Control output OFF function	Turns the control output ON or OFF.							
Auto/Manual control	Switches the Auto/Manual control.								
Program control	Starts/Stops the Program control.								
Control output OFF function	Turns the control output ON or OFF.								
Auto/Manual control	Switches the Auto/Manual control.								
Program control	Starts/Stops the Program control.								
Monitor mode	By pressing the \odot key for approx. 3 sec in RUN mode, the unit enters Monitor mode. The PV Display indicates PV, and the SV Display indicates MV. Every time the \odot key is pressed, the following is indicated. Indicated contents differ depending on the model.								
	<table border="1"> <thead> <tr> <th>Model</th> <th>Indicated Contents</th> </tr> </thead> <tbody> <tr> <td>BCS2</td> <td>Indicates MV, Remaining time (Program control), Step number (Program control) or Set value memory number (Fixed value control).</td> </tr> <tr> <td>BCR2, BCD2</td> <td>Indicates MV or Remaining time (Program control).</td> </tr> </tbody> </table>	Model	Indicated Contents	BCS2	Indicates MV, Remaining time (Program control), Step number (Program control) or Set value memory number (Fixed value control).	BCR2, BCD2	Indicates MV or Remaining time (Program control).		
	Model	Indicated Contents							
BCS2	Indicates MV, Remaining time (Program control), Step number (Program control) or Set value memory number (Fixed value control).								
BCR2, BCD2	Indicates MV or Remaining time (Program control).								
BCR2, BCD2	Indicates MV or Remaining time (Program control).								
Initial setting mode	By pressing the \surd and \odot keys (in that order) together for approx. 3 sec in RUN mode, the unit enters Initial setting mode. The following items can be set. Input type, Scaling high limit/low limit, Event output EV1/EV2 (EV2, EV2+D \square option) allocation, Event input DI1/DI2 allocation (*), SV1, etc.								
Main setting mode	By pressing the \odot key in RUN mode, the unit enters Main setting mode. SV can be set. If 'Program control' is selected in [OUT/OFF key function], SV, Time and Wait value for Steps 1 to 9 can be set. If 'Set value memory number' is selected in [Event input DI1/DI2 allocation] (*), SV1 to SV4 can be set.								
Sub setting mode	By pressing the \wedge and \odot keys (in that order) together in RUN mode, the unit enters Sub setting mode. The following items can be set. AT Perform, P, I, D, Direct/Reverse action, Event output EV1/EV2 (EV2, EV2+D \square option), etc.								
Engineering mode 1	By pressing the \wedge and \surd keys (in that order) together for approx. 3 sec in RUN mode, the unit enters Engineering mode 1. The following items can be set. Set value lock, Event input DI1/DI2 allocation (*), Event output EV1/EV2 (EV2, EV2+D \square option) allocation, Sensor correction, PV filter time constant, Program control, OUT/OFF key function, Controller/Converter, etc.								
Engineering mode 2	By pressing the \wedge , \surd , \odot keys (in that order) together for approx. 5 sec in RUN mode, the unit enters Engineering mode 2. The following items can be set. Control method, Proportional gain 2DOF coefficient (α), Integral 2DOF coefficient (β)								

(*) Event input DI1 allocation: BCS2 with EIW, EIT, EI options, BCR2/BCD2 with C5W, EIW, EIT, EI options
Event input DI2 allocation: BCS2 with EIW, EI options, BCR2/BCD2 with C5W, EIW, EIT, EI options

5.3 Basic Operation after Power-ON

After the unit is mounted to the control panel and wiring is completed, operate the unit following the procedure below.

(1) Turn the power supply to the unit ON

After the power is turned ON, the PV Display indicates the input type, and the SV Display indicates the Input range high limit value (for thermocouple, RTD inputs) or Scaling high limit value (for DC voltage, current inputs) for approximately 3 seconds. (Table 5.3-1)

During this time, all outputs and the indicators are in OFF status. [0 mA DC for the direct current output type, and 0 mA DC for Transmission output (EIT option)]

Control will then start, indicating the PV on the PV Display and SV on the SV Display.

While the control output OFF function is working, the PV Display indicates [OFF].

Indication differs depending on the selection in [Indication when control output OFF].

(Table 5.3-1)

Sensor Input	°C		°F	
	PV Display	SV Display	PV Display	SV Display
K	600C	1370	600F	2498
	60.C	4000	60.F	7520
J	J00C	1000	J00F	1832
R	r00C	1760	r00F	3200
S	400C	1760	400F	3200
B	600C	1820	600F	3308
E	E00C	0800	E00F	1472
T	r0.C	4000	r0.F	7520
N	r00C	1300	r00F	2372
PL-II	PL2C	1390	PL2F	2534
C(W/Re5-26)	c00C	2315	c00F	4199
Pt100	Pt.C	8500	Pt.F	15620
JPt100	JPt.C	5000	JPt.F	9320
Pt100	Pt0C	0850	Pt0F	1562
JPt100	JPt0C	0500	JPt0F	0932
4 to 20 mA DC	420A	Scaling high limit value		
0 to 20 mA DC	020A			
0 to 1 V DC	001V			
0 to 5 V DC	005V			
1 to 5 V DC	105V			
0 to 10 V DC	010V			

When power is turned ON, and any errors are found, the following error codes are indicated on the PV Display.

To cancel the error code, press the  key.

Error Code	Error Contents
Er01	Non-volatile IC memory is defective.
Er02	Data writing (in non-volatile IC memory) error when power failure occurs.

(2) Enter each value.

Refer to Sections '6. Initial Setting' (p.37) to '8. Operation and Settings of Standard Functions' (p.80):

Enter each value: Input type, Control method, Direct/Reverse action, SV, PID constants, Event output EV1 allocation, etc.

(3) Turn the load circuit power ON

Control starts, so as to reach, and then maintain the control target at the SV.

• Error codes during operation

If errors occur during operation, error codes below are indicated on the PV Display.

Error Code	Error Contents
<i>Er05</i> (*)	PV has exceeded Input range high limit value (scaling high limit value for DC voltage, current inputs).
<i>Er06</i> (*)	PV has dropped below Input range low limit value (scaling low limit value for DC voltage, current inputs).
<i>Er07</i> (*)	Input burnout, or PV has exceeded the Indication range and Control range.
<i>Er10</i>	Hardware malfunction

(*) Indicated when Enabled is selected in [Error indication Enabled/Disabled].

• Indication Range and Control Range

Input Type	Indication Range and Control Range
Thermocouple	[Input range low limit – 50°C (100°F)] to [Input range high limit + 50°C (100°F)]
RTD	[Input range low limit – Input span x 1%] to [Input range high limit + 50°C (100°F)]
DC voltage, Direct current	[Scaling low limit – Scaling span x 1%] to [Scaling high limit + Scaling span x 10%]

• Input error (Overscale, Underscale)

If input errors (overscale, underscale) occur, the following will be performed depending on the selection in [Error indication Enabled/Disabled].

If Disabled is selected in [Error indication Enabled/Disabled]:

Overscale occurs if PV has exceeded Input range high limit value (Scaling high limit value for DC voltage, current inputs). The PV Display indicates PV.

Underscale occurs if PV has dropped below Input range low limit value (Scaling low limit value for DC voltage, current inputs). The PV Display indicates PV.

For manual control, the preset MV is output.

If Enabled is selected in [Error indication Enabled/Disabled]:

Overscale occurs if PV has exceeded Input range high limit value (Scaling high limit value for DC voltage, current inputs). The PV Display indicates PV and error code *Er05* alternately.

Underscale occurs if PV has dropped below Input range low limit value (Scaling low limit value for DC voltage, current inputs). The PV Display indicates PV and error code *Er06* alternately.

For manual control, the preset MV is output.

• **Burnout**

If burnout occurs, the following will be performed depending on the selection in [Error indication Enabled/Disabled].

If Disabled is selected in [Error indication Enabled/Disabled]:

If PV has exceeded Indication range and Control range, the PV Display flashes [- - - -].

If PV has dropped below Indication range and Control range, the PV Display flashes [- - - -].

If thermocouple or RTD input is burnt out, or if DC voltage (0 to 1 V DC) input is disconnected, the PV Display flashes [- - - -].

If DC voltage or current input is disconnected:

For 4 to 20 mA DC, 1 to 5 V DC inputs, the PV Display flashes [- - - -].

For 0 to 20 mA DC, 0 to 5 V DC and 0 to 10 V DC inputs, the PV Display indicates the value corresponding with 0 mA DC or 0 V DC input.

OUT1 and OUT2 are turned OFF (OUT1 low limit value for direct current output, and OUT2 low limit value for DA, EV2+DA).

For manual control, the preset MV is output.

If Alarm, Heater burnout alarm or Loop break alarm is selected in [Event output EV1/EV2 allocation], Event output will be turned ON under the alarm active conditions.

Burnout is enabled even in standby (program control waiting) mode in Program control.

[Output status when input errors occur] can be used only for controllers using direct current and voltage inputs, and direct current output.

Output status differs depending on selection in [Output status when input errors occur].

Output status when input errors occur	Contents, Indication	Output Status			
		OUT1		OUT2	
		Direct (Cooling) action	Reverse (Heating) action	Direct (Cooling) action	Reverse (Heating) action
on []	[- - - -] is flashing.	ON (20mA) or OUT1 high limit value (*)	OFF (4mA) or OUT1 low limit value	OFF or OUT2 low limit value	ON or OUT2 high limit value (*)
off []		OFF (4mA) or OUT1 low limit value			OFF or OUT2 low limit value
on []	[- - - -] is flashing.	OFF (4mA) or OUT1 low limit value	ON (20mA) or OUT1 high limit value (*)	OFF or OUT2 low limit value	OFF or OUT2 low limit value
off []			OFF (4mA) or OUT1 low limit value		

(*) Outputs a value between OFF (4mA) and ON (20mA) or between OUT1 (or OUT2) low limit value and OUT1 (or OUT2) high limit value, depending on deviation.

If Enabled is selected in [Error indication Enabled/Disabled]:

If PV has exceeded Indication range and Control range, the PV Display indicates [- - -] and [E r O 7] alternately.

If PV has dropped below Indication range and Control range, the PV Display indicates [- - -] and [E r O 7] alternately.

If thermocouple or RTD input is burnt out, or if DC voltage (0 to 1 V DC) input is disconnected, the PV Display indicates [- - -] and [E r O 7] alternately.

If DC voltage or current input is disconnected:

For 4 to 20 mA DC, 1 to 5 V DC inputs, the PV Display indicates [- - -] and [E r O 7] alternately.

For 0 to 20 mA DC, 0 to 5 V DC and 0 to 10 V DC inputs, the PV Display indicates the value corresponding with 0 mA DC or 0 V DC input.

OUT1 and OUT2 are turned OFF (OUT1 low limit value for direct current output, and OUT2 low limit value for DA, EV2+DA).

For manual control, the preset MV is output.

If Alarm, Heater burnout alarm or Loop break alarm is selected in [Event output EV1/EV2 allocation], Event output will be turned ON under the alarm active conditions.

Burnout is enabled even in standby (program control waiting) mode in Program control

[Output status when input errors occur] can be used only for controllers using direct current and voltage inputs, and direct current output.

Output status differs depending on selection in [Output status when input errors occur].

Output status when input errors occur	Contents, Indication	Output Status			
		OUT1		OUT2	
		Direct (Cooling) action	Reverse (Heating) action	Direct (Cooling) action	Reverse (Heating) action
on	[- - -] and [E r O 7] are indicated alternately.	ON (20mA) or OUT1 high limit value (*)	OFF (4mA) or OUT1 low limit value	OFF or OUT2 low limit value	ON or OUT2 high limit value (*)
off		OFF (4mA) or OUT1 low limit value			
on	[- - -] and [E r O 7] are indicated alternately.	OFF (4mA) or OUT1 low limit value	ON (20mA) or OUT1 high limit value (*)	OFF or OUT2 low limit value	OFF or OUT2 low limit value
off			OFF (4mA) or OUT1 low limit value		

(*) Outputs a value between OFF (4mA) and ON (20mA) or between OUT1 (or OUT2) low limit value and OUT1 (or OUT2) high limit value, depending on deviation.

6. Initial Setting

Setup (setting the Input type, Event output allocation, SV, etc.) should be done before using this controller, according to the user's conditions.

Perform setup in Initial setting mode.

Setting items in Initial setting mode are shown in (Table 6.1).

If the user's specification is the same as the factory default value of this instrument, or if user's instrument has already been installed in a system, initial settings are not necessary.

Proceed to Section '7. Settings' (p.53).

(Table 6.1)

Setting Items in Initial Setting Mode	Factory Default
Input type	K -200 to 1370°C
Scaling high limit	1370°C
Scaling low limit	-200°C
Decimal point place	No decimal point
Event output EV1 allocation	No event
EV1 alarm value 0 Enabled/Disabled	Disabled
EV1 alarm value	0°C
EV1 high limit alarm value	0°C
EV1 alarm hysteresis	1.0°C
EV1 alarm delay time	0 sec
EV1 alarm Energized/De-energized	Energized
Event output EV2 allocation (EV2, EV2+D□ options)	No event
EV2 alarm value 0 Enabled/Disabled (EV2, EV2+D□ options)	Disabled
EV2 alarm value (EV2, EV2+D□ options)	0°C
EV2 high limit alarm value (EV2, EV2+D□ options)	0°C
EV2 alarm hysteresis (EV2, EV2+D□ options)	1.0°C
EV2 alarm delay time (EV2, EV2+D□ options)	0 sec
EV2 alarm Energized/De-energized (EV2, EV2+D□ options)	Energized
Heater burnout alarm 1 value (C5W, EIW, W options)	0.0 A
Heater burnout alarm 2 value (C5W, EIW, W options)	0.0 A
Loop break alarm time	0 minutes
Loop break alarm span	0°C
Event input DI1 allocation (BCS2: EIW, EIT, EI options, BCR2/BCD2: C5W, EIW, EIT, EI options)	No event
Event input DI2 allocation (BCS2: EIW, EI options, BCR2/BCD2: C5W, EIW, EIT, EI options)	No event
External setting input high limit (EIT option)	1370°C
External setting input low limit (EIT option)	-200°C
Transmission output type (EIT option)	PV transmission
Transmission output high limit (EIT option)	1370°C
Transmission output low limit (EIT option)	-200°C
SV1	0°C
SV2 (BCS2: EIW, EIT, EI options, BCR2/BCD2: C5W, EIW, EIT, EI options)	0°C
SV3 (BCS2: EIW, EI option, BCR2/BCD2: C5W, EIW, EIT, EI options)	0°C
SV4 (BCS2: EIW, EI option, BCR2/BCD2: C5W, EIW, EIT, EI options)	0°C

6.1 Example of Initial Setting

(e.g.) BCS2R00-00

Initial Setting Items	Example
Input type	K -200.0 to 400.0°C
Event output EV1 allocation	High limit alarm
EV1 alarm value	20.0°C (Deviation setting from SV)
SV	200.0°C (Fixed value control)

PID control is performed. PID constants are calculated by performing AT.

Alarm action

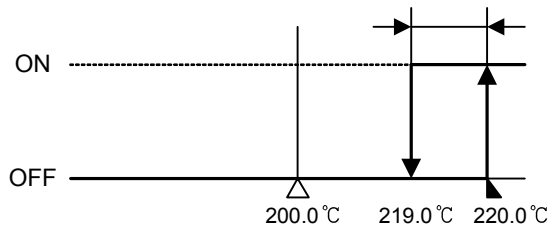

(Fig. 6.1-1)

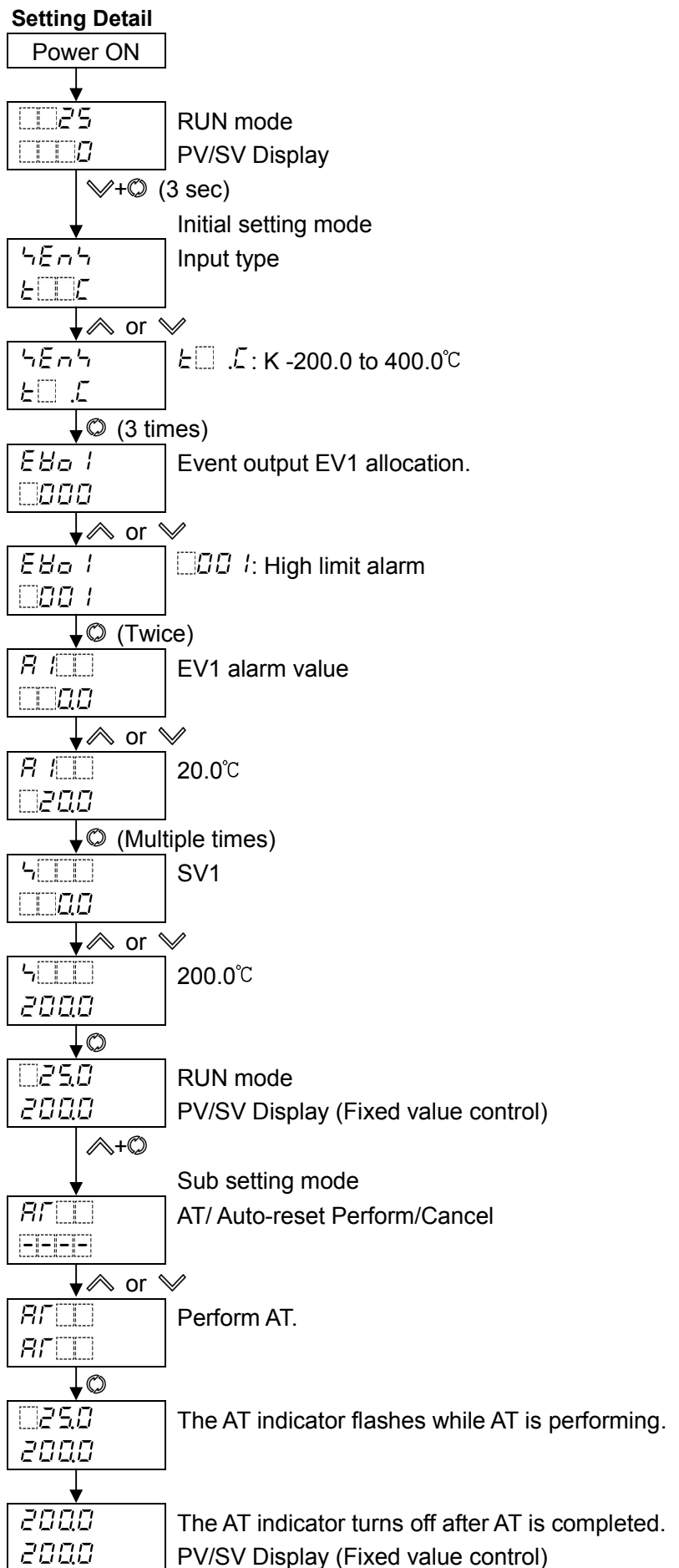
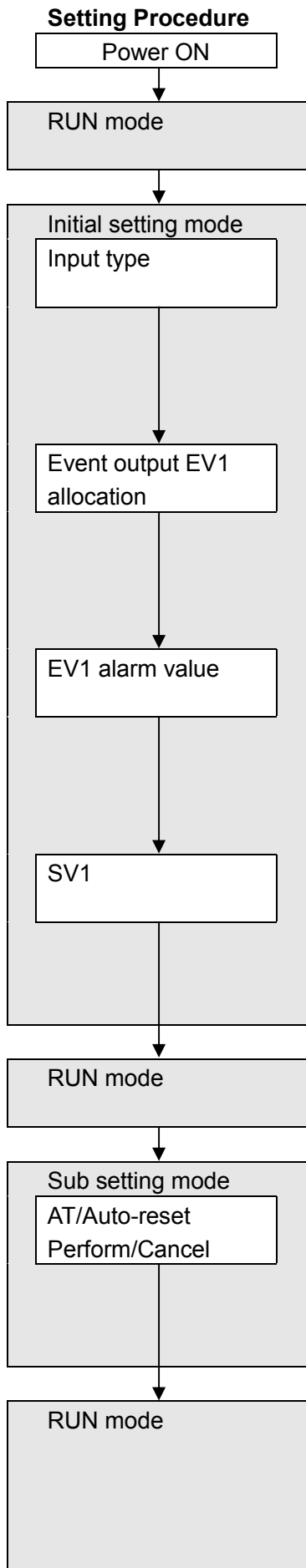

6.2 Initial Setting Mode

To enter Initial setting mode, press and hold the \checkmark and \odot keys (in that order) for 3 seconds in RUN mode.

To set (or select) each setting item, use the \wedge or \vee key.

To register each setting item, press the \odot key.

Explanation of setting item:

- Upper left: PV Display: Indicates setting characters.
- Lower left: SV Display: Indicates factory default value.
- Right side: Indicates the setting item, explanation of its function, and setting range (or selection item).

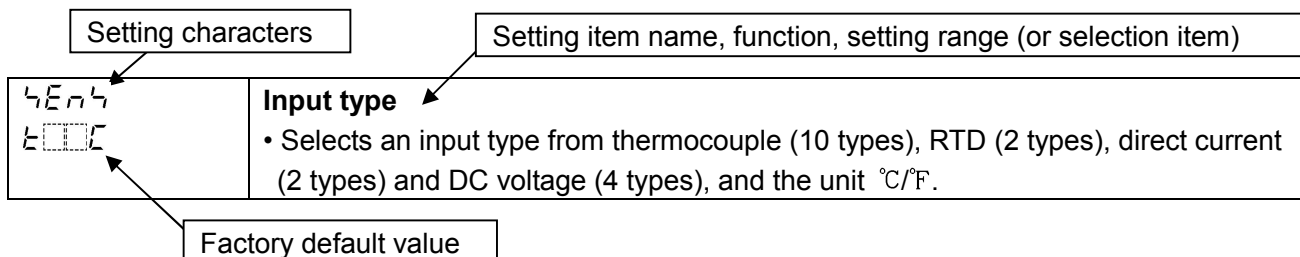

Characters, Factory Default	Setting Item, Function, Setting Range			
4En4 t00C	Input type <ul style="list-style-type: none"> • Selects an input type from thermocouple (10 types), RTD (2 types), direct current (2 types) and DC voltage (4 type), and the unit °C/°F. • When changing the input from DC voltage to other inputs, remove the sensor connected to this controller first, then change the input. If the input is changed with the sensor connected, the input circuit may break. • When changing an input type, refer to Section “8.10 Items to be Initialized by Changing Settings” (p.98). • Selection item: 			
t00C	K	-200 to 1370°C	t00F	K -328 to 2498°F
t0 .C	K	-200.0 to 400.0°C	t0 .F	K -328.0 to 752.0°F
j00C	J	-200 to 1000°C	j00F	J -328 to 1832°F
r00C	R	0 to 1760°C	r00F	R 32 to 3200°F
400C	S	0 to 1760°C	400F	S 32 to 3200°F
b00C	B	0 to 1820°C	b00F	B 32 to 3308°F
E00C	E	-200 to 800°C	E00F	E -328 to 1472°F
r0 .C	T	-200.0 to 400.0°C	r0 .F	T -328.0 to 752.0°F
n00C	N	-200 to 1300°C	n00F	N -328 to 2372°F
PL2C	PL-II	0 to 1390°C	PL2F	PL-II 32 to 2534°F
c00C	C(W/Re5-26)	0 to 2315°C	c00F	C(W/Re5-26) 32 to 4199°F
Pt .C	Pt100	-200.0 to 850.0°C	Pt .F	Pt100 -328.0 to 1562.0°F
JPt .C	JPt100	-200.0 to 500.0°C	JPt .F	JPt100 -328.0 to 932.0°F
Pt0C	Pt100	-200 to 850°C	Pt0F	Pt100 -328 to 1562°F
JPt0C	JPt100	-200 to 500°C	JPt0F	JPt100 -328 to 932°F
420A	4 to 20 mA DC	-2000 to 10000		
020A	0 to 20 mA DC	-2000 to 10000		
001V	0 to 1 V DC	-2000 to 10000		
005V	0 to 5 V DC	-2000 to 10000		
105V	1 to 5 V DC	-2000 to 10000		
010V	0 to 10 V DC	-2000 to 10000		
4FLH 1370	Scaling high limit <ul style="list-style-type: none"> • Sets scaling high limit value. • Setting range: Scaling low limit value to Input range high limit value DC voltage, current inputs: -2000 to 10000 (*1) 			

(*1) The placement of the decimal point follows the selection.

Characters, Factory Default	Setting Item, Function, Setting Range																																																													
4LLL -200	Scaling low limit • Sets scaling low limit value. • Setting range: Input range low limit value to Scaling high limit value DC voltage, current inputs: -2000 to 10000 (*1)																																																													
dP□□ □□□□	Decimal point place • Selects decimal point place. • Selection item: <table border="1" data-bbox="422 392 1476 555"> <tr> <td>□□□□</td> <td>No decimal point</td> </tr> <tr> <td>□□□□</td> <td>1 digit after decimal point</td> </tr> <tr> <td>□□□□</td> <td>2 digits after decimal point</td> </tr> <tr> <td>□□□□</td> <td>3 digits after decimal point</td> </tr> </table>		□□□□	No decimal point	□□□□	1 digit after decimal point	□□□□	2 digits after decimal point	□□□□	3 digits after decimal point																																																				
□□□□	No decimal point																																																													
□□□□	1 digit after decimal point																																																													
□□□□	2 digits after decimal point																																																													
□□□□	3 digits after decimal point																																																													
Available only for DC voltage and current inputs																																																														
EV0 1 □□□□	Event output EV1 allocation • Selects Event output EV1 from the Event Output Allocation Table below. • When changing Event output EV1, refer to Section “8.10 Items to be Initialized by Changing Settings” (p.98). • Selection item: <table border="1" data-bbox="422 788 1476 2096"> <thead> <tr> <th colspan="3">Event Output Allocation Table</th> </tr> </thead> <tbody> <tr> <td>□□□□</td> <td>No event</td> <td></td> </tr> <tr> <td>□□□ 1</td> <td>Alarm output, High limit alarm</td> <td></td> </tr> <tr> <td>□□□ 2</td> <td>Alarm output, Low limit alarm</td> <td></td> </tr> <tr> <td>□□□ 3</td> <td>Alarm output, High/Low limits alarm</td> <td></td> </tr> <tr> <td>□□□ 4</td> <td>Alarm output, High/Low limits independent alarm</td> <td></td> </tr> <tr> <td>□□□ 5</td> <td>Alarm output, High/Low limit range alarm</td> <td></td> </tr> <tr> <td>□□□ 6</td> <td>Alarm output, High/Low limit range independent alarm</td> <td></td> </tr> <tr> <td>□□□ 7</td> <td>Alarm output, Process high alarm</td> <td></td> </tr> <tr> <td>□□□ 8</td> <td>Alarm output, Process low alarm</td> <td></td> </tr> <tr> <td>□□□ 9</td> <td>Alarm output, High limit with standby alarm</td> <td></td> </tr> <tr> <td>□□ 10</td> <td>Alarm output, Low limit with standby alarm</td> <td></td> </tr> <tr> <td>□□ 11</td> <td>Alarm output, High/Low limits with standby alarm</td> <td></td> </tr> <tr> <td>□□ 12</td> <td>Alarm output, High/Low limits with standby independent alarm</td> <td></td> </tr> <tr> <td>□□ 13</td> <td>Heater burnout alarm output</td> <td></td> </tr> <tr> <td>□□ 14</td> <td>Loop break alarm output</td> <td></td> </tr> <tr> <td>□□ 15</td> <td>Time signal output</td> <td>Turns OFF or ON during Program control, by setting OFF and ON time within the step set in [Step number].</td> </tr> <tr> <td>□□ 16</td> <td>Output during AT</td> <td>Turns ON during AT.</td> </tr> <tr> <td>□□ 17</td> <td>Pattern end output</td> <td>Turns ON when Program control ends, and remains ON until turned OFF by pressing the © key.</td> </tr> <tr> <td>□□ 18</td> <td>Output by communication command</td> <td>Turns OFF or ON by communication command 00E4H during Serial communication. B0 EV1 output 0: OFF 1: ON B1 EV2 output 0: OFF 1: ON</td> </tr> </tbody> </table>		Event Output Allocation Table			□□□□	No event		□□□ 1	Alarm output, High limit alarm		□□□ 2	Alarm output, Low limit alarm		□□□ 3	Alarm output, High/Low limits alarm		□□□ 4	Alarm output, High/Low limits independent alarm		□□□ 5	Alarm output, High/Low limit range alarm		□□□ 6	Alarm output, High/Low limit range independent alarm		□□□ 7	Alarm output, Process high alarm		□□□ 8	Alarm output, Process low alarm		□□□ 9	Alarm output, High limit with standby alarm		□□ 10	Alarm output, Low limit with standby alarm		□□ 11	Alarm output, High/Low limits with standby alarm		□□ 12	Alarm output, High/Low limits with standby independent alarm		□□ 13	Heater burnout alarm output		□□ 14	Loop break alarm output		□□ 15	Time signal output	Turns OFF or ON during Program control, by setting OFF and ON time within the step set in [Step number].	□□ 16	Output during AT	Turns ON during AT.	□□ 17	Pattern end output	Turns ON when Program control ends, and remains ON until turned OFF by pressing the © key.	□□ 18	Output by communication command	Turns OFF or ON by communication command 00E4H during Serial communication. B0 EV1 output 0: OFF 1: ON B1 EV2 output 0: OFF 1: ON
Event Output Allocation Table																																																														
□□□□	No event																																																													
□□□ 1	Alarm output, High limit alarm																																																													
□□□ 2	Alarm output, Low limit alarm																																																													
□□□ 3	Alarm output, High/Low limits alarm																																																													
□□□ 4	Alarm output, High/Low limits independent alarm																																																													
□□□ 5	Alarm output, High/Low limit range alarm																																																													
□□□ 6	Alarm output, High/Low limit range independent alarm																																																													
□□□ 7	Alarm output, Process high alarm																																																													
□□□ 8	Alarm output, Process low alarm																																																													
□□□ 9	Alarm output, High limit with standby alarm																																																													
□□ 10	Alarm output, Low limit with standby alarm																																																													
□□ 11	Alarm output, High/Low limits with standby alarm																																																													
□□ 12	Alarm output, High/Low limits with standby independent alarm																																																													
□□ 13	Heater burnout alarm output																																																													
□□ 14	Loop break alarm output																																																													
□□ 15	Time signal output	Turns OFF or ON during Program control, by setting OFF and ON time within the step set in [Step number].																																																												
□□ 16	Output during AT	Turns ON during AT.																																																												
□□ 17	Pattern end output	Turns ON when Program control ends, and remains ON until turned OFF by pressing the © key.																																																												
□□ 18	Output by communication command	Turns OFF or ON by communication command 00E4H during Serial communication. B0 EV1 output 0: OFF 1: ON B1 EV2 output 0: OFF 1: ON																																																												

(*1) The placement of the decimal point follows the selection.

Characters, Factory Default	Setting Item, Function, Setting Range																								
R 12A no□□	<p>EV1 alarm value 0 Enabled/Disabled</p> <ul style="list-style-type: none"> When EV1 alarm value is 0 (zero), alarm action can be Enabled or Disabled. Selection item: <table border="1" style="width: 100%; border-collapse: collapse;"> <tr> <td style="width: 30%; text-align: center;">no□□</td> <td style="text-align: center;">Disabled</td> </tr> <tr> <td style="text-align: center;">yE4□</td> <td style="text-align: center;">Enabled</td> </tr> </table> <p>Available when □□□ 1 (Alarm output, High limit alarm) to □□□5 (Alarm output, High/Low limit range independent alarm), □□□9 (Alarm output, High limit with standby alarm) to □□ 12 (Alarm output, High/Low limits with standby independent alarm) are selected in [Event output EV1 allocation].</p>	no□□	Disabled	yE4□	Enabled																				
no□□	Disabled																								
yE4□	Enabled																								
R 1□□ □□□□	<p>EV1 alarm value</p> <ul style="list-style-type: none"> Sets EV1 alarm value. EV1 alarm value matches EV1 low limit alarm value in the following cases: <ul style="list-style-type: none"> □□□4 (Alarm output, High/Low limits independent alarm), □□□5 (Alarm output, High/Low limit range independent alarm), or □□ 12 (Alarm output, High/Low limits with standby independent alarm) is selected in [Event output EV1 allocation]. Setting range: <table border="1" style="width: 100%; border-collapse: collapse;"> <tr> <td style="width: 50%;">High limit alarm</td> <td>-(Input span) to Input span °C (°F) (*1) (*2)</td> </tr> <tr> <td>Low limit alarm</td> <td>-(Input span) to Input span °C (°F) (*1) (*2)</td> </tr> <tr> <td>High/Low limits alarm</td> <td>0 to Input span °C (°F) (*1) (*2)</td> </tr> <tr> <td>High/Low limits independent alarm</td> <td>0 to Input span °C (°F) (*1) (*2)</td> </tr> <tr> <td>High/Low limit range alarm</td> <td>0 to Input span °C (°F) (*1) (*2)</td> </tr> <tr> <td>High/Low limit range independent alarm</td> <td>0 to Input span °C (°F) (*1) (*2)</td> </tr> <tr> <td>Process high alarm</td> <td>Input range low limit to Input range high limit (*1) (*3)</td> </tr> <tr> <td>Process low alarm</td> <td>Input range low limit to Input range high limit (*1) (*3)</td> </tr> <tr> <td>High limit with standby alarm</td> <td>-(Input span) to Input span °C (°F) (*1) (*2)</td> </tr> <tr> <td>Low limit with standby alarm</td> <td>-(Input span) to Input span °C (°F) (*1) (*2)</td> </tr> <tr> <td>High/Low limits with standby alarm</td> <td>0 to Input span °C (°F) (*1) (*2)</td> </tr> <tr> <td>High/Low limits with standby independent alarm</td> <td>0 to Input span °C (°F) (*1) (*2)</td> </tr> </table> <p>Available when any alarm from □□□ 1 (Alarm output, High limit alarm) to □□ 12 (Alarm output, High/Low limits with standby independent alarm) is selected in [Event output EV1 allocation].</p>	High limit alarm	-(Input span) to Input span °C (°F) (*1) (*2)	Low limit alarm	-(Input span) to Input span °C (°F) (*1) (*2)	High/Low limits alarm	0 to Input span °C (°F) (*1) (*2)	High/Low limits independent alarm	0 to Input span °C (°F) (*1) (*2)	High/Low limit range alarm	0 to Input span °C (°F) (*1) (*2)	High/Low limit range independent alarm	0 to Input span °C (°F) (*1) (*2)	Process high alarm	Input range low limit to Input range high limit (*1) (*3)	Process low alarm	Input range low limit to Input range high limit (*1) (*3)	High limit with standby alarm	-(Input span) to Input span °C (°F) (*1) (*2)	Low limit with standby alarm	-(Input span) to Input span °C (°F) (*1) (*2)	High/Low limits with standby alarm	0 to Input span °C (°F) (*1) (*2)	High/Low limits with standby independent alarm	0 to Input span °C (°F) (*1) (*2)
High limit alarm	-(Input span) to Input span °C (°F) (*1) (*2)																								
Low limit alarm	-(Input span) to Input span °C (°F) (*1) (*2)																								
High/Low limits alarm	0 to Input span °C (°F) (*1) (*2)																								
High/Low limits independent alarm	0 to Input span °C (°F) (*1) (*2)																								
High/Low limit range alarm	0 to Input span °C (°F) (*1) (*2)																								
High/Low limit range independent alarm	0 to Input span °C (°F) (*1) (*2)																								
Process high alarm	Input range low limit to Input range high limit (*1) (*3)																								
Process low alarm	Input range low limit to Input range high limit (*1) (*3)																								
High limit with standby alarm	-(Input span) to Input span °C (°F) (*1) (*2)																								
Low limit with standby alarm	-(Input span) to Input span °C (°F) (*1) (*2)																								
High/Low limits with standby alarm	0 to Input span °C (°F) (*1) (*2)																								
High/Low limits with standby independent alarm	0 to Input span °C (°F) (*1) (*2)																								
R 1H□ □□□□	<p>EV1 high limit alarm value</p> <ul style="list-style-type: none"> Sets EV1 high limit alarm value. This value is available only for the following. <ul style="list-style-type: none"> □□□4 (Alarm output, High/Low limits independent alarm), □□□5 (Alarm output, High/Low limit range independent alarm), or □□ 12 (Alarm output, High/Low limits with standby independent alarm) is selected in [Event output EV1 allocation]. Setting range: Same as those of EV1 alarm value 																								

(*1) The placement of the decimal point follows the selection.

(*2) For DC voltage, current inputs, the input span is the same as the scaling span.

(*3) For DC voltage, current inputs, input range low (or high) limit value is the same as scaling low (or high) limit value.

Characters, Factory Default	Setting Item, Function, Setting Range				
R 1H4 00 10	<p>EV1 alarm hysteresis</p> <ul style="list-style-type: none"> Sets EV1 alarm hysteresis. Setting range: 0.1 to 1000.0°C (°F), DC voltage, current inputs: 1 to 10000 (*1) <p>Available when any alarm from 000 1 (Alarm output, High limit alarm) to 00 12 (Alarm output, High/Low limits with standby independent alarm) is selected in [Event output EV1 allocation].</p>				
R 124 0000	<p>EV1 alarm delay time</p> <ul style="list-style-type: none"> Sets EV1 alarm action delay time. <p>When setting time has elapsed after the input enters the alarm output range, the alarm is activated.</p> <ul style="list-style-type: none"> Setting range: 0 to 10000 seconds <p>Available when any alarm from 000 1 (Alarm output, High limit alarm) to 00 12 (Alarm output, High/Low limits with standby independent alarm) is selected in [Event output EV1 allocation].</p>				
R 1L̄ nōL̄	<p>EV1 alarm Energized/De-energized</p> <ul style="list-style-type: none"> Selects Energized/De-energized status for EV1 alarm. (Refer to 'EV1/EV2 Energized/De-energized' on p.50.) Selection item: <table border="1" style="width: 100%; border-collapse: collapse;"> <tr> <td style="text-align: center;">nōL̄</td> <td style="text-align: center;">Energized</td> </tr> <tr> <td style="text-align: center;">rĒL̄</td> <td style="text-align: center;">De-energized</td> </tr> </table> <p>Available when any alarm from 000 1 (Alarm output, High limit alarm) to 00 12 (Alarm output, High/Low limits with standby independent alarm) is selected in [Event output EV1 allocation].</p>	nōL̄	Energized	rĒL̄	De-energized
nōL̄	Energized				
rĒL̄	De-energized				
F4 14 00 1	<p>TS1 output step number</p> <ul style="list-style-type: none"> Sets the step number at which Time signal output TS1 will be turned OFF or ON during Program control. (Refer to 'Time Signal Output' on p.52.) Setting range: 1 to 9 <p>Available only when 00 15 (Time signal output) is selected in [Event output EV1 allocation].</p>				
F4 1F 0000	<p>TS1 OFF time</p> <ul style="list-style-type: none"> Sets Time signal output TS1 OFF time. (Refer to 'Time Signal Output' on p.52.) Setting range: 00:00 to 99:59 (*2) <p>Available only when 00 15 (Time signal output) is selected in [Event output EV1 allocation].</p>				
F4 1o 0000	<p>TS1 ON time</p> <ul style="list-style-type: none"> Sets Time signal output TS1 ON time. (Refer to 'Time Signal Output' on p.52.) Setting range: 00:00 to 99:59 (*2) <p>Available only when 00 15 (Time signal output) is selected in [Event output EV1 allocation].</p>				

(*1) The placement of the decimal point follows the selection.

(*2) Time unit follows the selection in [Step time unit].

Characters, Factory Default	Setting Item, Function, Setting Range																																																													
E802 000	<p>Event output EV2 allocation</p> <ul style="list-style-type: none"> • Selects Event output EV2 from the Event Output Allocation Table below. • When changing Event output EV2, refer to Section “8.10 Items to be Initialized by Changing Settings” (p.98). • Selection item: <p>Event Output Allocation Table</p> <table border="1" data-bbox="422 376 1471 1729"> <tr> <td>000</td> <td>No event</td> <td></td> </tr> <tr> <td>001</td> <td>Alarm output, High limit alarm</td> <td></td> </tr> <tr> <td>002</td> <td>Alarm output, Low limit alarm</td> <td></td> </tr> <tr> <td>003</td> <td>Alarm output, High/Low limits alarm</td> <td></td> </tr> <tr> <td>004</td> <td>Alarm output, High/Low limits independent alarm</td> <td></td> </tr> <tr> <td>005</td> <td>Alarm output, High/Low limit range alarm</td> <td></td> </tr> <tr> <td>006</td> <td>Alarm output, High/Low limit range independent alarm</td> <td></td> </tr> <tr> <td>007</td> <td>Alarm output, Process high alarm</td> <td></td> </tr> <tr> <td>008</td> <td>Alarm output, Process low alarm</td> <td></td> </tr> <tr> <td>009</td> <td>Alarm output, High limit with standby alarm</td> <td></td> </tr> <tr> <td>010</td> <td>Alarm output, Low limit with standby alarm</td> <td></td> </tr> <tr> <td>011</td> <td>Alarm output, High/Low limits with standby alarm</td> <td></td> </tr> <tr> <td>012</td> <td>Alarm output, High/Low limits with standby independent alarm</td> <td></td> </tr> <tr> <td>013</td> <td>Heater burnout alarm output</td> <td></td> </tr> <tr> <td>014</td> <td>Loop break alarm output</td> <td></td> </tr> <tr> <td>015</td> <td>Time signal output</td> <td>Turns OFF or ON during Program control, by setting OFF and ON times within the step set in [Step number].</td> </tr> <tr> <td>016</td> <td>Output during AT</td> <td>Turns ON during AT.</td> </tr> <tr> <td>017</td> <td>Pattern end output</td> <td>Turns ON when Program control ends, and remains ON until turned OFF by pressing the © key.</td> </tr> <tr> <td>018</td> <td>Output by communication command</td> <td>Turns OFF or ON by communication command 00E4H during Serial communication. B0 EV1 output 0: OFF 1: ON B1 EV2 output 0: OFF 1: ON</td> </tr> <tr> <td>019</td> <td>Heating/Cooling control relay contact output</td> <td>Works as Control output OUT2 (Heating/Cooling control).</td> </tr> </table> <p>Available only when Event output EV2 (EV2, EV2+D□ options) is ordered.</p>		000	No event		001	Alarm output, High limit alarm		002	Alarm output, Low limit alarm		003	Alarm output, High/Low limits alarm		004	Alarm output, High/Low limits independent alarm		005	Alarm output, High/Low limit range alarm		006	Alarm output, High/Low limit range independent alarm		007	Alarm output, Process high alarm		008	Alarm output, Process low alarm		009	Alarm output, High limit with standby alarm		010	Alarm output, Low limit with standby alarm		011	Alarm output, High/Low limits with standby alarm		012	Alarm output, High/Low limits with standby independent alarm		013	Heater burnout alarm output		014	Loop break alarm output		015	Time signal output	Turns OFF or ON during Program control, by setting OFF and ON times within the step set in [Step number].	016	Output during AT	Turns ON during AT.	017	Pattern end output	Turns ON when Program control ends, and remains ON until turned OFF by pressing the © key.	018	Output by communication command	Turns OFF or ON by communication command 00E4H during Serial communication. B0 EV1 output 0: OFF 1: ON B1 EV2 output 0: OFF 1: ON	019	Heating/Cooling control relay contact output	Works as Control output OUT2 (Heating/Cooling control).
000	No event																																																													
001	Alarm output, High limit alarm																																																													
002	Alarm output, Low limit alarm																																																													
003	Alarm output, High/Low limits alarm																																																													
004	Alarm output, High/Low limits independent alarm																																																													
005	Alarm output, High/Low limit range alarm																																																													
006	Alarm output, High/Low limit range independent alarm																																																													
007	Alarm output, Process high alarm																																																													
008	Alarm output, Process low alarm																																																													
009	Alarm output, High limit with standby alarm																																																													
010	Alarm output, Low limit with standby alarm																																																													
011	Alarm output, High/Low limits with standby alarm																																																													
012	Alarm output, High/Low limits with standby independent alarm																																																													
013	Heater burnout alarm output																																																													
014	Loop break alarm output																																																													
015	Time signal output	Turns OFF or ON during Program control, by setting OFF and ON times within the step set in [Step number].																																																												
016	Output during AT	Turns ON during AT.																																																												
017	Pattern end output	Turns ON when Program control ends, and remains ON until turned OFF by pressing the © key.																																																												
018	Output by communication command	Turns OFF or ON by communication command 00E4H during Serial communication. B0 EV1 output 0: OFF 1: ON B1 EV2 output 0: OFF 1: ON																																																												
019	Heating/Cooling control relay contact output	Works as Control output OUT2 (Heating/Cooling control).																																																												
A23A no□	<p>EV2 alarm value 0 Enabled/Disabled</p> <ul style="list-style-type: none"> • When EV2 alarm value is 0 (zero), alarm action can be Enabled or Disabled. • Selection item: <table border="1" data-bbox="422 1886 1471 1966"> <tr> <td>no□</td> <td>Disabled</td> </tr> <tr> <td>4E4□</td> <td>Enabled</td> </tr> </table> <p>Available only when Event output EV2 (EV2, EV2+D□ options) is ordered. Available when 001 (Alarm output, High limit alarm) to 005 (Alarm output, High/Low limit range independent alarm), 009 (Alarm output, High limit with standby alarm) to 012 (Alarm output, High/Low limits with standby independent alarm) are selected in [Event output EV2 allocation].</p>		no□	Disabled	4E4□	Enabled																																																								
no□	Disabled																																																													
4E4□	Enabled																																																													

(*1) Not available if Heating/Cooling control (EV2+D□ option) is ordered.

Characters, Factory Default	Setting Item, Function, Setting Range																								
R2□□ □□□□	<p>EV2 alarm value</p> <ul style="list-style-type: none"> Sets EV2 alarm value. <p>EV2 alarm value matches EV2 low limit alarm value in the following cases: □□□□ (Alarm output, High/Low limits independent alarm), □□□□ (Alarm output, High/Low limit range independent alarm), or □□□□ (Alarm output, High/Low limits with standby independent alarm) is selected in [Event output EV2 allocation].</p> <ul style="list-style-type: none"> Setting range: <table border="1" data-bbox="424 427 1473 1039"> <tr> <td>High limit alarm</td> <td>-(Input span) to Input span °C (°F) (*1) (*2)</td> </tr> <tr> <td>Low limit alarm</td> <td>-(Input span) to Input span °C (°F) (*1) (*2)</td> </tr> <tr> <td>High/Low limits alarm</td> <td>0 to Input span °C (°F) (*1) (*2)</td> </tr> <tr> <td>High/Low limits independent alarm</td> <td>0 to Input span °C (°F) (*1) (*2)</td> </tr> <tr> <td>High/Low limit range alarm</td> <td>0 to Input span °C (°F) (*1) (*2)</td> </tr> <tr> <td>High/Low limit range independent alarm</td> <td>0 to Input span °C (°F) (*1) (*2)</td> </tr> <tr> <td>Process high alarm</td> <td>Input range low limit to Input range high limit (*1) (*3)</td> </tr> <tr> <td>Process low alarm</td> <td>Input range low limit to Input range high limit (*1) (*3)</td> </tr> <tr> <td>High limit with standby alarm</td> <td>-(Input span) to Input span °C (°F) (*1) (*2)</td> </tr> <tr> <td>Low limit with standby alarm</td> <td>-(Input span) to Input span °C (°F) (*1) (*2)</td> </tr> <tr> <td>High/Low limits with standby</td> <td>0 to Input span °C (°F) (*1) (*2)</td> </tr> <tr> <td>High/Low limits with standby independent alarm</td> <td>0 to Input span °C (°F) (*1) (*2)</td> </tr> </table> <p>Available only when Event output EV2 (EV2, EV2+D□ options) is ordered. Available when any alarm from □□□□ (Alarm output, High limit alarm) to □□□□ (Alarm output, High/Low limits with standby independent alarm) is selected in [Event output EV2 allocation].</p>	High limit alarm	-(Input span) to Input span °C (°F) (*1) (*2)	Low limit alarm	-(Input span) to Input span °C (°F) (*1) (*2)	High/Low limits alarm	0 to Input span °C (°F) (*1) (*2)	High/Low limits independent alarm	0 to Input span °C (°F) (*1) (*2)	High/Low limit range alarm	0 to Input span °C (°F) (*1) (*2)	High/Low limit range independent alarm	0 to Input span °C (°F) (*1) (*2)	Process high alarm	Input range low limit to Input range high limit (*1) (*3)	Process low alarm	Input range low limit to Input range high limit (*1) (*3)	High limit with standby alarm	-(Input span) to Input span °C (°F) (*1) (*2)	Low limit with standby alarm	-(Input span) to Input span °C (°F) (*1) (*2)	High/Low limits with standby	0 to Input span °C (°F) (*1) (*2)	High/Low limits with standby independent alarm	0 to Input span °C (°F) (*1) (*2)
High limit alarm	-(Input span) to Input span °C (°F) (*1) (*2)																								
Low limit alarm	-(Input span) to Input span °C (°F) (*1) (*2)																								
High/Low limits alarm	0 to Input span °C (°F) (*1) (*2)																								
High/Low limits independent alarm	0 to Input span °C (°F) (*1) (*2)																								
High/Low limit range alarm	0 to Input span °C (°F) (*1) (*2)																								
High/Low limit range independent alarm	0 to Input span °C (°F) (*1) (*2)																								
Process high alarm	Input range low limit to Input range high limit (*1) (*3)																								
Process low alarm	Input range low limit to Input range high limit (*1) (*3)																								
High limit with standby alarm	-(Input span) to Input span °C (°F) (*1) (*2)																								
Low limit with standby alarm	-(Input span) to Input span °C (°F) (*1) (*2)																								
High/Low limits with standby	0 to Input span °C (°F) (*1) (*2)																								
High/Low limits with standby independent alarm	0 to Input span °C (°F) (*1) (*2)																								
R2H□ □□□□	<p>EV2 high limit alarm value</p> <ul style="list-style-type: none"> Sets EV2 high limit alarm value. <p>This value is available only for the following: □□□□ (Alarm output, High/Low limits independent alarm), □□□□ (Alarm output, High/Low limit range independent alarm), or □□□□ (Alarm output, High/Low limits with standby independent alarm) is selected in [Event output EV2 allocation].</p> <ul style="list-style-type: none"> Setting range: Same as those of EV2 alarm value <p>Available only when Event output EV2 (EV2, EV2+D□ options) is ordered.</p>																								
R2HY □□.□□	<p>EV2 alarm hysteresis</p> <ul style="list-style-type: none"> Sets EV2 alarm hysteresis. <ul style="list-style-type: none"> Setting range: 0.1 to 1000.0°C (°F), DC voltage, current inputs: 1 to 10000 (*1) <p>Available only when Event output EV2 (EV2, EV2+D□ options) is ordered. Available when any alarm from □□□□ (Alarm output, High limit alarm) to □□□□ (Alarm output, High/Low limits with standby independent alarm) is selected in [Event output EV2 allocation].</p>																								
R2dY □□□□	<p>EV2 alarm delay time</p> <ul style="list-style-type: none"> Sets EV2 alarm action delay time. <p>When setting time has elapsed after the input enters the alarm output range, the alarm is activated.</p> <ul style="list-style-type: none"> Setting range: 0 to 10000 seconds <p>Available only when Event output EV2 (EV2, EV2+D□ options) is ordered. Available when any alarm from □□□□ (Alarm output, High limit alarm) to □□□□ (Alarm output, High/Low limits with standby independent alarm) is selected in [Event output EV2 allocation].</p>																								

(*1) The placement of the decimal point follows the selection.

(*2) For DC voltage, current inputs, the input span is the same as the scaling span.

(*3) For DC voltage, current inputs, input range low (or high) limit value is the same as scaling low (or high) limit value.

Characters, Factory Default	Setting Item, Function, Setting Range				
A2L [~] no [~] L	<p>EV2 alarm Energized/De-energized</p> <ul style="list-style-type: none"> • Selects Energized/De-energized status for EV2 alarm. (Refer to 'EV1/EV2 Energized/De-energized' on p.50.) • Selection item: <table border="1" data-bbox="437 338 756 416"> <tr> <td data-bbox="437 338 564 376">no[~]L</td> <td data-bbox="569 338 756 376">Energized</td> </tr> <tr> <td data-bbox="437 378 564 416">rE[~]L</td> <td data-bbox="569 378 756 416">De-energized</td> </tr> </table> <p>Available only when Event output EV2 (EV2, EV2+D□ options) is ordered. Available when any alarm from □□□ 1 (Alarm output, High limit alarm) to □□ 12 (Alarm output, High/Low limits with standby independent alarm) is selected in [Event output EV2 allocation].</p>	no [~] L	Energized	rE [~] L	De-energized
no [~] L	Energized				
rE [~] L	De-energized				
r424 □□□ 1	<p>TS2 output step number</p> <ul style="list-style-type: none"> • Sets the step number at which Time signal output TS2 will be turned OFF or ON during Program control. (Refer to 'Time Signal Output' on p.52.) • Setting range: 1 to 9 <p>Available only when □□ 15 (Time signal output) is selected in [Event output EV2 allocation].</p>				
r42F 0000	<p>TS2 OFF time</p> <ul style="list-style-type: none"> • Sets Time signal output TS2 OFF time. (Refer to 'Time Signal Output' on p.52.) • Setting range: 00:00 to 99:59 (*1) <p>Available only when □□ 15 (Time signal output) is selected in [Event output EV2 allocation].</p>				
r42o 0000	<p>TS2 ON time</p> <ul style="list-style-type: none"> • Sets Time signal output TS2 ON time. (Refer to 'Time Signal Output' on p.52.) • Setting range: 00:00 to 99:59 (*1) <p>Available only when □□ 15 (Time signal output) is selected in [Event output EV2 allocation].</p>				
H 1 □ □□□□ H 1 and CT1 current value are alternately indicated on the PV Display.	<p>Heater burnout alarm 1 value</p> <ul style="list-style-type: none"> • Sets the heater current value for Heater burnout alarm 1. Characters H 1 and CT1 current value are alternately indicated on the PV Display. When OUT1 is ON, the CT1 current value is updated. When OUT1 is OFF, the unit memorizes the previous value when OUT1 was ON. Upon returning to set limits, the alarm will stop. • Setting range: 20 A: 0.0 to 20.0 A 100 A: 0.0 to 100.0 A Setting to 0.0 disables the alarm. <p>Not available for the direct current output type. Available when Heater burnout alarm (C5W, EIW, W options) is ordered.</p>				

(*1) Time unit follows the selection in [Step time unit].

Characters, Factory Default	Setting Item, Function, Setting Range																																								
H2 00 0000 H2 and CT2 current value are alternately indicated on the PV Display.	<p>Heater burnout alarm 2 value</p> <ul style="list-style-type: none"> Sets the heater current value for Heater burnout alarm 2. Available only when using 3-phase. Characters H2 and CT2 current value are alternately indicated on the PV Display. When OUT1 is ON, the CT2 current value is updated. When OUT1 is OFF, the unit memorizes the previous value when OUT1 was ON. Upon returning to set limits, the alarm will stop. Setting range: 20 A: 0.0 to 20.0 A 100 A: 0.0 to 100.0 A Setting to 0.0 disables the alarm. <p>Not available for the direct current output type. Available only when Heater burnout alarm (C5W, EIW, W options) is ordered.</p>																																								
LP_F 0000	<p>Loop break alarm time</p> <ul style="list-style-type: none"> Sets the time to assess the Loop break alarm. Refer to 'Loop Break Alarm' on p.50. Setting range: 0 to 200 minutes Setting to 0 (zero) disables the alarm. 																																								
LP_H 0000	<p>Loop break alarm span</p> <ul style="list-style-type: none"> Sets the temperature to assess the Loop break alarm. Refer to 'Loop Break Alarm' on p.50. Setting range: 0 to 150°C (°F), or 0.0 to 150.0°C (°F) DC voltage, current inputs: 0 to 1500 (*1) Setting to 0 (zero) disables the alarm. 																																								
EH1 1 0000	<p>Event input DI1 allocation</p> <ul style="list-style-type: none"> Selects Event input DI1 from Event Input Allocation Table. (Refer to 'Event Input' on p.51.) Selection item: <p>Event Input Allocation Table</p> <table border="1"> <thead> <tr> <th></th> <th>Event input function</th> <th>Input ON (Closed)</th> <th>Input OFF (Open)</th> <th>Remarks</th> </tr> </thead> <tbody> <tr> <td>0000</td> <td>No event</td> <td></td> <td></td> <td></td> </tr> <tr> <td>0001</td> <td>Set value memory</td> <td></td> <td></td> <td></td> </tr> <tr> <td>0002</td> <td>Control ON/OFF</td> <td>Control OFF</td> <td>Control ON</td> <td>Control output OFF function</td> </tr> <tr> <td>0003</td> <td>Direct/Reverse action</td> <td>Direct action</td> <td>Reverse action</td> <td>Always effective</td> </tr> <tr> <td>0004</td> <td>Preset output 1 ON/OFF</td> <td>Preset output</td> <td>Usual control</td> <td>If sensor is burnt out, the unit maintains control with the preset MV.</td> </tr> <tr> <td>0005</td> <td>Preset output 2 ON/OFF</td> <td>Preset output</td> <td>Usual control</td> <td>The unit maintains control with the preset MV.</td> </tr> <tr> <td>0006</td> <td>Auto/Manual control</td> <td>Manual control</td> <td>Automatic control</td> <td>Effective when Auto/Manual control is selected in [OUT/ OFF key function].</td> </tr> </tbody> </table>		Event input function	Input ON (Closed)	Input OFF (Open)	Remarks	0000	No event				0001	Set value memory				0002	Control ON/OFF	Control OFF	Control ON	Control output OFF function	0003	Direct/Reverse action	Direct action	Reverse action	Always effective	0004	Preset output 1 ON/OFF	Preset output	Usual control	If sensor is burnt out, the unit maintains control with the preset MV.	0005	Preset output 2 ON/OFF	Preset output	Usual control	The unit maintains control with the preset MV.	0006	Auto/Manual control	Manual control	Automatic control	Effective when Auto/Manual control is selected in [OUT/ OFF key function].
	Event input function	Input ON (Closed)	Input OFF (Open)	Remarks																																					
0000	No event																																								
0001	Set value memory																																								
0002	Control ON/OFF	Control OFF	Control ON	Control output OFF function																																					
0003	Direct/Reverse action	Direct action	Reverse action	Always effective																																					
0004	Preset output 1 ON/OFF	Preset output	Usual control	If sensor is burnt out, the unit maintains control with the preset MV.																																					
0005	Preset output 2 ON/OFF	Preset output	Usual control	The unit maintains control with the preset MV.																																					
0006	Auto/Manual control	Manual control	Automatic control	Effective when Auto/Manual control is selected in [OUT/ OFF key function].																																					

(*1) The placement of the decimal point follows the selection.

Characters, Factory Default	Setting Item, Function, Setting Range												
EBI 1 0000		Event input function	Input ON (Closed)	Input OFF (Open)	Remarks								
	007	Remote/Local	Remote	Local	Effective when External setting input (EIT option) is ordered.								
	008	Program control RUN/STOP	RUN	STOP	Level action when power is turned on								
	009	Program control Holding/Not holding	Holding	Not holding	Level action when power is turned on								
	010	Program control Advance function	Advance function	Usual control									
	011	Integral action Holding	Integral action Holding	Usual integral action	Control continues with the integral value being held.								
For BCS2, available only when Event input (EIW, EIT, EI options) is ordered. For BCR2/BCD2, available when Serial communication (C5W option) or Event input (EIW, EIT, EI options) is ordered.													
EBI 2 0000	Event input DI2 allocation <ul style="list-style-type: none"> • Selects Event input DI2 from Event Input Allocation Table. (Refer to 'Event Input' on p.51) • Selection item: Same as those of Event input DI1 allocation For BCS2, available only when Event input (EIW, EI option) is ordered. For BCR2/BCD2, available when Serial communication (C5W option) or Event input (EIW, EIT, EI options) is ordered.												
rFLH 1370	External setting input high limit <ul style="list-style-type: none"> • Sets External setting input high limit value. This value corresponds to 20 mA in direct current input. • Setting range: External setting input low limit to Input range high limit (*1) Available only when External setting input (EIT option) is ordered.												
rFLL -200	External setting input low limit <ul style="list-style-type: none"> • Sets External setting input low limit value. This value corresponds to 4 mA in direct current input. • Setting range: Input range low limit to External setting input high limit (*1) Available only when External setting input (EIT option) is ordered.												
rro4 P600	Transmission output type <ul style="list-style-type: none"> • Selects transmission output type. • When changing transmission output type, refer to Section "8.10 Items to be Initialized by Changing Settings" (p.98). • Selection item: <table border="1" style="width: 100%; border-collapse: collapse;"> <tr> <td style="text-align: center;">P600</td> <td>PV transmission</td> </tr> <tr> <td style="text-align: center;">4600</td> <td>SV transmission</td> </tr> <tr> <td style="text-align: center;">7600</td> <td>MV transmission</td> </tr> <tr> <td style="text-align: center;">d600</td> <td>DV transmission</td> </tr> </table> Available only when Transmission output (EIT option) is ordered.					P600	PV transmission	4600	SV transmission	7600	MV transmission	d600	DV transmission
P600	PV transmission												
4600	SV transmission												
7600	MV transmission												
d600	DV transmission												

(*1) The placement of the decimal point follows the selection.

Characters, Factory Default	Setting Item, Function, Setting Range	
FLH 1370	Transmission output high limit	
	<ul style="list-style-type: none"> Sets the Transmission output high limit value. This value corresponds to 20 mA in direct current output. Setting range: 	
	PV, SV transmission	Transmission output low limit to Input range high limit value DC voltage, current inputs: -2000 to 10000
	MV transmission	Transmission output low limit to 105.0%
	DV transmission	Transmission output low limit to Scaling span (*1)
Available only when Transmission output (EIT option) is ordered.		
FLL -200	Transmission output low limit	
	<ul style="list-style-type: none"> Sets the Transmission output low limit value. This value corresponds to 4 mA in direct current output. Selection item: 	
	PV, SV transmission	Input range low limit to Transmission output high limit value DC voltage, current inputs: -2000 to 10000
	MV transmission	-5.0% to Transmission output high limit value
	DV transmission	-Scaling span to Transmission output high limit value (*1)
Available only when Transmission output (EIT option) is ordered.		
400 000	SV1 <ul style="list-style-type: none"> Sets SV1. Setting range: Scaling low limit to Scaling high limit (*1) Available when Control output OFF function or Auto/Manual control is selected in [OUT/OFF key function].	
420 000	SV2 <ul style="list-style-type: none"> Sets SV2. Setting range: Scaling low limit to Scaling high limit (*1) Available for the following: <ul style="list-style-type: none"> When Control output OFF function or Auto/Manual control is selected in [OUT/OFF key function]. For BCS2, Event input (EIW, EIT, EI options) is ordered. For BCR2/BCD2, Serial communication (C5W option) or Event input (EIW, EIT, EI options) is ordered. When 000 (Set value memory) is selected in [Event input DI1/DI2 allocation]. 	
430 000	SV3 <ul style="list-style-type: none"> Sets SV3. Setting range: Scaling low limit to Scaling high limit (*1) Available for the following: <ul style="list-style-type: none"> When Control output OFF function or Auto/Manual control is selected in [OUT/OFF key function]. For BCS2, Event input (EIW, EI options) is ordered. For BCR2/BCD2, Serial communication (C5W option) or Event input (EIW, EIT, EI options) is ordered. When 000 (Set value memory) is selected in [Event input DI1/DI2 allocation]. 	
440 000	SV4 <ul style="list-style-type: none"> Sets SV4. Setting range: Scaling low limit to Scaling high limit (*1) Available for the following: <ul style="list-style-type: none"> When Control output OFF function or Auto/Manual control is selected in [OUT/OFF key function]. For BCS2, Event input (EIW, EI options) is ordered For BCR2/BCD2, Serial communication (C5W option) or Event input (EIW, EIT, EI options) is ordered. When 000 (Set value memory) is selected in [Event input DI1/DI2 allocation]. 	

(*1) The placement of the decimal point follows the selection.

[EV1/EV2 Energized/De-energized]

When $EV1$ (Energized) is selected, Event output 1 or 2 is conductive (ON) while the EV1/EV2 indicator is lit.

Event output 1 or 2 is not conductive (OFF) while the EV1/EV2 indicator is not lit.

When $EV2$ (De-energized) is selected, Event output 1 or 2 is not conductive (OFF) while the EV1/EV2 indicator is lit.

Event output 1 or 2 is conductive (ON) while the EV1/EV2 indicator is not lit.

High limit alarm (when Energized is set) High limit alarm (when De-energized is set)

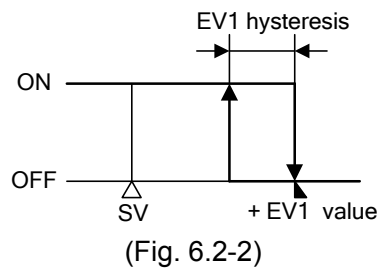
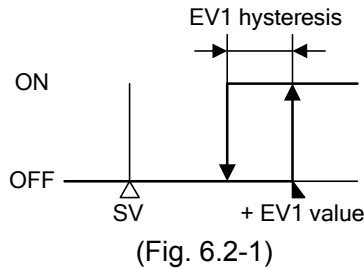

EV1 value and EV1 hysteresis represent EV1 alarm value and EV1 alarm hysteresis respectively. For EV2, read “EV2” for “EV1”.

[Loop Break Alarm]

When the control action is Reverse (Heating) control:

- If the PV does not **reach** the Loop break alarm span setting within the time allotted to assess the Loop break alarm (after the MV has reached 100% or the OUT high limit value), the alarm will be activated.
- Likewise, if the PV does not **drop to** the Loop break alarm span setting within the time allotted to assess the Loop break alarm (after the MV has reached 0% or the OUT low limit value), the alarm will be activated.

When the control action is Direct (Cooling) control:

- If the PV does not **drop to** the Loop break alarm span setting within the time allotted to assess the Loop break alarm (after the MV has reached 100% or the OUT high limit value), the alarm will be activated.
 - Likewise, if the PV does not **reach** the Loop break alarm span setting within the time allotted to assess the Loop break alarm (after the MV has reached 0% or the OUT low limit value), the alarm will be activated.
- If Serial communication (C5W, C5 options) is added, status can be read by reading Status flag 1.

[Event Input]

- If 001 (Set value memory) is selected, the set value memory number will be as follows.

When only Event input DI1 is selected.

Set value memory number	SV1	SV2
DI1	Open	Closed

When only Event input DI2 is selected.

Set value memory number	SV1	SV2
DI2	Open	Closed

When both Event input DI1, DI2 are selected.

Set value memory number	SV1	SV2	SV3	SV4
DI1	Open	Closed	Open	Closed
DI2	Open	Open	Closed	Closed

- Preset value of 004 (Preset output 1 ON/OFF) and 005 (Preset output 2 ON/OFF) can be set in [OUT1/OUT2 MV preset value (p.77)] in Engineering mode 1.

- If 005 (Preset output 2 ON/OFF) is selected in [Event input DI1 allocation], and 006 (Auto/Manual control) is selected in Event input DI2 allocation, and if DI1-COM and DI2-COM terminals are turned ON (Closed) simultaneously, then Preset output 2 will be given priority, and control starts with the MV set in [OUT1/OUT2 MV preset value (p.77)] in Engineering mode 1. In this case, control will be switched to manual control, and MV cannot be changed via keypad.

- Signal edge action from OFF to ON / ON to OFF is engaged.

If 008 (Program control RUN/STOP) is selected in [Event input DI1 allocation], the following action will be performed.

However, only when power is turned ON, Level action is engaged - which follows the input status [ON (Closed) or OFF (Open)] of Event input DI1.

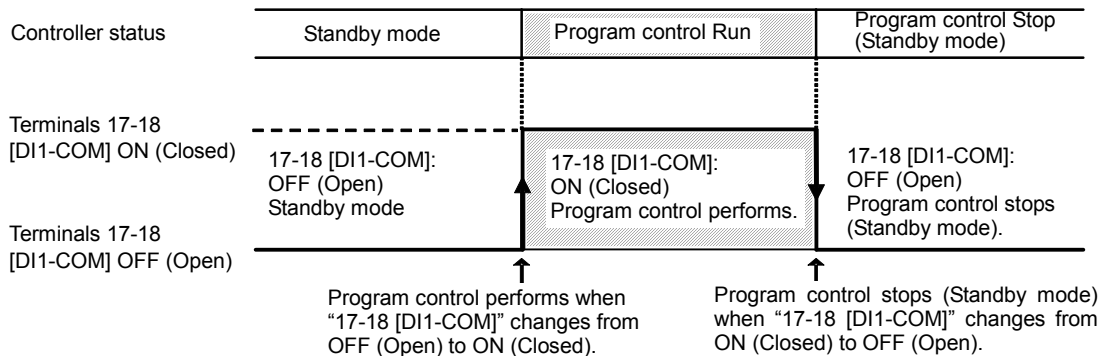

(Fig. 6.2-3)

- OR calculation [if any one is ON (closed), the function activates] begins if the same functions except 001 (Set value memory) have been selected in [Event input DI1/DI2 allocation].

If any terminals DI1-COM or DI2-COM is ON (closed), the function activates.

- If any function except 010 (Program control Advance function) is selected in [Event input DI1/DI2 allocation], Level action is engaged when power is turned ON - which follows the input status [ON (Closed) or OFF (Open)] of Event input DI1/DI2.

[Time Signal Output]

Time signal output activates during Time signal output ON time within each step (number).
 Time signal output ON time follows Time signal output OFF time after the program control starts.

The following program pattern shows that the temperature rises to 200°C for 1 hour, and stays at 200°C for 2 hours after Program control starts.

Step	1	2
Step SV	200°C	200°C
Step time	1:00	2:00

Time signal output (Fig. 6.2-4) is shown when set as follows.

- TS1/TS2 output step number: 2
- TS1/TS2 OFF time: 0:30
- TS1/TS2 ON time: 1:00

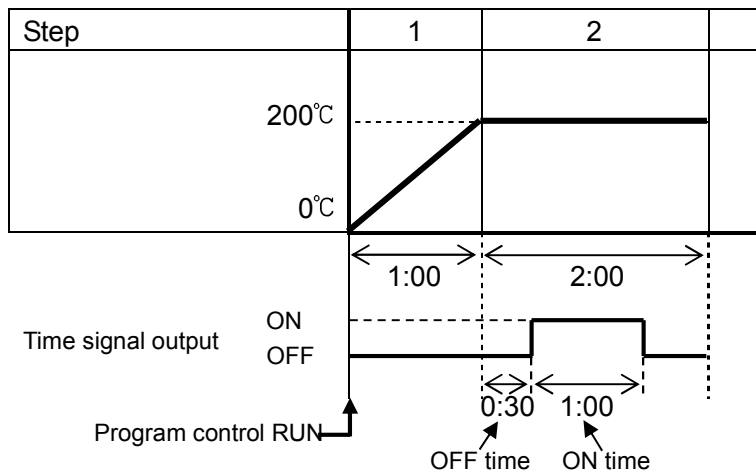

(Fig. 6.2-4)



Time signal output is effective within the step set in [TS1/TS2 output step number].
 For example, if TS1/TS2 ON time is set to “2:00” at the above, Time signal output is turned OFF at the moment when Step 2 is completed.

7. Settings

In this section, Main setting mode, Sub setting mode, Engineering mode 1 and Engineering mode 2 will be explained.

7.1 Main Setting Mode

To enter Main setting mode, press the  key in RUN mode.

Use the  or  key for settings (or selections).

To register the set data, use the  key.

Explanation of setting items:

- Upper left: PV Display: Indicates setting characters.
- Lower left: SV Display: Indicates factory default value.
- Right side: Indicates the setting item, explanation of its function and setting range (or selection item).

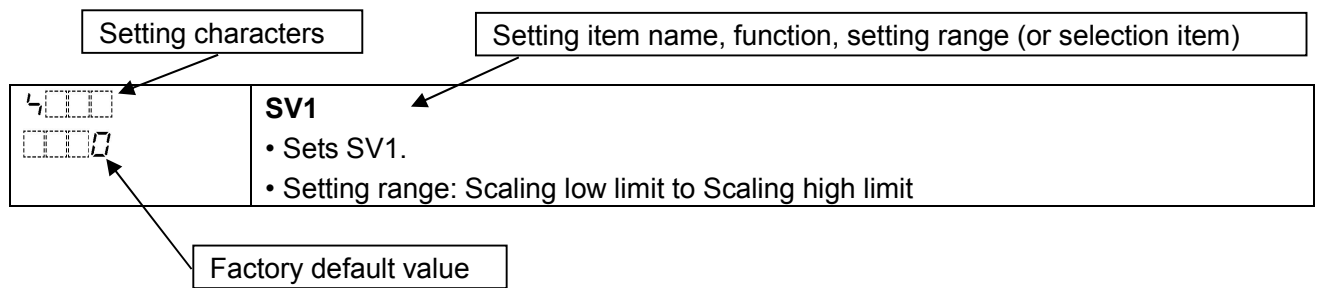

Depending on the selection in [OUT/OFF key function], corresponding item is indicated.

When 'Control output OFF function' or 'Auto/Manual control' is selected in [OUT/OFF key function]:

Characters, Factory Default	Setting Item, Function, Setting Range
4.00 0.00	SV1 • Sets SV1. Corresponds to [SV1] in Initial setting mode. • Setting range: Scaling low limit to Scaling high limit (*1)
4.20 0.00	SV2 (*2) • Sets SV2. Corresponds to [SV2] in Initial setting mode. • Setting range: Scaling low limit to Scaling high limit (*1)
4.30 0.00	SV3 (*2) • Sets SV3. Corresponds to [SV3] in Initial setting mode. • Setting range: Scaling low limit to Scaling high limit (*1)
4.40 0.00	SV4 (*2) • Sets SV4. Corresponds to [SV4] in Initial setting mode. • Setting range: Scaling low limit to Scaling high limit (*1)

(*1) The placement of the decimal point follows the selection.

(*2) When 0001 (Set value memory) is selected in [Event input DI1 allocation] or [Event input DI2 allocation], SV1 and SV2 can be set.
When 0001 (Set value memory) is selected in both [Event input DI1 allocation] and [Event input DI2 allocation], SV1, SV2, SV3 and SV4 can be set.

Available for the following:

- For BCS2, when Event input (EIW, EI option) is ordered
- For BCR2/BCD2, when Serial communication (C5W option) or Event input (EIW, EIT, EI options) is ordered.
- When 0001 (Set value memory) is selected in [Event input DI1/DI2 allocation]

When 'Program control' is selected in [OUT/OFF key function]:

Characters, Factory Default	Setting Item, Function, Setting Range
4.00 0.00	Step 1 SV • Sets Step 1 SV. • Setting range: Scaling low limit to Scaling high limit (*1)
70.1 0000	Step 1 time • Sets Step 1 time. • Setting range: 0:00, or 00:00 to 99:59 If 0:00 is set, Step 1 time will be held, and Fixed value control will be performed using Step 1 SV.
70.1 0.00	Step 1 wait value • Sets Step 1 wait value. • Setting range: 0 to 20% of input span DC voltage, current inputs: 0 to 20% of scaling span (*1) Setting the value to 0 disables this Wait function.

(*1) The placement of the decimal point follows the selection.

Characters, Factory Default	Setting Item, Function, Setting Range
4200 0000	Step 2 SV <ul style="list-style-type: none"> • Sets Step 2 SV. • Setting range: Scaling low limit to Scaling high limit (*1)
r0_2 0000	Step 2 time <ul style="list-style-type: none"> • Sets Step 2 time. • Setting range: 0:00, or 00:00 to 99:59 If 0:00 is set, Step 2 time will be held, and Fixed value control will be performed using Step 2 SV.
w0_2 0000	Step 2 wait value <ul style="list-style-type: none"> • Sets Step 2 wait value. • Setting range: 0 to 20% of input span DC voltage, current inputs: 0 to 20% of scaling span (*1) Setting the value to 0 disables this Wait function.
4300 0000	Step 3 SV <ul style="list-style-type: none"> • Sets Step 3 SV. • Setting range: Scaling low limit to Scaling high limit (*1)
r0_3 0000	Step 3 time <ul style="list-style-type: none"> • Sets Step 3 time. • Setting range: 0:00, or 00:00 to 99:59 If 0:00 is set, Step 3 time will be held, and Fixed value control will be performed using Step 3 SV.
w0_3 0000	Step 3 wait value <ul style="list-style-type: none"> • Sets Step 3 wait value. • Setting range: 0 to 20% of input span DC voltage, current inputs: 0 to 20% of scaling span (*1) Setting the value to 0 disables this Wait function.
4400 0000	Step 4 SV <ul style="list-style-type: none"> • Sets Step 4 SV. • Setting range: Scaling low limit to Scaling high limit (*1)
r0_4 0000	Step 4 time <ul style="list-style-type: none"> • Sets Step 4 time. • Setting range: 0:00, or 00:00 to 99:59 If 0:00 is set, Step 4 time will be held, and Fixed value control will be performed using Step 4 SV.

(*1) The placement of the decimal point follows the selection.

Characters, Factory Default	Setting Item, Function, Setting Range
20.4 000	Step 4 wait value <ul style="list-style-type: none"> • Sets Step 4 wait value. • Setting range: 0 to 20% of input span DC voltage, current inputs: 0 to 20% of scaling span (*1) Setting the value to 0 disables this Wait function.
4500 000	Step 5 SV <ul style="list-style-type: none"> • Sets Step 5 SV. • Setting range: Scaling low limit to Scaling high limit (*1)
70.5 0000	Step 5 time <ul style="list-style-type: none"> • Sets Step 5 time. • Setting range: :--:--:-- or 00:00 to 99:59 If :--:--:-- is set, Step 5 time will be held, and Fixed value control will be performed using Step 5 SV.
20.5 000	Step 5 wait value <ul style="list-style-type: none"> • Sets Step 5 wait value. • Setting range: 0 to 20% of input span DC voltage, current inputs: 0 to 20% of scaling span (*1) Setting the value to 0 disables this Wait function.
4600 000	Step 6 SV <ul style="list-style-type: none"> • Sets Step 6 SV. • Setting range: Scaling low limit to Scaling high limit (*1)
70.6 0000	Step 6 time <ul style="list-style-type: none"> • Sets Step 6 time. • Setting range: :--:--:-- or 00:00 to 99:59 If :--:--:-- is set, Step 6 time will be held, and Fixed value control will be performed using Step 6 SV.
20.6 000	Step 6 wait value <ul style="list-style-type: none"> • Sets Step 6 wait value. • Setting range: 0 to 20% of input span DC voltage, current inputs: 0 to 20% of scaling span (*1) Setting the value to 0 disables this Wait function.
4700 000	Step 7 SV <ul style="list-style-type: none"> • Sets Step 7 SV. • Setting range: Scaling low limit to Scaling high limit (*1)

(*1) The placement of the decimal point follows the selection.

Characters, Factory Default	Setting Item, Function, Setting Range
<pre> r0_7 0000 </pre>	<p>Step 7 time</p> <ul style="list-style-type: none"> • Sets Step 7 time. • Setting range: <pre> []-[]-[]-[] </pre> , or 00:00 to 99:59 If <pre> []-[]-[]-[] </pre> is set, Step 7 time will be held, and Fixed value control will be performed using Step 7 SV.
<pre> w0_7 0000 </pre>	<p>Step 7 wait value</p> <ul style="list-style-type: none"> • Sets Step 7 wait value. • Setting range: 0 to 20% of input span DC voltage, current inputs: 0 to 20% of scaling span (*1) Setting the value to 0 disables this Wait function.
<pre> 4800 0000 </pre>	<p>Step 8 SV</p> <ul style="list-style-type: none"> • Sets Step 8 SV. • Setting range: Scaling low limit to Scaling high limit (*1)
<pre> r0_8 0000 </pre>	<p>Step 8 time</p> <ul style="list-style-type: none"> • Sets Step 8 time. • Setting range: <pre> []-[]-[]-[] </pre> , or 00:00 to 99:59 If <pre> []-[]-[]-[] </pre> is set, Step 8 time will be held, and Fixed value control will be performed using Step 8 SV.
<pre> w0_8 0000 </pre>	<p>Step 8 wait value</p> <ul style="list-style-type: none"> • Sets Step 8 wait value. • Setting range: 0 to 20% of input span DC voltage, current inputs: 0 to 20% of scaling span (*1) Setting the value to 0 disables this Wait function.
<pre> 4900 0000 </pre>	<p>Step 9 SV</p> <ul style="list-style-type: none"> • Sets Step 9 SV. • Setting range: Scaling low limit to Scaling high limit (*1)
<pre> r0_9 0000 </pre>	<p>Step 9 time</p> <ul style="list-style-type: none"> • Sets Step 9 time. • Setting range: <pre> []-[]-[]-[] </pre> , or 00:00 to 99:59 If <pre> []-[]-[]-[] </pre> is set, Step 9 time will be held, and Fixed value control will be performed using Step 9 SV.
<pre> w0_9 0000 </pre>	<p>Step 9 wait value</p> <ul style="list-style-type: none"> • Sets Step 9 wait value. • Setting range: 0 to 20% of input span DC voltage, current inputs: 0 to 20% of scaling span (*1) Setting the value to 0 disables this Wait function.

(*1) The placement of the decimal point follows the selection.

7.2 Sub Setting Mode

To enter Sub setting mode, press the \wedge and \odot keys (in that order) together in RUN mode.

Use the \wedge or \vee key for settings (or selections).

To register the set data, use the \odot key.

Explanation of setting items:

- Upper left: PV Display: Indicates setting characters.
- Lower left: SV Display: Indicates factory default value.
- Right side: Indicates the setting item, explanation of its function and setting range (or selection item).

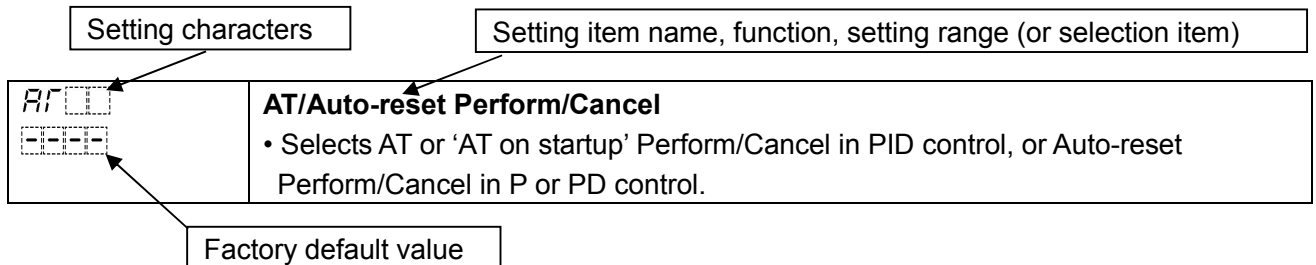

Characters, Factory Default	Setting Item, Function, Setting Range								
AT ---	AT/Auto-reset Perform/Cancel <ul style="list-style-type: none"> • Selects AT or 'AT on startup' Perform/Cancel in PID control action, or Auto-reset Perform/Cancel in P or PD control action. Refer to Sections '8.5 Setting PID Constants (by Performing AT)' (p. 84), and '8.6 Performing Auto-reset' (p. 87). • Selection item: <table border="1"> <tr> <td>---</td> <td>AT/AT on startup/Auto-reset Cancel</td> </tr> <tr> <td>AT</td> <td>AT Perform</td> </tr> <tr> <td>AT_4</td> <td>'AT on startup' Perform</td> </tr> <tr> <td>r4EF</td> <td>Auto-reset Perform</td> </tr> </table> <p>Not available for ON/OFF control or PI control.</p>	---	AT/AT on startup/Auto-reset Cancel	AT	AT Perform	AT_4	'AT on startup' Perform	r4EF	Auto-reset Perform
---	AT/AT on startup/Auto-reset Cancel								
AT	AT Perform								
AT_4	'AT on startup' Perform								
r4EF	Auto-reset Perform								
P 10	OUT1 proportional band <ul style="list-style-type: none"> • Sets OUT1 proportional band. • Setting range: <p>Thermocouple, RTD input without decimal point: 0 to input span$^{\circ}$C ($^{\circ}$F) Thermocouple, RTD input with decimal point: 0.0 to input span$^{\circ}$C ($^{\circ}$F) DC voltage, current inputs: 0.0 to 1000.0% OUT1 becomes ON/OFF control when set to 0 or 0.0.</p>								
I 200	Integral time <ul style="list-style-type: none"> • Sets the integral time. Auto-reset can be performed when PD is control action (I = 0). • Setting range: 0 to 3600 seconds Setting the value to 0 disables integral action. <p>Not available if OUT1 is in ON/OFF control.</p>								
D 50	Derivative time <ul style="list-style-type: none"> • Sets the derivative time. • Setting range: 0 to 1800 seconds Setting the value to 0 disables derivative action. <p>Not available if OUT1 is in ON/OFF control.</p>								

Characters, Factory Default	Setting Item, Function, Setting Range
ARW 50	ARW <ul style="list-style-type: none"> • Sets ARW (anti-reset windup). • Setting range: 0 to 100% Available only when OUT1 is in PID control.
r4Er 100	Manual reset <ul style="list-style-type: none"> • Sets the reset value manually. If auto-reset is executed, the reset value will be automatically set. <ul style="list-style-type: none"> • Setting range: \pmProportional band value If a value larger than 100.0% is set in [OUT1 proportional band], the setting range will be \pm 100.0. Available when OUT1 is in P or PD control.
c 30 Factory default: • Relay contact output: 30 sec. • Non-contact voltage output: 3 sec.	OUT1 proportional cycle <ul style="list-style-type: none"> • Sets proportional cycle for OUT1. For relay contact output, if the proportional cycle time is decreased, the frequency of the relay action increases, and the life of the relay contact is shortened. <ul style="list-style-type: none"> • Setting range: 0.5, or 1 to 120 seconds Not available for direct current output type, or if OUT1 is in ON/OFF control.
HY4 10	OUT1 ON/OFF hysteresis <ul style="list-style-type: none"> • Sets ON/OFF hysteresis for OUT1. • Setting range: 0.1 to 1000.0°C (°F), DC voltage, current inputs: 1 to 10000 (*1) Available only when OUT1 is in ON/OFF control.
oLH 100	OUT1 high limit <ul style="list-style-type: none"> • Sets OUT1 high limit value. • Setting range: OUT1 low limit value to 100% (Direct current output type: OUT1 low limit value to 105%) Not available if OUT1 is relay contact output type or non-contact voltage output type, and if OUT1 is in ON/OFF control.
oLL 000	OUT1 low limit <ul style="list-style-type: none"> • Sets OUT1 low limit value. • Setting range: 0% to OUT1 high limit value (Direct current output type: -5% to OUT1 high limit value) Not available if OUT1 is relay contact output type or non-contact voltage output type, and if OUT1 is in ON/OFF control.
orAR 000	OUT1 rate-of-change <ul style="list-style-type: none"> • Sets changing value of OUT1 MV for 1 second. See 'OUT1 rate-of-change' on p. 63. <ul style="list-style-type: none"> • Setting range: 0 to 100 %/second Setting the value to 0 disables this function. Not available if OUT1 is in ON/OFF control.

(*1) The placement of the decimal point follows the selection.

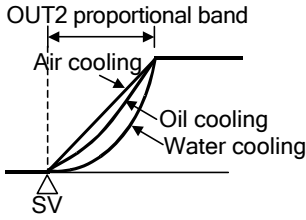
Characters, Factory Default	Setting Item, Function, Setting Range						
cAcF Air□	<p>OUT2 cooling method</p> <ul style="list-style-type: none"> • Selects OUT2 cooling method from air, oil or water cooling.  <p>(Fig. 7.2-1)</p> <ul style="list-style-type: none"> • Selection item: <table border="1" data-bbox="416 577 1481 705"> <tr> <td>Air□</td> <td>Air cooling (linear characteristics)</td> </tr> <tr> <td>oil□</td> <td>Oil cooling (1.5th power of the linear characteristics)</td> </tr> <tr> <td>Water□</td> <td>Water cooling (2nd power of the linear characteristics)</td> </tr> </table> <p>Available when Heating/Cooling control [DS, DA, EV2(*1), EV2+D□ options] is ordered. Not available if OUT1 is in ON/OFF control or if OUT2 is in ON/OFF control.</p>	Air□	Air cooling (linear characteristics)	oil□	Oil cooling (1.5th power of the linear characteristics)	Water□	Water cooling (2nd power of the linear characteristics)
Air□	Air cooling (linear characteristics)						
oil□	Oil cooling (1.5th power of the linear characteristics)						
Water□	Water cooling (2nd power of the linear characteristics)						
P_b□ □□ 10	<p>OUT2 proportional band</p> <ul style="list-style-type: none"> • Sets the proportional band for OUT2. • Setting range: Thermocouple, RTD input without decimal point: 0 to Input span °C (°F) Thermocouple, RTD input with decimal point: 0.0 to Input span °C (°F) DC voltage, current inputs: 0.0 to 1000.0% <p>When set to 0 or 0.0, OUT2 becomes ON/OFF control, and the item selected in [OUT2 cooling method] will be disabled.</p> <p>Available when Heating/Cooling control [DS, DA, EV2(*1), EV2+D□ options] is ordered. Not available if OUT1 is in ON/OFF control.</p>						
c_b□ □□ 30 Factory default: EV2(*2), EV2+DR: 30 sec. DS: 3 sec.	<p>OUT2 proportional cycle</p> <ul style="list-style-type: none"> • Sets proportional cycle for OUT2. <p>For relay contact output, if the proportional cycle time is decreased, the frequency of the relay action increases, and the life of the relay contact is shortened.</p> <ul style="list-style-type: none"> • Setting range: 0.5, or 1 to 120 seconds <p>Available when Heating/Cooling control [DS, DA, EV2(*1), EV2+D□ options] is ordered. Not available if OUT1 is in ON/OFF control, OUT2 is in ON/OFF control or OUT2 is direct current output type.</p>						
Hh4b □□ 10	<p>OUT2 ON/OFF hysteresis</p> <ul style="list-style-type: none"> • Sets ON/OFF hysteresis for OUT2. • Setting range: 0.1 to 1000.0°C (°F), DC voltage, current inputs: 1 to 10000 (*2) <p>Available when Heating/Cooling control [DS, DA, EV2(*1), EV2+D□ options] is ordered. Available when OUT2 is in ON/OFF control.</p>						
oLHb □□ 100	<p>OUT2 high limit</p> <ul style="list-style-type: none"> • Sets OUT2 high limit value. • Setting range: OUT2 low limit value to 100% (Direct current output type: OUT2 low limit value to 105%) <p>Available when Heating/Cooling control [DS, DA, EV2(*1), EV2+D□ options] is ordered. Not available if OUT2 is relay contact output type or non-contact voltage output type and OUT1 is in ON/OFF control. Not available if OUT2 is relay contact output type or non-contact voltage output type and OUT2 is in ON/OFF control.</p>						

(*1) When □□ 19 (Heating/Cooling control relay contact output) is selected in [Event output EV2 allocation].

(*2) The placement of the decimal point follows the selection.

Characters, Factory Default	Setting Item, Function, Setting Range																									
oLLb 000	OUT2 low limit <ul style="list-style-type: none"> Sets OUT2 low limit value. Setting range: 0% to OUT2 high limit value (Direct current output type: -5% to OUT2 high limit value) Available when Heating/Cooling control [DS, DA, EV2(*1), EV2+D□ options] is ordered. Not available if OUT2 is relay contact output type or non-contact voltage output type and OUT1 is in ON/OFF control. Not available if OUT2 is relay contact output type or non-contact voltage output type and OUT2 is in ON/OFF control.																									
db□□ 000	Overlap/Dead band <ul style="list-style-type: none"> Sets the overlap band or dead band for OUT1 and OUT2. <ul style="list-style-type: none"> + Set value: Dead band – Set value: Overlap band Setting range: -200.0 to 200.0°C (°F), DC voltage, current inputs: -2000 to 2000 (*2) Available when Heating/Cooling control [DS, DA, EV2(*1), EV2+D□ options] is ordered.																									
conf HEAT	Direct/Reverse action <ul style="list-style-type: none"> Selects either Reverse (Heating) or Direct (Cooling) control action. <table border="1" style="width: 100%; border-collapse: collapse;"> <tr> <td style="width: 30%; text-align: center;">HEAT</td> <td style="text-align: center;">Reverse (Heating) action</td> </tr> <tr> <td style="text-align: center;">COOL</td> <td style="text-align: center;">Direct (Cooling) action</td> </tr> </table>		HEAT	Reverse (Heating) action	COOL	Direct (Cooling) action																				
HEAT	Reverse (Heating) action																									
COOL	Direct (Cooling) action																									
A□□ 000	EV1 alarm value <ul style="list-style-type: none"> Sets EV1 alarm value. Corresponds to [EV1 alarm value] in Initial setting mode. EV1 alarm value matches EV1 low limit alarm value in the following cases: □□□4 (Alarm output, High/Low limits independent alarm), □□□5 (Alarm output, High/Low limit range independent alarm), or □□12 (Alarm output, High/Low limits with standby independent alarm) is selected in [Event output EV1 allocation]. Setting range: <table border="1" style="width: 100%; border-collapse: collapse;"> <tr> <td style="width: 50%;">High limit alarm</td> <td>-(Input span) to Input span °C (°F) (*2) (*3)</td> </tr> <tr> <td>Low limit alarm</td> <td>-(Input span) to Input span °C (°F) (*2) (*3)</td> </tr> <tr> <td>High/Low limits alarm</td> <td>0 to Input span °C (°F) (*2) (*3)</td> </tr> <tr> <td>High/Low limits independent alarm</td> <td>0 to Input span °C (°F) (*2) (*3)</td> </tr> <tr> <td>High/Low limit range alarm</td> <td>0 to Input span °C (°F) (*2) (*3)</td> </tr> <tr> <td>High/Low limit range independent alarm</td> <td>0 to Input span °C (°F) (*2) (*3)</td> </tr> <tr> <td>Process high alarm</td> <td>Input range low limit to Input range high limit (*2) (*4)</td> </tr> <tr> <td>Process low alarm</td> <td>Input range low limit to Input range high limit (*2) (*4)</td> </tr> <tr> <td>High limit with standby alarm</td> <td>-(Input span) to Input span °C (°F) (*2) (*3)</td> </tr> <tr> <td>Low limit with standby alarm</td> <td>-(Input span) to Input span °C (°F) (*2) (*3)</td> </tr> <tr> <td>High/Low limits with standby alarm</td> <td>0 to Input span °C (°F) (*2) (*3)</td> </tr> <tr> <td>High/Low limits with standby independent alarm</td> <td>0 to Input span °C (°F) (*2) (*3)</td> </tr> </table> Available when any alarm from □□□1 (Alarm output, High limit alarm) to □□12 (Alarm output, High/Low limits with standby independent alarm) is selected in [Event output EV1 allocation].		High limit alarm	-(Input span) to Input span °C (°F) (*2) (*3)	Low limit alarm	-(Input span) to Input span °C (°F) (*2) (*3)	High/Low limits alarm	0 to Input span °C (°F) (*2) (*3)	High/Low limits independent alarm	0 to Input span °C (°F) (*2) (*3)	High/Low limit range alarm	0 to Input span °C (°F) (*2) (*3)	High/Low limit range independent alarm	0 to Input span °C (°F) (*2) (*3)	Process high alarm	Input range low limit to Input range high limit (*2) (*4)	Process low alarm	Input range low limit to Input range high limit (*2) (*4)	High limit with standby alarm	-(Input span) to Input span °C (°F) (*2) (*3)	Low limit with standby alarm	-(Input span) to Input span °C (°F) (*2) (*3)	High/Low limits with standby alarm	0 to Input span °C (°F) (*2) (*3)	High/Low limits with standby independent alarm	0 to Input span °C (°F) (*2) (*3)
High limit alarm	-(Input span) to Input span °C (°F) (*2) (*3)																									
Low limit alarm	-(Input span) to Input span °C (°F) (*2) (*3)																									
High/Low limits alarm	0 to Input span °C (°F) (*2) (*3)																									
High/Low limits independent alarm	0 to Input span °C (°F) (*2) (*3)																									
High/Low limit range alarm	0 to Input span °C (°F) (*2) (*3)																									
High/Low limit range independent alarm	0 to Input span °C (°F) (*2) (*3)																									
Process high alarm	Input range low limit to Input range high limit (*2) (*4)																									
Process low alarm	Input range low limit to Input range high limit (*2) (*4)																									
High limit with standby alarm	-(Input span) to Input span °C (°F) (*2) (*3)																									
Low limit with standby alarm	-(Input span) to Input span °C (°F) (*2) (*3)																									
High/Low limits with standby alarm	0 to Input span °C (°F) (*2) (*3)																									
High/Low limits with standby independent alarm	0 to Input span °C (°F) (*2) (*3)																									

(*1) When □□19 (Heating/Cooling control relay contact output) is selected in [Event output EV2 allocation]

(*2) The placement of the decimal point follows the selection.

(*3) For DC voltage, current inputs, the input span is the same as the scaling span.

(*4) For DC voltage, current inputs, input range low (or high) limit value is the same as scaling low (or high) limit value.

Characters, Factory Default	Setting Item, Function, Setting Range
A 1H 000	<p>EV1 high limit alarm value</p> <ul style="list-style-type: none"> Sets EV1 high limit alarm value. <p>This value is available only for the following: <input type="checkbox"/>004 (Alarm output, High/Low limits independent alarm), <input type="checkbox"/>005 (Alarm output, High/Low limit range independent alarm), or <input type="checkbox"/>012 (Alarm output, High/Low limits with standby independent alarm) is selected in [Event output EV1 allocation].</p> <p>Corresponds to [EV1 high limit alarm value] in Initial setting mode.</p> <ul style="list-style-type: none"> Setting range: Same as those of EV1 alarm value
A20 000	<p>EV2 alarm value</p> <ul style="list-style-type: none"> Sets EV2 alarm value. <p>Corresponds to [EV2 alarm value] in Initial setting mode.</p> <p>EV2 alarm value matches EV2 low limit alarm value in the following cases: <input type="checkbox"/>004 (Alarm output, High/Low limits independent alarm), <input type="checkbox"/>005 (Alarm output, High/Low limit range independent alarm), or <input type="checkbox"/>012 (Alarm output, High/Low limits with standby independent alarm) is selected in [Event output EV2 allocation].</p> <ul style="list-style-type: none"> Setting range: Same as those of EV1 alarm value <p>Available when Event output EV2 (EV2, EV2+D<input type="checkbox"/> options) is ordered.</p> <p>Available only when <input type="checkbox"/>001 (Alarm output, High limit alarm) to <input type="checkbox"/>012 (Alarm output, High/Low limits with standby independent alarm) is selected in [Event output EV2 allocation].</p>
A2H 000	<p>EV2 high limit alarm value</p> <ul style="list-style-type: none"> Sets EV2 high limit alarm value. <p>This value is available only for the following: <input type="checkbox"/>004 (Alarm output, High/Low limits independent alarm), <input type="checkbox"/>005 (Alarm output, High/Low limit range independent alarm), or <input type="checkbox"/>012 (Alarm output, High/Low limits with standby independent alarm) is selected in [Event output EV2 allocation].</p> <p>Corresponds to [EV2 high limit alarm value] in Initial setting mode.</p> <ul style="list-style-type: none"> Setting range: Same as those of EV1 alarm value <p>Available when Event output EV2 (EV2, EV2+D<input type="checkbox"/> options) is ordered.</p>
H 1 000 H 1 and CT1 current value are alternately indicated on the PV Display.	<p>Heater burnout alarm 1 value</p> <ul style="list-style-type: none"> Sets the heater current value for Heater burnout alarm 1. <p>Corresponds to [Heater burnout alarm 1 value] in Initial setting mode.</p> <p>Characters <i>H 1</i> and CT1 current value are indicated alternately on the PV Display. When OUT1 is ON, the CT1 current value is updated. When OUT1 is OFF, the unit memorizes the previous value when OUT1 was ON. Upon returning to set limits, the alarm will stop.</p> <ul style="list-style-type: none"> Setting range: 20 A: 0.0 to 20.0 A 100 A: 0.0 to 100.0 A Setting to 0.0 disables the alarm. <p>Not available for direct current output type.</p> <p>Available only when Heater burnout alarm (C5W, EIW, W options) is ordered.</p>

Characters, Factory Default	Setting Item, Function, Setting Range
<p><i>H2</i> </p> <p><i>CT2</i> and <i>CT2</i> current value are alternately indicated on the PV Display.</p>	<p>Heater burnout alarm 2 value</p> <ul style="list-style-type: none"> • Sets the heater current value for Heater burnout alarm 2. Available only when using 3-phase. Corresponds to [Heater burnout alarm 2 value] in Initial setting mode. Characters <i>H2</i> and <i>CT2</i> current value are indicated alternately on the PV Display. When OUT1 is ON, the CT2 current value is updated. When OUT1 is OFF, the unit memorizes the previous value when OUT1 was ON. Upon returning to set limits, the alarm will stop. • Setting range: 20 A: 0.0 to 20.0 A 100 A: 0.0 to 100.0 A Setting to 0.0 disables the alarm. Not available for direct current output type. Available only when Heater burnout alarm (C5W, EIW, W options) is ordered.
<p><i>LP_F</i> </p>	<p>Loop break alarm time</p> <ul style="list-style-type: none"> • Sets the time to assess the Loop break alarm. Corresponds to [Loop break alarm time] in Initial setting mode. Refer to 'Loop Break Alarm' on p.50. • Setting range: 0 to 200 minutes Setting to 0 (zero) disables the alarm.
<p><i>LP_H</i> </p>	<p>Loop break alarm span</p> <ul style="list-style-type: none"> • Sets the action span to assess the Loop break alarm. Corresponds to [Loop Break alarm span] in Initial setting mode. Refer to 'Loop Break Alarm' on p.50. • Setting range: Thermocouple, RTD input without decimal point: 0 to 150°C (°F) Thermocouple, RTD input with decimal point: 0.0 to 150.0°C (°F) DC voltage, current inputs: 0 to 1500 (*1) Setting to 0 (zero) disables the alarm.

(*1) The placement of the decimal point follows the selection.

[OUT1 rate-of-change]

For Heating control, if PV is lower than SV, the output is generally turned from OFF to ON as shown in (Fig. 7.2-2).

If OUT1 rate-of-change is set, the output can be changed by the rate-of-change (Fig. 7.2-3).

This control is suitable for high temperature heaters (which are made from molybdenum, tungsten or platinum, etc., and used at approx. 1500 to 1800°C) which are easily burnt out from turning on electricity rapidly.

● Usual output

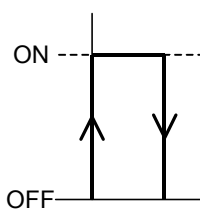

(Fig. 7.2-2)

● Output when Output rate-of-change is set

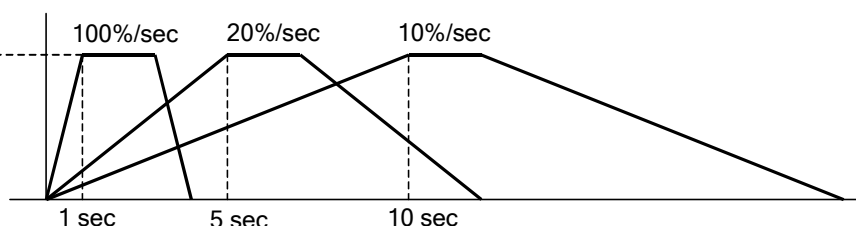

(Fig. 7.2-3)

7.3 Engineering Mode 1

To enter Engineering mode 1, press and hold the \wedge and \vee keys (in that order) together for 3 seconds in RUN mode.

Use the \wedge or \vee key for settings (or selections).

To register the set data, use the \odot key.

Explanation of setting items:

- Upper left: PV Display: Indicates setting characters.
- Lower left: SV Display: Indicates factory default value.
- Right side: Indicates the setting item, explanation of its function and setting range (or selection item).

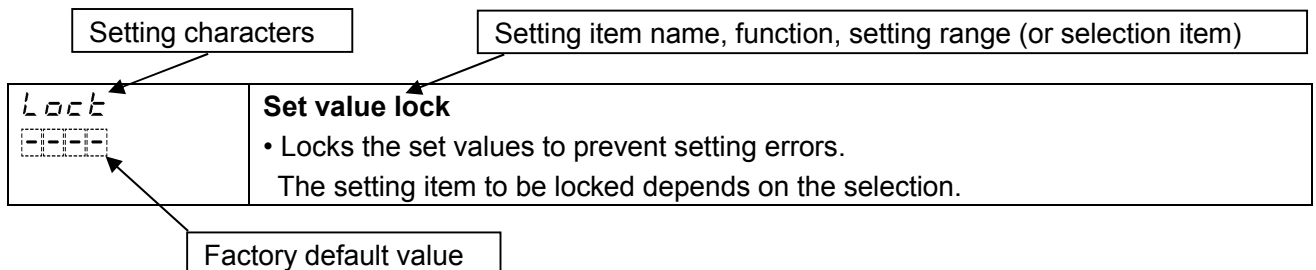

Characters, Factory Default	Setting Item, Function, Setting Range			
<i>Lock</i> ---	Set value lock • Locks the set values to prevent setting errors. The setting item to be locked depends on the selection. • Selection item:			
		Change via Keypad	Change via Software Communication	
	<i>---</i>	Unlock	All set values can be changed.	All set values can be changed.
	<i>Loc 1</i>	Lock 1	None of the set values can be changed.	
	<i>Loc 2</i>	Lock 2	In Fixed value control, only SV and Alarm value can be changed. In Program control, Step SV, Step time and Alarm value can be changed.	
	<i>Loc 3</i>	Lock 3	All set values can be changed.	Setting items – except Input type, Controller/Converter – can be changed temporarily via software communication. However, if power is turned ON again, the setting values revert to the values before Lock 3, 4 or 5 was selected.
	<i>Loc 4</i>	Lock 4	None of the set values can be changed.	
	<i>Loc 5</i>	Lock 5	In Fixed value control, only SV and Alarm value can be changed. In Program control, Step SV, Step time and Alarm value can be changed.	

Characters, Factory Default	Setting Item, Function, Setting Range																																																																				
EBI 1 □000	Event input DI1 allocation <ul style="list-style-type: none"> • Selects Event input DI1 from the Event Input Allocation Table. Corresponds to [Event input DI1 allocation] in Initial setting mode. • Selection item: Event Input Allocation Table <table border="1" style="width: 100%; border-collapse: collapse;"> <thead> <tr> <th style="width: 10%;"></th> <th style="width: 30%;">Event input function</th> <th style="width: 15%;">Input ON (Closed)</th> <th style="width: 15%;">Input OFF (Open)</th> <th style="width: 30%;">Remarks</th> </tr> </thead> <tbody> <tr> <td>□000</td> <td>No event</td> <td></td> <td></td> <td></td> </tr> <tr> <td>□001</td> <td>Set value memory</td> <td></td> <td></td> <td></td> </tr> <tr> <td>□002</td> <td>Control ON/OFF</td> <td>Control OFF</td> <td>Control ON</td> <td>Control output OFF function</td> </tr> <tr> <td>□003</td> <td>Direct/Reverse action</td> <td>Direct action</td> <td>Reverse action</td> <td>Always effective</td> </tr> <tr> <td>□004</td> <td>Preset output 1 ON/OFF</td> <td>Preset output</td> <td>Usual control</td> <td>If sensor is burnt out, the unit maintains control with the preset MV.</td> </tr> <tr> <td>□005</td> <td>Preset output 2 ON/OFF</td> <td>Preset output</td> <td>Usual control</td> <td>The unit maintains control with the preset MV.</td> </tr> <tr> <td>□006</td> <td>Auto/Manual control</td> <td>Manual control</td> <td>Automatic control</td> <td>Effective when Auto/Manual control is selected in [OUT/OFF key function].</td> </tr> <tr> <td>□007</td> <td>Remote/Local</td> <td>Remote</td> <td>Local</td> <td>Effective when External setting input (EIT option) is ordered.</td> </tr> <tr> <td>□008</td> <td>Program control RUN/STOP</td> <td>RUN</td> <td>STOP</td> <td>Level action when power is turned on</td> </tr> <tr> <td>□009</td> <td>Program control Holding/Not holding</td> <td>Holding</td> <td>Not holding</td> <td>Level action when power is turned on</td> </tr> <tr> <td>□010</td> <td>Program control Advance function</td> <td>Advance function</td> <td>Usual control</td> <td></td> </tr> <tr> <td>□011</td> <td>Integral action holding</td> <td>Integral action holding</td> <td>Usual integral action</td> <td>Control continues with the integral value being held.</td> </tr> </tbody> </table> <p>For BCS2, available only when Event input (EIW, EIT, EI options) is ordered. For BCR2/BCD2, available when Serial communication (C5W option) or Event input (EIW, EIT, EI options) is ordered.</p>					Event input function	Input ON (Closed)	Input OFF (Open)	Remarks	□000	No event				□001	Set value memory				□002	Control ON/OFF	Control OFF	Control ON	Control output OFF function	□003	Direct/Reverse action	Direct action	Reverse action	Always effective	□004	Preset output 1 ON/OFF	Preset output	Usual control	If sensor is burnt out, the unit maintains control with the preset MV.	□005	Preset output 2 ON/OFF	Preset output	Usual control	The unit maintains control with the preset MV.	□006	Auto/Manual control	Manual control	Automatic control	Effective when Auto/Manual control is selected in [OUT/OFF key function].	□007	Remote/Local	Remote	Local	Effective when External setting input (EIT option) is ordered.	□008	Program control RUN/STOP	RUN	STOP	Level action when power is turned on	□009	Program control Holding/Not holding	Holding	Not holding	Level action when power is turned on	□010	Program control Advance function	Advance function	Usual control		□011	Integral action holding	Integral action holding	Usual integral action	Control continues with the integral value being held.
	Event input function	Input ON (Closed)	Input OFF (Open)	Remarks																																																																	
□000	No event																																																																				
□001	Set value memory																																																																				
□002	Control ON/OFF	Control OFF	Control ON	Control output OFF function																																																																	
□003	Direct/Reverse action	Direct action	Reverse action	Always effective																																																																	
□004	Preset output 1 ON/OFF	Preset output	Usual control	If sensor is burnt out, the unit maintains control with the preset MV.																																																																	
□005	Preset output 2 ON/OFF	Preset output	Usual control	The unit maintains control with the preset MV.																																																																	
□006	Auto/Manual control	Manual control	Automatic control	Effective when Auto/Manual control is selected in [OUT/OFF key function].																																																																	
□007	Remote/Local	Remote	Local	Effective when External setting input (EIT option) is ordered.																																																																	
□008	Program control RUN/STOP	RUN	STOP	Level action when power is turned on																																																																	
□009	Program control Holding/Not holding	Holding	Not holding	Level action when power is turned on																																																																	
□010	Program control Advance function	Advance function	Usual control																																																																		
□011	Integral action holding	Integral action holding	Usual integral action	Control continues with the integral value being held.																																																																	
EBI 2 □000	Event input DI2 allocation <ul style="list-style-type: none"> • Selects Event input DI2 from the Event Input Allocation Table. Corresponds to [Event input DI2 allocation] in Initial setting mode. • Selection item: Same as Event input DI1 allocation <p>For BCS2, available only when Event input (EIW, EI options) is ordered. For BCR2/BCD2, available when Serial communication (C5W option) or Event input (EIW, EIT, EI options) is ordered.</p>																																																																				

Characters, Factory Default	Setting Item, Function, Setting Range																																																										
E601 000	<p>Event output EV1 allocation</p> <ul style="list-style-type: none"> • Selects Event output EV1 from the Event Output Allocation Table below. Corresponds to [Event output EV1 allocation] in Initial setting mode. • When changing Event output EV1 allocation, refer to Section “8.10 Items to be Initialized by Changing Settings” (p.98). • Selection item: <p>Event Output Allocation Table</p> <table border="1" data-bbox="419 436 1479 1787"> <tr> <td>000</td> <td>No event</td> <td></td> </tr> <tr> <td>001</td> <td>Alarm output, High limit alarm</td> <td></td> </tr> <tr> <td>002</td> <td>Alarm output, Low limit alarm</td> <td></td> </tr> <tr> <td>003</td> <td>Alarm output, High/Low limits alarm</td> <td></td> </tr> <tr> <td>004</td> <td>Alarm output, High/Low limits independent alarm</td> <td></td> </tr> <tr> <td>005</td> <td>Alarm output, High/Low limit range alarm</td> <td></td> </tr> <tr> <td>006</td> <td>Alarm output, High/Low limit range independent alarm</td> <td></td> </tr> <tr> <td>007</td> <td>Alarm output, Process high alarm</td> <td></td> </tr> <tr> <td>008</td> <td>Alarm output, Process low alarm</td> <td></td> </tr> <tr> <td>009</td> <td>Alarm output, High limit with standby</td> <td></td> </tr> <tr> <td>010</td> <td>Alarm output, Low limit with standby</td> <td></td> </tr> <tr> <td>011</td> <td>Alarm output, High/Low limits with standby alarm</td> <td></td> </tr> <tr> <td>012</td> <td>Alarm output, High/Low limits with standby independent alarm</td> <td></td> </tr> <tr> <td>013</td> <td>Heater burnout alarm output</td> <td></td> </tr> <tr> <td>014</td> <td>Loop break alarm output</td> <td></td> </tr> <tr> <td>015</td> <td>Time signal output</td> <td>Turns OFF or ON during Program control, by setting OFF time and ON time within the step set in [Step number].</td> </tr> <tr> <td>016</td> <td>Output during AT</td> <td>Turns ON during AT.</td> </tr> <tr> <td>017</td> <td>Pattern end output</td> <td>Turns ON when Program control ends, and remains ON until turned OFF by pressing the © key.</td> </tr> <tr> <td>018</td> <td>Output by communication command</td> <td>Turns OFF or ON by communication command 00E4H during Serial communication. B0 EV1 output 0: OFF 1: ON B1 EV2 output 0: OFF 1: ON</td> </tr> </table>		000	No event		001	Alarm output, High limit alarm		002	Alarm output, Low limit alarm		003	Alarm output, High/Low limits alarm		004	Alarm output, High/Low limits independent alarm		005	Alarm output, High/Low limit range alarm		006	Alarm output, High/Low limit range independent alarm		007	Alarm output, Process high alarm		008	Alarm output, Process low alarm		009	Alarm output, High limit with standby		010	Alarm output, Low limit with standby		011	Alarm output, High/Low limits with standby alarm		012	Alarm output, High/Low limits with standby independent alarm		013	Heater burnout alarm output		014	Loop break alarm output		015	Time signal output	Turns OFF or ON during Program control, by setting OFF time and ON time within the step set in [Step number].	016	Output during AT	Turns ON during AT.	017	Pattern end output	Turns ON when Program control ends, and remains ON until turned OFF by pressing the © key.	018	Output by communication command	Turns OFF or ON by communication command 00E4H during Serial communication. B0 EV1 output 0: OFF 1: ON B1 EV2 output 0: OFF 1: ON
000	No event																																																										
001	Alarm output, High limit alarm																																																										
002	Alarm output, Low limit alarm																																																										
003	Alarm output, High/Low limits alarm																																																										
004	Alarm output, High/Low limits independent alarm																																																										
005	Alarm output, High/Low limit range alarm																																																										
006	Alarm output, High/Low limit range independent alarm																																																										
007	Alarm output, Process high alarm																																																										
008	Alarm output, Process low alarm																																																										
009	Alarm output, High limit with standby																																																										
010	Alarm output, Low limit with standby																																																										
011	Alarm output, High/Low limits with standby alarm																																																										
012	Alarm output, High/Low limits with standby independent alarm																																																										
013	Heater burnout alarm output																																																										
014	Loop break alarm output																																																										
015	Time signal output	Turns OFF or ON during Program control, by setting OFF time and ON time within the step set in [Step number].																																																									
016	Output during AT	Turns ON during AT.																																																									
017	Pattern end output	Turns ON when Program control ends, and remains ON until turned OFF by pressing the © key.																																																									
018	Output by communication command	Turns OFF or ON by communication command 00E4H during Serial communication. B0 EV1 output 0: OFF 1: ON B1 EV2 output 0: OFF 1: ON																																																									
A12A no00	<p>EV1 alarm value 0 Enabled/Disabled</p> <ul style="list-style-type: none"> • When EV1 alarm value is 0 (zero), alarm action can be Enabled or Disabled. Corresponds to [EV1 alarm value 0 Enabled/Disabled] in Initial setting mode. • Selection item: <table border="1" data-bbox="419 1948 1479 2027"> <tr> <td>no00</td> <td>Disabled</td> </tr> <tr> <td>4E40</td> <td>Enabled</td> </tr> </table> <p>Available when 001 (Alarm output, High limit alarm) to 005 (Alarm output, High/Low limit range independent alarm), 009 (Alarm output, High limit with standby alarm) to 012 (Alarm output, High/Low limits with standby independent alarm) are selected in [Event output EV1 allocation].</p>		no00	Disabled	4E40	Enabled																																																					
no00	Disabled																																																										
4E40	Enabled																																																										

Characters, Factory Default	Setting Item, Function, Setting Range																								
R 100 000	<p>EV1 alarm value</p> <ul style="list-style-type: none"> • Sets EV1 alarm value. Corresponds to [EV1 alarm value] in Initial setting mode. EV1 alarm value matches EV1 low limit alarm value in the following cases: <input type="checkbox"/>004 (Alarm output, High/Low limits independent alarm), <input type="checkbox"/>005 (Alarm output, High/Low limit range independent alarm), or <input type="checkbox"/>012 (Alarm output, High/Low limits with standby independent alarm) is selected in [Event output EV1 allocation]. • Setting range: <table border="1" data-bbox="419 539 1471 1193"> <tr> <td>High limit alarm</td> <td>-(Input span) to Input span °C (°F) (*1) (*2)</td> </tr> <tr> <td>Low limit alarm</td> <td>-(Input span) to Input span °C (°F) (*1) (*2)</td> </tr> <tr> <td>High/Low limits alarm</td> <td>0 to Input span °C (°F) (*1) (*2)</td> </tr> <tr> <td>High/Low limits independent alarm</td> <td>0 to Input span °C (°F) (*1) (*2)</td> </tr> <tr> <td>High/Low limit range alarm</td> <td>0 to Input span °C (°F) (*1) (*2)</td> </tr> <tr> <td>High/Low limit range independent alarm</td> <td>0 to Input span °C (°F) (*1) (*2)</td> </tr> <tr> <td>Process high alarm</td> <td>Input range low limit to Input range high limit (*1) (*3)</td> </tr> <tr> <td>Process low alarm</td> <td>Input range low limit to Input range high limit (*1) (*3)</td> </tr> <tr> <td>High limit with standby alarm</td> <td>-(Input span) to Input span °C (°F) (*1) (*2)</td> </tr> <tr> <td>Low limit with standby alarm</td> <td>-(Input span) to Input span °C (°F) (*1) (*2)</td> </tr> <tr> <td>High/Low limits with standby alarm</td> <td>0 to Input span °C (°F) (*1) (*2)</td> </tr> <tr> <td>High/Low limits with standby independent alarm</td> <td>0 to Input span °C (°F) (*1) (*2)</td> </tr> </table> <p>Available when any alarm from <input type="checkbox"/>001 (Alarm output, High limit alarm) to <input type="checkbox"/>012 (Alarm output, High/Low limits with standby independent alarm) is selected in [Event output EV1 allocation].</p>	High limit alarm	-(Input span) to Input span °C (°F) (*1) (*2)	Low limit alarm	-(Input span) to Input span °C (°F) (*1) (*2)	High/Low limits alarm	0 to Input span °C (°F) (*1) (*2)	High/Low limits independent alarm	0 to Input span °C (°F) (*1) (*2)	High/Low limit range alarm	0 to Input span °C (°F) (*1) (*2)	High/Low limit range independent alarm	0 to Input span °C (°F) (*1) (*2)	Process high alarm	Input range low limit to Input range high limit (*1) (*3)	Process low alarm	Input range low limit to Input range high limit (*1) (*3)	High limit with standby alarm	-(Input span) to Input span °C (°F) (*1) (*2)	Low limit with standby alarm	-(Input span) to Input span °C (°F) (*1) (*2)	High/Low limits with standby alarm	0 to Input span °C (°F) (*1) (*2)	High/Low limits with standby independent alarm	0 to Input span °C (°F) (*1) (*2)
High limit alarm	-(Input span) to Input span °C (°F) (*1) (*2)																								
Low limit alarm	-(Input span) to Input span °C (°F) (*1) (*2)																								
High/Low limits alarm	0 to Input span °C (°F) (*1) (*2)																								
High/Low limits independent alarm	0 to Input span °C (°F) (*1) (*2)																								
High/Low limit range alarm	0 to Input span °C (°F) (*1) (*2)																								
High/Low limit range independent alarm	0 to Input span °C (°F) (*1) (*2)																								
Process high alarm	Input range low limit to Input range high limit (*1) (*3)																								
Process low alarm	Input range low limit to Input range high limit (*1) (*3)																								
High limit with standby alarm	-(Input span) to Input span °C (°F) (*1) (*2)																								
Low limit with standby alarm	-(Input span) to Input span °C (°F) (*1) (*2)																								
High/Low limits with standby alarm	0 to Input span °C (°F) (*1) (*2)																								
High/Low limits with standby independent alarm	0 to Input span °C (°F) (*1) (*2)																								
R 1H0 000	<p>EV1 high limit alarm value</p> <ul style="list-style-type: none"> • Sets EV1 high limit alarm value. This value is available only for the following: <input type="checkbox"/>004 (Alarm output, High/Low limits independent alarm), <input type="checkbox"/>005 (Alarm output, High/Low limit range independent alarm), <input type="checkbox"/>012 (Alarm output, High/Low limits with standby independent alarm) is selected in [Event output EV1 allocation]. Corresponds to [EV1 high limit alarm value] in Initial setting mode. • Setting range: Same as those of EV1 alarm value 																								
R 1H4 00 10	<p>EV1 alarm hysteresis</p> <ul style="list-style-type: none"> • Sets EV1 alarm hysteresis. Corresponds to [EV1 alarm hysteresis] in Initial setting mode. • Setting range: 0.1 to 1000.0°C (°F), DC voltage, current inputs: 1 to 10000 (*1) <p>Available when any alarm from <input type="checkbox"/>001 (Alarm output, High limit alarm) to <input type="checkbox"/>012 (Alarm output, High/Low limits with standby independent alarm) is selected in [Event output EV1 allocation].</p>																								

(*1) The placement of the decimal point follows the selection.

(*2) For DC voltage, current inputs, the input span is the same as the scaling span.

(*3) For DC voltage, current inputs, input range low (or high) limit value is the same as scaling low (or high) limit value.

Characters, Factory Default	Setting Item, Function, Setting Range				
R 124 0000	<p>EV1 alarm delay time</p> <ul style="list-style-type: none"> Sets EV1 alarm action delay time. Corresponds to [EV1 alarm delay time] in Initial setting mode. When setting time has elapsed after the input enters the alarm output range, the alarm is activated. Setting range: 0 to 10000 seconds <p>Available when any alarm from 0001 (Alarm output, High limit alarm) to 0012 (Alarm output, High/Low limits with standby independent alarm) is selected in [Event output EV1 allocation].</p>				
R 125 noL	<p>EV1 alarm Energized/De-energized</p> <ul style="list-style-type: none"> Selects Energized/De-energized status for EV1 alarm. Corresponds to [EV1 alarm Energized/De-energized] in Initial setting mode. (Refer to 'EV1/EV2 Energized/De-energized' on p.50.) Selection item: <table border="1" data-bbox="427 689 1465 775"> <tr> <td data-bbox="427 689 587 730">noL</td> <td data-bbox="587 689 1465 730">Energized</td> </tr> <tr> <td data-bbox="427 730 587 775">rEB4</td> <td data-bbox="587 730 1465 775">De-energized</td> </tr> </table> <p>Available when any alarm from 0001 (Alarm output, High limit alarm) to 0012 (Alarm output, High/Low limits with standby independent alarm) is selected in [Event output EV1 allocation].</p>	noL	Energized	rEB4	De-energized
noL	Energized				
rEB4	De-energized				
F4 14 001	<p>TS1 output step number</p> <ul style="list-style-type: none"> Sets the step number for which Time signal output TS1 is turned OFF or ON during Program control. Corresponds to [TS1 output step number] in Initial setting mode. Setting range: 1 to 9 <p>Available only when 0015 (Time signal output) is selected in [Event output EV1 allocation].</p>				
F4 1F 0000	<p>TS1 OFF time</p> <ul style="list-style-type: none"> Sets Time signal output TS1 OFF time. Corresponds to [TS1 OFF time] in Initial setting mode. Setting range: 00:00 to 99:59 (*1) <p>Available only when 0015 (Time signal output) is selected in [Event output EV1 allocation].</p>				
F4 1a 0000	<p>TS1 ON time</p> <ul style="list-style-type: none"> Sets Time signal output TS1 ON time. Corresponds to [TS1 ON time] in Initial setting mode. Setting range: 00:00 to 99:59 (*1) <p>Available only when 0015 (Time signal output) is selected in [Event output EV1 allocation].</p>				

(*1) Time unit follows the selection in [Step time unit].

Characters, Factory Default	Setting Item, Function, Setting Range	
EV02 000	Event output EV2 allocation <ul style="list-style-type: none"> • Selects Event output EV2 from the Event Output Allocation Table below. Corresponds to [Event output EV2 allocation] in Initial setting mode. • When changing Event output EV2, refer to Section “8.10 Items to be Initialized by Changing Settings” (p.98). • Selection item: Event Output Allocation Table	
000	No event	
001	Alarm output, High limit alarm	
002	Alarm output, Low limit alarm	
003	Alarm output, High/Low limits alarm	
004	Alarm output, High/Low limits independent alarm	
005	Alarm output, High/Low limit range alarm	
006	Alarm output, High/Low limit range independent alarm	
007	Alarm output, Process high alarm	
008	Alarm output, Process low alarm	
009	Alarm output, High limit with standby alarm	
010	Alarm output, Low limit with standby alarm	
011	Alarm output, High/Low limits with standby alarm	
012	Alarm output, High/Low limits with standby independent alarm	
013	Heater burnout alarm output	
014	Loop break alarm output	
015	Time signal output	Turns OFF or ON during Program control, by setting OFF time and ON time within the step set in [Step number].
016	Output during AT	Turns ON during AT.
017	Pattern end output	Turns ON when Program control ends, and remains ON until turned OFF by pressing the © key.
018	Output by communication command	Turns OFF or ON by communication command 00E4H during Serial communication. B0 EV1 output 0: OFF 1: ON B1 EV2 output 0: OFF 1: ON
019	Heating/Cooling control relay contact output (*1)	Works as Control output OUT2 (Heating/Cooling control).
Available only when Event output EV2 (EV2, EV2+D□ options) is ordered.		

(*1) Not available if Heating/Cooling control (EV2+D□ option) is ordered.

Characters, Factory Default	Setting Item, Function, Setting Range																								
R23A no□□	<p>EV2 alarm value 0 Enabled/Disabled</p> <ul style="list-style-type: none"> When EV2 alarm value is 0 (zero), alarm action can be Enabled or Disabled. Corresponds to [EV2 alarm value 0 Enabled/Disabled] in Initial setting mode. Selection item: <table border="1" style="width: 100%; border-collapse: collapse;"> <tr> <td style="width: 30%; text-align: center;">no□□</td> <td style="text-align: center;">Disabled</td> </tr> <tr> <td style="text-align: center;">yE4□</td> <td style="text-align: center;">Enabled</td> </tr> </table> <p>Available only when Event output EV2 (EV2, EV2+D□ options) is ordered. Available when any alarm from □□□1 (Alarm output, High limit alarm) to □□□5 (Alarm output, High/Low limit range independent alarm), and from □□□9 (Alarm output, High limit with standby alarm) to □□12 (Alarm output, High/Low limits with standby independent alarm) is selected in [Event output EV2 allocation].</p>	no□□	Disabled	yE4□	Enabled																				
no□□	Disabled																								
yE4□	Enabled																								
R2□□ □□□□	<p>EV2 alarm value</p> <ul style="list-style-type: none"> Sets EV2 alarm value. Corresponds to [EV2 alarm value] in Initial setting mode. EV2 alarm value matches EV2 low limit alarm value in the following cases: □□□4 (Alarm output, High/Low limits independent alarm), □□□5 (Alarm output, High/Low limit range independent alarm), or □□12 (Alarm output, High/Low limits with standby independent alarm) is selected in [Event output EV2 allocation]. Setting range: <table border="1" style="width: 100%; border-collapse: collapse;"> <tr> <td style="width: 50%;">High limit alarm</td> <td>-(Input span) to Input span °C (°F) (*1) (*2)</td> </tr> <tr> <td>Low limit alarm</td> <td>-(Input span) to Input span °C (°F) (*1) (*2)</td> </tr> <tr> <td>High/Low limits alarm</td> <td>0 to Input span °C (°F) (*1) (*2)</td> </tr> <tr> <td>High/Low limits independent alarm</td> <td>0 to Input span °C (°F) (*1) (*2)</td> </tr> <tr> <td>High/Low limit range alarm</td> <td>0 to Input span °C (°F) (*1) (*2)</td> </tr> <tr> <td>High/Low limit range independent alarm</td> <td>0 to Input span °C (°F) (*1) (*2)</td> </tr> <tr> <td>Process high alarm</td> <td>Input range low limit to Input range high limit (*1) (*3)</td> </tr> <tr> <td>Process low alarm</td> <td>Input range low limit to Input range high limit (*1) (*3)</td> </tr> <tr> <td>High limit with standby alarm</td> <td>-(Input span) to Input span °C (°F) (*1) (*2)</td> </tr> <tr> <td>Low limit with standby alarm</td> <td>-(Input span) to Input span °C (°F) (*1) (*2)</td> </tr> <tr> <td>High/Low limits with standby alarm</td> <td>0 to Input span °C (°F) (*1) (*2)</td> </tr> <tr> <td>High/Low limits with standby independent alarm</td> <td>0 to Input span °C (°F) (*1) (*2)</td> </tr> </table> <p>Available only when Event output EV2 (EV2, EV2+D□ options) is ordered. Available when any alarm from □□□1 (Alarm output, High limit alarm) to □□12 (Alarm output, High/Low limits with standby independent alarm) is selected in [Event output EV2 allocation].</p>	High limit alarm	-(Input span) to Input span °C (°F) (*1) (*2)	Low limit alarm	-(Input span) to Input span °C (°F) (*1) (*2)	High/Low limits alarm	0 to Input span °C (°F) (*1) (*2)	High/Low limits independent alarm	0 to Input span °C (°F) (*1) (*2)	High/Low limit range alarm	0 to Input span °C (°F) (*1) (*2)	High/Low limit range independent alarm	0 to Input span °C (°F) (*1) (*2)	Process high alarm	Input range low limit to Input range high limit (*1) (*3)	Process low alarm	Input range low limit to Input range high limit (*1) (*3)	High limit with standby alarm	-(Input span) to Input span °C (°F) (*1) (*2)	Low limit with standby alarm	-(Input span) to Input span °C (°F) (*1) (*2)	High/Low limits with standby alarm	0 to Input span °C (°F) (*1) (*2)	High/Low limits with standby independent alarm	0 to Input span °C (°F) (*1) (*2)
High limit alarm	-(Input span) to Input span °C (°F) (*1) (*2)																								
Low limit alarm	-(Input span) to Input span °C (°F) (*1) (*2)																								
High/Low limits alarm	0 to Input span °C (°F) (*1) (*2)																								
High/Low limits independent alarm	0 to Input span °C (°F) (*1) (*2)																								
High/Low limit range alarm	0 to Input span °C (°F) (*1) (*2)																								
High/Low limit range independent alarm	0 to Input span °C (°F) (*1) (*2)																								
Process high alarm	Input range low limit to Input range high limit (*1) (*3)																								
Process low alarm	Input range low limit to Input range high limit (*1) (*3)																								
High limit with standby alarm	-(Input span) to Input span °C (°F) (*1) (*2)																								
Low limit with standby alarm	-(Input span) to Input span °C (°F) (*1) (*2)																								
High/Low limits with standby alarm	0 to Input span °C (°F) (*1) (*2)																								
High/Low limits with standby independent alarm	0 to Input span °C (°F) (*1) (*2)																								
R24□ □□□□	<p>EV2 high limit alarm value</p> <ul style="list-style-type: none"> Sets EV2 high limit alarm value. This value is available only for the following: □□□4 (Alarm output, High/Low limits independent alarm), □□□5 (Alarm output, High/Low limit range independent alarm), or □□12 (Alarm output, High/Low limits with standby independent alarm) is selected in [Event output EV2 allocation]. Corresponds to [EV2 high limit alarm value] in Initial setting mode. Setting range: Same as those of EV2 alarm value <p>Available only when Event output EV2 (EV2, EV2+D□ options) is ordered.</p>																								

(*1) The placement of the decimal point follows the selection.

(*2) For DC voltage, current inputs, the input span is the same as the scaling span.

(*3) For DC voltage, current inputs, input range low (or high) limit value is the same as scaling low (or high) limit value.

Characters, Factory Default	Setting Item, Function, Setting Range				
R2H4 □□ 10	<p>EV2 alarm hysteresis</p> <ul style="list-style-type: none"> Sets EV2 alarm hysteresis. Corresponds to [EV2 alarm hysteresis] in Initial setting mode. Setting range: 0.1 to 1000.0°C (°F), DC voltage, current inputs: 1 to 10000 (*1) <p>Available only when Event output EV2 (EV2, EV2+D□ options) is ordered. Available when any alarm from □□□ 1 (Alarm output, High limit alarm) to □□ 12 (Alarm output, High/Low limits with standby independent alarm) is selected in [Event output EV2 allocation].</p>				
R2D4 □□□□	<p>EV2 alarm delay time</p> <ul style="list-style-type: none"> Sets EV2 alarm action delay time. Corresponds to [EV2 alarm delay time] in Initial setting mode. When setting time has elapsed after the input enters the alarm output range, the alarm is activated. Setting range: 0 to 10000 seconds <p>Available only when Event output EV2 (EV2, EV2+D□ options) is ordered. Available when any alarm from □□□ 1 (Alarm output, High limit alarm) to □□ 12 (Alarm output, High/Low limits with standby independent alarm) is selected in [Event output EV2 allocation].</p>				
R2Lñ □□□□	<p>EV2 alarm Energized/De-energized</p> <ul style="list-style-type: none"> Selects Energized/De-energized status for EV2 alarm. Corresponds to [EV2 alarm Energized/De-energized] in Initial setting mode. Refer to 'EV1/EV2 Energized/De-energized' (p.50). Selection item: <table border="1" style="width: 100%; border-collapse: collapse;"> <tr> <td style="text-align: center;">□□□□</td> <td style="text-align: center;">Energized</td> </tr> <tr> <td style="text-align: center;">rE44</td> <td style="text-align: center;">De-energized</td> </tr> </table> <p>Available only when Event output EV2 (EV2, EV2+D□ options) is ordered. Available when any alarm from □□□ 1 (Alarm output, High limit alarm) to □□ 12 (Alarm output, High/Low limits with standby independent alarm) is selected in [Event output EV2 allocation].</p>	□□□□	Energized	rE44	De-energized
□□□□	Energized				
rE44	De-energized				
F424 □□□ 1	<p>TS2 output step number</p> <ul style="list-style-type: none"> Sets the step number for which Time signal output TS2 is turned OFF or ON during Program control. Corresponds to [TS2 output step number] in Initial setting mode. Setting range: 1 to 9 <p>Available only when □□ 15 (Time signal output) is selected in [Event output EV2 allocation].</p>				
F42F 0000	<p>TS2 OFF time</p> <ul style="list-style-type: none"> Sets Time signal output TS2 OFF time. Corresponds to [TS2 OFF time] in Initial setting mode. Setting range: 00:00 to 99:59 (*2) <p>Available only when □□ 15 (Time signal output) is selected in [Event output EV2 allocation].</p>				
F42o 0000	<p>TS2 ON time</p> <ul style="list-style-type: none"> Sets Time signal output TS2 ON time. Corresponds to [TS2 ON time] in Initial setting mode. Setting range: 00:00 to 99:59 (*2) <p>Available only when □□ 15 (Time signal output) is selected in [Event output EV2 allocation].</p>				

(*1) The placement of the decimal point follows the selection.

(*2) Time unit follows the selection in [Step time unit].

Characters, Factory Default	Setting Item, Function, Setting Range			
406□ 1000	<p>Sensor correction coefficient</p> <ul style="list-style-type: none"> Sets sensor correction coefficient. <p>Sets slope of input value from a sensor.</p> $\text{PV after sensor correction} = \text{Current PV} \times (\text{Sensor correction coefficient}) + (\text{Sensor correction value})$ <p>Refer to Section '9.1 Input Value Correction' (p. 99).</p> <ul style="list-style-type: none"> Setting range: -10.000 to 10.000 			
40□□ □□□□	<p>Sensor correction</p> <ul style="list-style-type: none"> This corrects the input value from the sensor. <p>When a sensor cannot be set at the exact location where control is desired, the sensor-measured temperature may deviate from the temperature in the controlled location. When using multiple controllers, sometimes the measured temperatures do not concur due to differences in sensor accuracy or dispersion of load capacities. In such a case, the control can be set at the desired temperature by adjusting the input value of sensors.</p> $\text{PV after sensor correction} = \text{Current PV} \times (\text{Sensor correction coefficient}) + (\text{Sensor correction value})$ <p>Refer to Section '9.1 Input Value Correction' (p.99).</p> <ul style="list-style-type: none"> Setting range: -1000.0 to 1000.0°C (°F) DC voltage, current inputs: -10000 to 10000 (*1) 			
F1L□ □□□□	<p>PV filter time constant</p> <ul style="list-style-type: none"> Sets PV filter time constant. <p>If the value is set too high, it affects control results due to the delay of response.</p> <ul style="list-style-type: none"> Setting range: 0.0 to 10.0 seconds 			
cñ4L noñL	<p>Communication protocol</p> <ul style="list-style-type: none"> Selects communication protocol. Selection item: 			
	<table border="1"> <tr> <td data-bbox="419 1245 571 1288">noñL</td> <td data-bbox="571 1245 1479 1288">Shinko protocol</td> </tr> </table>	noñL	Shinko protocol	
	noñL	Shinko protocol		
	<table border="1"> <tr> <td data-bbox="419 1288 571 1330">ñodR</td> <td data-bbox="571 1288 1479 1330">Modbus ASCII</td> </tr> </table>	ñodR	Modbus ASCII	
	ñodR	Modbus ASCII		
	<table border="1"> <tr> <td data-bbox="419 1330 571 1373">ñodr</td> <td data-bbox="571 1330 1479 1373">Modbus RTU</td> </tr> </table>	ñodr	Modbus RTU	
ñodr	Modbus RTU			
<table border="1"> <tr> <td data-bbox="419 1373 571 1415">ññ4L</td> <td data-bbox="571 1373 1479 1415">Shinko protocol (JC command allocated)</td> </tr> </table>	ññ4L	Shinko protocol (JC command allocated)		
ññ4L	Shinko protocol (JC command allocated)			
<table border="1"> <tr> <td data-bbox="419 1415 571 1458">ññdR</td> <td data-bbox="571 1415 1479 1458">Modbus ASCII (JC command allocated)</td> </tr> <tr> <td data-bbox="419 1458 571 1491">ññdr</td> <td data-bbox="571 1458 1479 1491">Modbus RTU (JC command allocated)</td> </tr> </table>	ññdR	Modbus ASCII (JC command allocated)	ññdr	Modbus RTU (JC command allocated)
ññdR	Modbus ASCII (JC command allocated)			
ññdr	Modbus RTU (JC command allocated)			
<p>Available only when Serial communication (C5W, C5 options) is ordered.</p>				
cñno □□□□	<p>Instrument number</p> <ul style="list-style-type: none"> Sets the instrument number. <p>The instrument numbers should be set one by one when multiple instruments are connected in Serial communication, otherwise communication is impossible.</p> <ul style="list-style-type: none"> Setting range: 0 to 95 <p>Available only when Serial communication (C5W, C5 options) is ordered.</p>			

(*1) The placement of the decimal point follows the selection.

Characters, Factory Default	Setting Item, Function, Setting Range												
cñ4P □□96	Communication speed <ul style="list-style-type: none"> • Selects a communication speed equal to that of the host computer. • Selection item: <table border="1" data-bbox="435 300 718 427"> <tr> <td>□□96</td> <td>9600 bps</td> </tr> <tr> <td>□□192</td> <td>19200 bps</td> </tr> <tr> <td>□□384</td> <td>38400 bps</td> </tr> </table> <p>Available only when Serial communication (C5W, C5 options) is ordered.</p>	□□96	9600 bps	□□192	19200 bps	□□384	38400 bps						
□□96	9600 bps												
□□192	19200 bps												
□□384	38400 bps												
cñFF 7EBn	Data bit/Parity <ul style="list-style-type: none"> • Selects data bit and parity. • Selection item: <table border="1" data-bbox="435 589 774 831"> <tr> <td>8non</td> <td>8 bits/No parity</td> </tr> <tr> <td>7non</td> <td>7 bits/No parity</td> </tr> <tr> <td>8EEn</td> <td>8 bits/Even</td> </tr> <tr> <td>7EEn</td> <td>7 bits/Even</td> </tr> <tr> <td>8odd</td> <td>8 bits/Odd</td> </tr> <tr> <td>7odd</td> <td>7 bits/Odd</td> </tr> </table> <p>Available only when Serial communication (C5W, C5 options) is ordered.</p>	8non	8 bits/No parity	7non	7 bits/No parity	8EEn	8 bits/Even	7EEn	7 bits/Even	8odd	8 bits/Odd	7odd	7 bits/Odd
8non	8 bits/No parity												
7non	7 bits/No parity												
8EEn	8 bits/Even												
7EEn	7 bits/Even												
8odd	8 bits/Odd												
7odd	7 bits/Odd												
cñ4I □□□1	Stop bit <ul style="list-style-type: none"> • Selects the stop bit. • Selection item: <table border="1" data-bbox="435 999 651 1077"> <tr> <td>□□□1</td> <td>1 bit</td> </tr> <tr> <td>□□□2</td> <td>2 bits</td> </tr> </table> <p>Available only when Serial communication (C5W, C5 options) is ordered.</p>	□□□1	1 bit	□□□2	2 bits								
□□□1	1 bit												
□□□2	2 bits												
cñd4 □□10	Response delay time <ul style="list-style-type: none"> • Response from the controller can be delayed after receiving command from the host computer. If Response delay time is changed via software communication, the changed delay time will be reflected from that response data. • Setting range: 0 to 1000 ms <p>Available only when Serial communication (C5W, C5 options) is ordered.</p>												
4d_b □□□0	SVTC bias <ul style="list-style-type: none"> • Control desired value (SV) adds SVTC bias value to the value received by the SVTC command. • Setting range: ±20% of input span DC voltage, current inputs: ±20% of scaling span (*1) <p>Available when Shinko protocol is selected in [Communication protocol].</p> <p>Available when Serial communication (C5W, C5 options) is ordered.</p>												
rEñI LocL	Remote/Local <ul style="list-style-type: none"> • Selects Remote (Remote operation) or Local (keypad operation) setting of the SV. • Selection item: <table border="1" data-bbox="435 1805 686 1883"> <tr> <td>LocL</td> <td>Local</td> </tr> <tr> <td>rEñI</td> <td>Remote</td> </tr> </table> <p>Available only when External setting input (EIT option) is ordered.</p>	LocL	Local	rEñI	Remote								
LocL	Local												
rEñI	Remote												

(*1) The placement of the decimal point follows the selection.

Characters, Factory Default	Setting Item, Function, Setting Range								
rFLH 1370	External setting input high limit <ul style="list-style-type: none"> Sets External setting input high limit value. (This value corresponds to 20 mA in direct current input.) Setting range: External setting input low limit to Input range high limit Available only when External setting input (EIT option) is ordered. 								
rFLl -200	External setting input low limit <ul style="list-style-type: none"> Sets External setting input low limit value. (This value corresponds to 4 mA in direct current input.) Setting range: Input range low limit to External setting input high limit Available only when External setting input (EIT option) is ordered. 								
rF_b 000	Remote bias <ul style="list-style-type: none"> During remote action, SV includes the remote bias value. Setting range: $\pm 20\%$ of input span DC voltage, current inputs: $\pm 20\%$ of scaling span (*1) Available only when External setting input (EIT option) is ordered. 								
Trout Pb00	Transmission output type <ul style="list-style-type: none"> Selects the transmission output type. When changing transmission output type, refer to Section “8.10 Items to be Initialized by Changing Settings” (p.98). Selection item: <table border="1"> <tr> <td>Pb00</td> <td>PV transmission</td> </tr> <tr> <td>4b00</td> <td>SV transmission</td> </tr> <tr> <td>n̄b00</td> <td>MV transmission</td> </tr> <tr> <td>db00</td> <td>DV transmission</td> </tr> </table> <p>Available only when Transmission output (EIT option) is ordered.</p>	Pb00	PV transmission	4b00	SV transmission	n̄b00	MV transmission	db00	DV transmission
Pb00	PV transmission								
4b00	SV transmission								
n̄b00	MV transmission								
db00	DV transmission								
TrLH 1370	Transmission output high limit <ul style="list-style-type: none"> Sets the Transmission output high limit value. (This value corresponds to 20 mA in direct current output.) Setting range: <table border="1"> <tr> <td>PV, SV transmission</td> <td>Transmission output low limit to Input range high limit value</td> </tr> <tr> <td>MV transmission</td> <td>Transmission output low limit to 105.0%</td> </tr> <tr> <td>DV transmission</td> <td>Transmission output low limit to Scaling span (*1)</td> </tr> </table> <p>Available only when Transmission output (EIT option) is ordered.</p>	PV, SV transmission	Transmission output low limit to Input range high limit value	MV transmission	Transmission output low limit to 105.0%	DV transmission	Transmission output low limit to Scaling span (*1)		
PV, SV transmission	Transmission output low limit to Input range high limit value								
MV transmission	Transmission output low limit to 105.0%								
DV transmission	Transmission output low limit to Scaling span (*1)								
TrLl -200	Transmission output low limit <ul style="list-style-type: none"> Sets the Transmission output low limit value. (This value corresponds to 4 mA in direct current output.) Setting range: <table border="1"> <tr> <td>PV, SV transmission</td> <td>Input range low limit to Transmission output high limit value</td> </tr> <tr> <td>MV transmission</td> <td>-5.0% to Transmission output high limit value</td> </tr> <tr> <td>DV transmission</td> <td>-Scaling span to Transmission output high limit value (*1)</td> </tr> </table> <p>Available only when Transmission output (EIT option) is ordered.</p>	PV, SV transmission	Input range low limit to Transmission output high limit value	MV transmission	-5.0% to Transmission output high limit value	DV transmission	-Scaling span to Transmission output high limit value (*1)		
PV, SV transmission	Input range low limit to Transmission output high limit value								
MV transmission	-5.0% to Transmission output high limit value								
DV transmission	-Scaling span to Transmission output high limit value (*1)								
n̄_40 n̄l n̄0	Step time unit <ul style="list-style-type: none"> Selects the Step time unit for the Program control. Selection item: <table border="1"> <tr> <td>n̄l n̄0</td> <td>Hours:Minutes</td> </tr> <tr> <td>4E00</td> <td>Minutes:Seconds</td> </tr> </table> <p>Available only when Program control is selected in [OUT/OFF key function].</p>	n̄l n̄0	Hours:Minutes	4E00	Minutes:Seconds				
n̄l n̄0	Hours:Minutes								
4E00	Minutes:Seconds								

(*1) The placement of the decimal point follows the selection.

Characters, Factory Default	Setting Item, Function, Setting Range
PrEF 4rOP	Power restore action <ul style="list-style-type: none"> • Selects the program status if a power failure occurs mid-program and it is restored. • Selection item:
	4rOP Stops after power is restored.
	conF Continues (resumes) after power is restored.
	HoLd Suspends (on hold) after power is restored.
	Available only when Program control is selected in [OUT/OFF key function].
4.4B □□□	Program start temperature <ul style="list-style-type: none"> • Sets the step temperature when Program control starts. • Setting range: Scaling low limit value to Scaling high limit value (*1) Available only when Program control is selected in [OUT/OFF key function].
4.4L Pb□□	Program control start type <ul style="list-style-type: none"> • Selects the Program control start type. • Selection item:
	Pb□□ PV start
	Pbr□ PVR start
	4b□□ SV start
	Available only when Program control is selected in [OUT/OFF key function].
rEPF □□□	Number of repetitions <ul style="list-style-type: none"> • Sets the number of repetitions for Program control. • Setting range: 0 to 10000 times Available only when Program control is selected in [OUT/OFF key function].
rR44 4B4F	SV Rise/Fall rate start type <ul style="list-style-type: none"> • When control output is turned from OFF to ON, or switched from Manual to Automatic control, SV start or PV start can be selected for SV rise rate or SV fall rate action. • When power is turned ON, PV start is adopted for SV Rise/Fall rate action, regardless of the selected type. • Selection item:
	4B4F SV start
	PB4F PV start
rRFU □□□	SV rise rate <ul style="list-style-type: none"> • Sets SV rise rate (rising value for 1 minute). When the SV is adjusted, it approaches the new SV by the preset rate-of-change (°C/min, °F/min). When the power is turned on, the control starts from the PV, and approaches the SV by the rate-of-change (°C/min, °F/min). <ul style="list-style-type: none"> • Setting range: 0 to 10000°C/min (°F/min) Thermocouple, RTD inputs with a decimal point: 0.0 to 1000.0°C/min (°F/min) DC voltage, current inputs: 0 to 10000/min Setting to 0 or 0.0 disables this function.

(*1) The placement of the decimal point follows the selection.

Characters, Factory Default	Setting Item, Function, Setting Range								
rAFd 000	SV fall rate <ul style="list-style-type: none"> Sets SV fall rate (falling value for 1 minute). When the SV is adjusted, it approaches the new SV by the preset rate-of-change (°C/min, °F/min). When the power is turned on, the control starts from the PV and approaches the SV by the rate-of-change (°C/min, °F/min). Setting range: 0 to 10000°C/min (°F/min) Thermocouple, RTD inputs with a decimal point: 0.0 to 1000.0°C/min (°F/min) DC voltage, current inputs: 0 to 10000/min Setting to 0 or 0.0 disables this function. 								
P4B oFF	Indication when control output OFF <ul style="list-style-type: none"> Selects the indication when control output is OFF. Selection item: <table border="1" data-bbox="421 663 1481 826"> <tr> <td data-bbox="421 663 588 703">oFF</td> <td data-bbox="588 663 1481 703">OFF indication</td> </tr> <tr> <td data-bbox="421 703 588 743">R oFF</td> <td data-bbox="588 703 1481 743">No indication</td> </tr> <tr> <td data-bbox="421 743 588 784">P4B</td> <td data-bbox="588 743 1481 784">PV indication</td> </tr> <tr> <td data-bbox="421 784 588 826">P4BL</td> <td data-bbox="588 784 1481 826">PV indication + Any Alarm active</td> </tr> </table>	oFF	OFF indication	R oFF	No indication	P4B	PV indication	P4BL	PV indication + Any Alarm active
oFF	OFF indication								
R oFF	No indication								
P4B	PV indication								
P4BL	PV indication + Any Alarm active								
AF_b 020	AT bias <ul style="list-style-type: none"> Sets bias value for the AT. AT point is automatically determined by the deviation between PV and SV. Refer to Section '8.5 Setting PID Constants (by performing AT)' (p.84). Setting range: 0 to 50°C (0 to 100°F) or 0.0 to 50.0°C (0.0 to 100.0°F) <p>Available only for PID control. Not available for DC voltage, current inputs</p>								
AF_t 010	AT gain <ul style="list-style-type: none"> Sets proportional band ratio calculated by performing AT or 'AT on startup'. Setting range: 0.1 to 10.0 								
EoUF oFF	Output status when input errors occur <ul style="list-style-type: none"> Selects the output status when input errors occur. Selection item: <table border="1" data-bbox="421 1373 1481 1453"> <tr> <td data-bbox="421 1373 588 1413">oFF</td> <td data-bbox="588 1373 1481 1413">Output OFF</td> </tr> <tr> <td data-bbox="421 1413 588 1453">oN</td> <td data-bbox="588 1413 1481 1453">Output ON</td> </tr> </table> <p>Available for direct current and voltage inputs, and direct current output type.</p>	oFF	Output OFF	oN	Output ON				
oFF	Output OFF								
oN	Output ON								
nAnU oFF	OUT/OFF key function <ul style="list-style-type: none"> Selects OUT/OFF key function. Selection item: <table border="1" data-bbox="421 1615 1481 1738"> <tr> <td data-bbox="421 1615 588 1655">oFF</td> <td data-bbox="588 1615 1481 1655">Control output OFF function</td> </tr> <tr> <td data-bbox="421 1655 588 1695">nAnU</td> <td data-bbox="588 1655 1481 1695">Auto/Manual control</td> </tr> <tr> <td data-bbox="421 1695 588 1738">Pr oG</td> <td data-bbox="588 1695 1481 1738">Program control</td> </tr> </table>	oFF	Control output OFF function	nAnU	Auto/Manual control	Pr oG	Program control		
oFF	Control output OFF function								
nAnU	Auto/Manual control								
Pr oG	Program control								
nAr4 AU o	Auto/Manual control after power ON <ul style="list-style-type: none"> When the power to the controller is turned ON, selects whether the unit starts using Automatic control or Manual control. Selection item: <table border="1" data-bbox="421 1899 1481 1980"> <tr> <td data-bbox="421 1899 588 1939">AU o</td> <td data-bbox="588 1899 1481 1939">Automatic control</td> </tr> <tr> <td data-bbox="421 1939 588 1980">nAnU</td> <td data-bbox="588 1939 1481 1980">Manual control</td> </tr> </table> <p>Available only when Auto/Manual control is selected in [OUT/OFF key function].</p>	AU o	Automatic control	nAnU	Manual control				
AU o	Automatic control								
nAnU	Manual control								

Characters, Factory Default	Setting Item, Function, Setting Range				
FI AE 0000	<p>Indication time</p> <ul style="list-style-type: none"> Sets time from no operation status until Displays are switched off. Displays relight by pressing any key while in Display sleep mode. When input error (Overscale, Underscale) or burnout has occurred, Displays are lit, and error codes are displayed. If errors are cancelled, Displays will be unlit after indication time has passed again. Setting range: 00:00 to 60:00 (Minutes:Seconds) When set to 00:00, Displays remain ON. 				
P4F1 □□00	<p>OUT1 MV preset value</p> <ul style="list-style-type: none"> If 'Preset output 1 ON/OFF' or 'Preset output 2 ON/OFF' is selected in [Event input allocation], OUT1 MV can be set. <p>Preset output 1 ON/OFF: If sensor is burnt out during Event Input ON, control is performed with the preset MV.</p> <p>Preset output 2 ON/OFF: When Event input is ON, control is performed with the preset MV. Setting range: OUT1 low limit to OUT1 high limit For Direct current output type, and when OUT1 is in ON/OFF control: OUT1 low limit or OUT1 high limit For Relay contact output or Non-contact voltage output type, and when OUT1 is in ON/OFF control: 0.0% or 100.0% For BCS2, available only when Event input (EIW, EIT, EI options) is ordered. For BCR2/BCD2, available when Serial communication (C5W option) or Event input (EIW, EIT, EI options) is ordered. </p>				
P4F2 □□00	<p>OUT2 MV preset value</p> <ul style="list-style-type: none"> If 'Preset output 1 ON/OFF' or 'Preset output 2 ON/OFF' is selected in [Event input allocation], OUT2 MV can be set. <p>Preset output 1 ON/OFF: If sensor is burnt out during Event Input ON, control is performed with the preset MV.</p> <p>Preset output 2 ON/OFF: When Event input is ON, control is performed with the preset MV. Setting range: OUT2 low limit to OUT2 high limit For DA, EV2+DA options, and when OUT2 is in ON/OFF control: OUT2 low limit or OUT2 high limit For DR, DS, EV2+DR, EV2+DS options, and when OUT2 is in ON/OFF control: 0.0% or 100.0% Available for the following: <ul style="list-style-type: none"> For BCS2, Heating/Cooling control [DS, DA, EV2(*1), EV2+D□ options] or Event input (EIW, EIT, EI options) is ordered. For BCR2/BCD2, Heating/Cooling control [DS, DA, EV2(*1), EV2+D□ options], Serial communication (C5W option) or Event input (EIW, EIT, EI options) is ordered. </p>				
Func cnfr	<p>Controller/Converter function</p> <ul style="list-style-type: none"> Selects either controller or converter function. Selection item: <table border="1" data-bbox="411 1937 1481 2018"> <tr> <td data-bbox="411 1937 587 1977">cnfr</td> <td data-bbox="587 1937 1481 1977">Controller</td> </tr> <tr> <td data-bbox="411 1977 587 2018">cnbf</td> <td data-bbox="587 1977 1481 2018">Converter</td> </tr> </table> <p>Available only when OUT1 is direct current output.</p>	cnfr	Controller	cnbf	Converter
cnfr	Controller				
cnbf	Converter				

(*1) When □□19 (Heating/Cooling control relay contact output) is selected in [Event output EV2 allocation].

Characters, Factory Default	Setting Item, Function, Setting Range	
<i>E d I F</i> <i>n o</i> <input type="checkbox"/>	Error indication Enabled/Disabled <ul style="list-style-type: none"> When input errors occur, the error code can be displayed (Enabled) or not displayed (Disabled). Selection item: 	
	<i>n o</i> <input type="checkbox"/>	Disabled
	<i>y E y</i> <input type="checkbox"/>	Enabled

7.4 Engineering Mode 2

To enter Engineering mode 2, press and hold the \wedge , \vee and \odot keys (in that order) together for approximately 5 seconds in RUN mode.

Use the \wedge or \vee key for settings (or selections).

To register the set data, use the \odot key.

Explanation of setting items:

- Upper left: PV Display: Indicates setting characters.
- Lower left: SV Display: Indicates factory default value.
- Right side: Indicates the setting item, explanation of its function and setting range (or selection item).

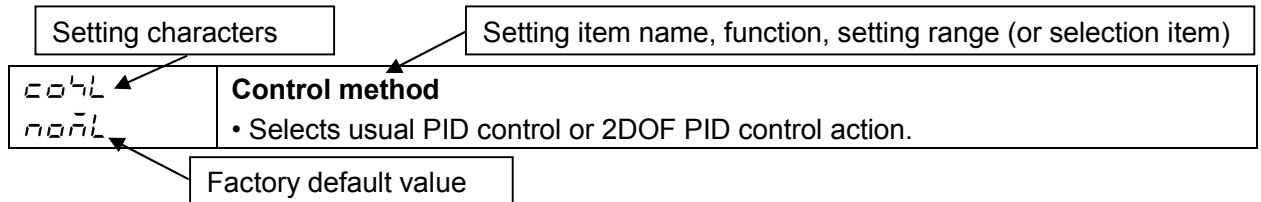

Characters, Factory Default	Setting Item, Function, Setting Range				
c07L n07L	<p>Control method</p> <ul style="list-style-type: none"> • Selects usual PID control or 2DOF PID control action. <p>DOF: Degree(s) of freedom</p> <table border="1"> <tr> <td>n07L</td> <td>PID control</td> </tr> <tr> <td>2b0F</td> <td>2DOF PID control</td> </tr> </table>	n07L	PID control	2b0F	2DOF PID control
n07L	PID control				
2b0F	2DOF PID control				
tPRH 0.40	<p>Proportional gain 2DOF coefficient (α)</p> <ul style="list-style-type: none"> • Sets Proportional gain 2DOF coefficient. <p>Increasing Proportional gain 2DOF coefficient (α) results in a quick response, and decreasing it causes a slow response.</p> <ul style="list-style-type: none"> • Setting range: 0.00 to 1.00 <p>Available only when 2DOF PID control is selected in [Control method].</p>				
I16F 1.35	<p>Integral 2DOF coefficient (β)</p> <ul style="list-style-type: none"> • Sets Integral 2DOF coefficient. <p>By increasing Integral 2DOF coefficient (β), overshoot or undershoot can be controlled more effectively.</p> <p>However, response will be slower than the usual PID control for suppressing the overshoot or undershoot.</p> <ul style="list-style-type: none"> • Setting range: 0.00 to 10.00 <p>Available only when 2DOF PID control is selected in [Control method].</p>				

2DOF PID Control

Two degree-of-freedom PID control has follow-up characteristics when SV is changed, and can suppress disturbance.

Two degree-of-freedom means that the above 2 characteristics can be adjusted independently.

Follow-up characteristics when SV is changed, can be adjusted by setting the Proportional gain 2DOF coefficient (α).

To suppress disturbance, Integral 2DOF coefficient (β) is used for adjustment.

The factory default values have been set at the optimum coefficients (α , β) for standard control.

8. Operation and Settings of Standard Functions

8.1 Selecting an input type

Select an input type in [Input type] in Initial setting mode.

Selection item:

ℓ00C	K	-200 to 1370°C	ℓ00F	K	-328 to 2498°F
ℓ0.ℓ	K	-200.0 to 400.0°C	ℓ0.F	K	-328.0 to 752.0°F
ℓ00J	J	-200 to 1000°C	ℓ00F	J	-328 to 1832°F
ℓ00R	R	0 to 1760°C	ℓ00F	R	32 to 3200°F
ℓ00S	S	0 to 1760°C	ℓ00F	S	32 to 3200°F
ℓ00B	B	0 to 1820°C	ℓ00F	B	32 to 3308°F
ℓ00E	E	-200 to 800°C	ℓ00F	E	-328 to 1472°F
ℓ0.ℓ	T	-200.0 to 400.0°C	ℓ0.F	T	-328.0 to 752.0°F
ℓ00N	N	-200 to 1300°C	ℓ00F	N	-328 to 2372°F
PL2C	PL-II	0 to 1390°C	PL2F	PL-II	32 to 2534°F
ℓ00C	C(W/Re5-26)	0 to 2315°C	ℓ00F	C(W/Re5-26)	32 to 4199°F
Pt.ℓ	Pt100	-200.0 to 850.0°C	Pt.F	Pt100	-328.0 to 1562.0°F
JPt.ℓ	JPt100	-200.0 to 500.0°C	JPt.F	JPt100	-328.0 to 932.0°F
Pt0C	Pt100	-200 to 850°C	Pt0F	Pt100	-328 to 1562°F
JPt0C	JPt100	-200 to 500°C	JPt0F	JPt100	-328 to 932°F
420A	4 to 20 mA DC	-2000 to 10000			
020A	0 to 20 mA DC	-2000 to 10000			
0.1V	0 to 1 V DC	-2000 to 10000			
0.5V	0 to 5 V DC	-2000 to 10000			
1.5V	1 to 5 V DC	-2000 to 10000			
0.10V	0 to 10 V DC	-2000 to 10000			

Factory default value is K -200 to 1370°C.

(Example) Selecting K -200.0 to 400.0°C

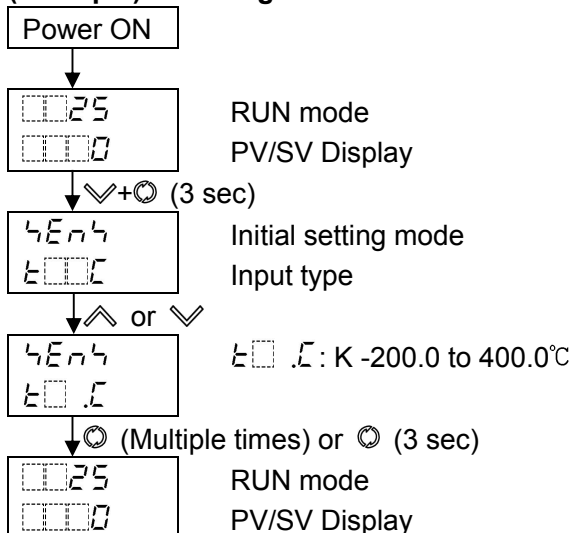

Selection is complete.

8.2 Selecting PID Control or ON/OFF Control

Selects PID control or ON/OFF control action.

Select PID control or ON/OFF control action in [OUT1 proportional band] in Sub setting mode.
If 'OUT1 proportional band' is set to 0 (zero), the unit performs ON/OFF control action.
Factory default value is PID control.

PID control

Proportional (P) action suppresses overshoot and hunting, Integral (I) action corrects offset, and Derivative (D) action adjusts for rapid temperature change due to disturbance in shorter time. Optimum values of P, I, D, ARW for PID control can be automatically set by performing AT.

ON/OFF control

When PV is lower than the SV, the control output is turned ON, and if PV exceeds the SV, the control output is turned OFF.

Overshoot, undershoot and hunting are generated in ON/OFF control action.

(Example) Selecting PID control

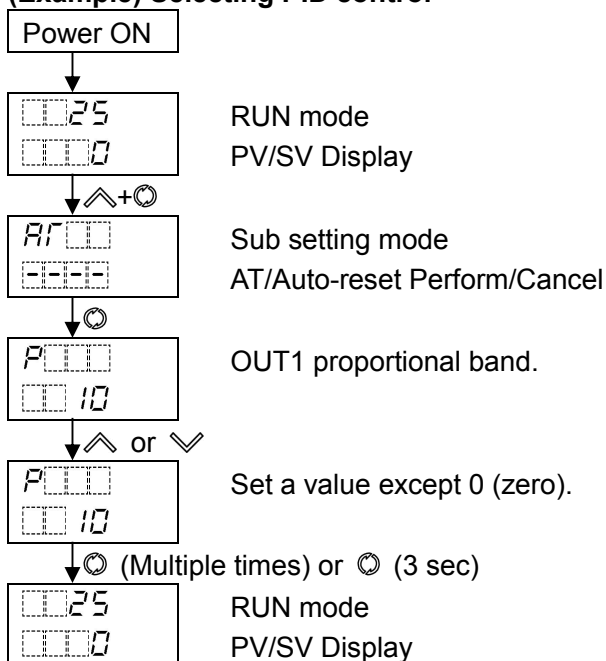

Selection is complete.

- P control action: When [Integral time] and [Derivative time] are set to 0 (zero).
- PD control action: When [Integral time] is set to 0 (zero).
- PI control action: When [Derivative time] is set to 0 (zero).
- Usual PID control or 2DOF PID control can be selected in [Control method] in Section '7.4 Engineering Mode 2' (p.78).

8.3 Selecting Direct/Reverse Action

Selects Direct or Reverse control action.

Select Direct or Reverse control action in [Direct/Reverse action] in Sub setting mode.
Factory default value is Reverse action.

Direct action

In Direct action, MV is increased when PV is higher than SV (positive deviation).
Refrigerators, etc. perform Direct action.

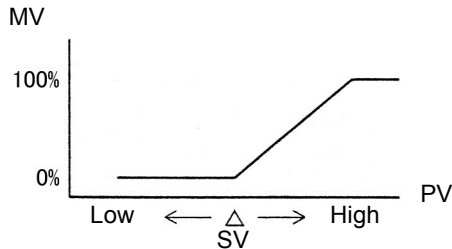

(Fig. 8.3-1)

Reverse action

In Reverse action, MV is increased when SV is higher than PV (negative deviation).
Electric furnaces, etc. perform Reverse action.

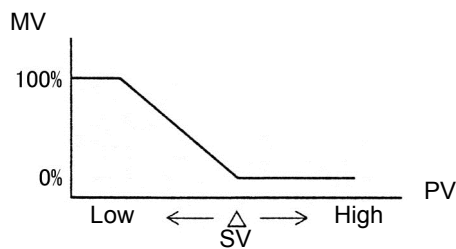

(Fig. 8.3-2)

(Example) Selecting Reverse action

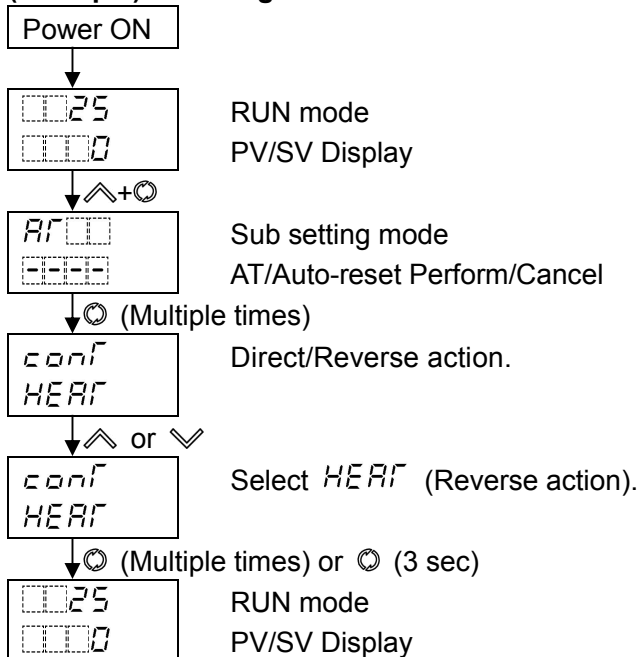

Selection is complete.

8.4 Performing Fixed Value Control

Fixed value control is a typical temperature control action, which reduces deviation from a single SV by comparing with PV.

To perform Fixed value control, set the SV.

There are 2 ways to set the SV.

- Set the SV in [SV1] in Initial setting mode.
- Set the SV in [SV1] in Main setting mode.

Setting item [SV1] in Initial setting mode corresponds to [SV1] in Main setting mode.

Therefore, if one SV1 is changed, the other SV1 will also be changed.

Factory default value is 0 (zero).

(Example) Setting SV to 100°C

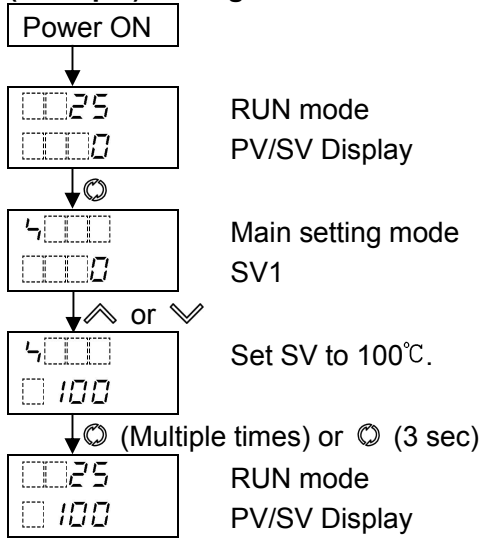

Settings are complete.

8.5 Setting PID Constants (by Performing AT)

Notice

- Perform the AT during the trial run.
- During the AT, none of the setting items can be set.
- If power failure occurs during the AT, the AT stops.
- If AT is cancelled during the process, P, I, D and ARW values revert to the values before AT was performed.
- AT will be forced to stop if it has not been completed within 4 hours.
- Sometimes the AT process will not fluctuate if AT is performed at or near room temperature. Therefore, AT might not finish normally.

To set PID constants, perform AT.

There are 2 types of AT: Usual AT and 'AT on Startup'

8.5.1 Usual AT

In order to set each value of P, I, D and ARW automatically, the AT process should be made to fluctuate to obtain an optimal value.

For DC voltage, current inputs, the AT process will fluctuate around the SV for conditions of [A], [B] and [C] below.

One of 3 types of fluctuation below is automatically selected depending on the deviation between SV and PV.

[A] If there is a large difference between the SV and PV as the temperature is rising

When AT bias is set to 20°C, the AT process will fluctuate at the temperature 20°C lower than the SV.

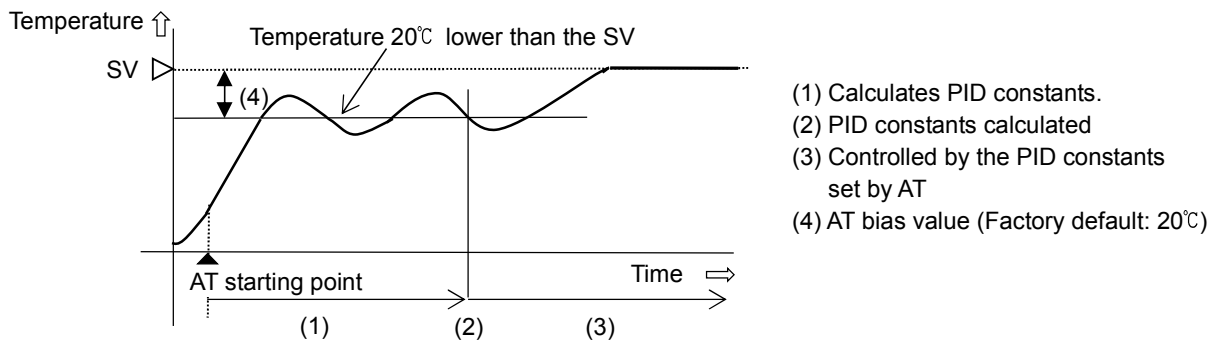

(Fig. 8.5.1-1)

[B] When the control is stable

The AT process will fluctuate around the SV.

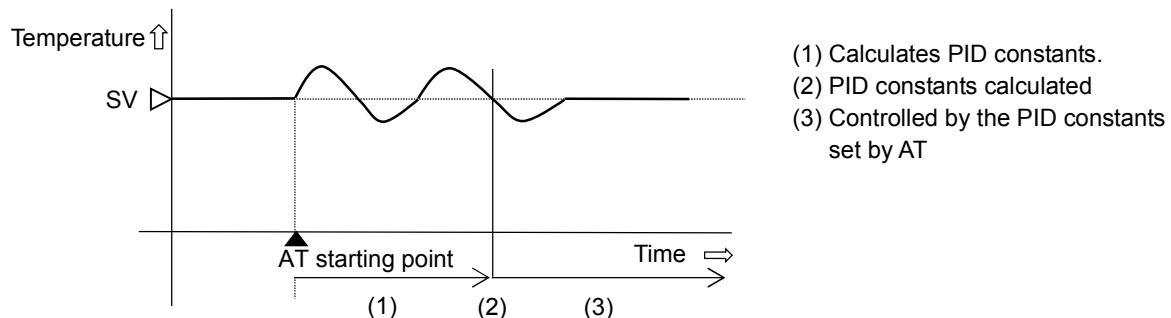

(Fig. 8.5.1-2)

[C] If there is a large difference between the SV and PV as the temperature is falling

When AT bias is set to 20°C, the AT process will fluctuate at the temperature 20°C higher than the SV.

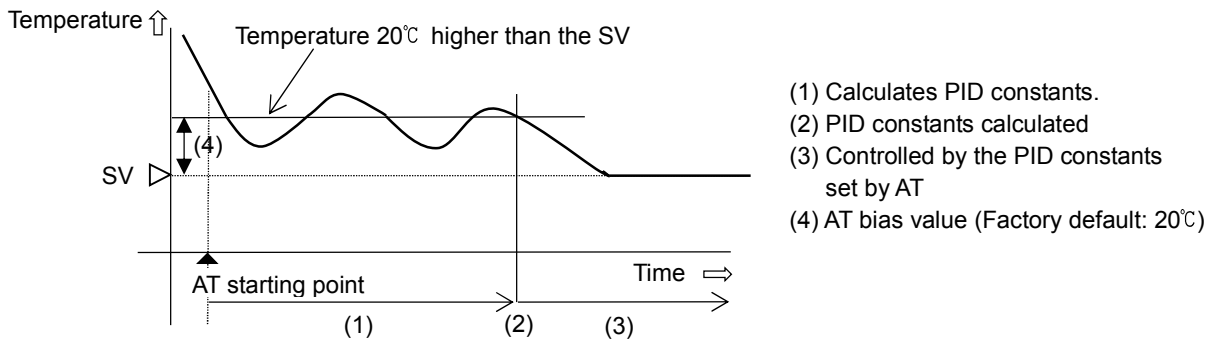

(Fig. 8.5.1-3)

8.5.2 AT on Startup

When usual AT cannot be performed normally due to temperature interference, P, I, D and ARW values can be calculated only when temperature is rising.

As the selected [AT on startup Perform] is internally memorized, 'AT on startup' is performed whenever the power is turned ON.

To stop 'AT on startup', select 'AT/AT on startup/Auto-reset Cancel' in [AT/Auto-reset Perform/Cancel].

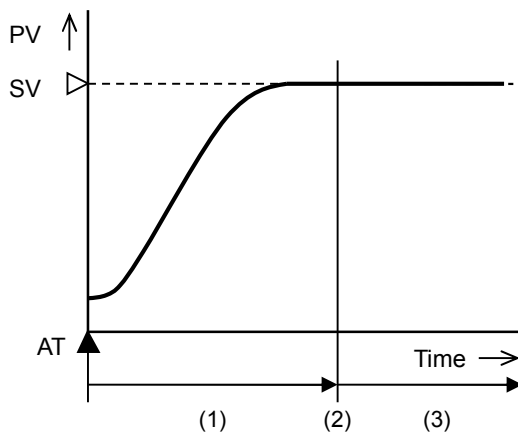

- (1) Calculates AT (from startup, until PV is stabilized at SV).
- (2) PID constants calculated
- (3) Controls with PID constants set by 'AT on startup'.

(Fig. 8.5.2-1)

[Conditions of Performing 'AT on startup']

- When starting 'AT on startup', if deviation between PV and SV exceeds the proportional band by 2 times or more, 'AT on startup' will perform.

When power is turned ON (*), or when the unit reverts to RUN mode after canceling control output OFF, 'AT on startup' performs.

Even after 'AT on startup' is successfully finished, 'AT on startup' has been still selected in [AT/Auto-reset Perform/Cancel].

When power is turned ON again, or when the unit reverts to RUN mode by cancelling Control output OFF, 'AT on startup' performs again under the above performance conditions.

To stop 'AT on startup', select 'AT/AT on startup/Auto-reset Cancel' in [AT/Auto-reset Perform/Cancel].

(*) For Fixed value control, 'AT on startup' can be performed when power is turned ON. It cannot be performed for Program control.

However, if PV slope and delay time cannot be measured normally for P, I, D calculation, the error code below will be indicated on the PV Display, and automatically 'AT on startup' will stop. If an error has occurred, P, I, D and ARW values revert to the previous value at which 'AT on startup' is performed.

Error Code	Error Contents
Er20	Normally PV slope and delay time cannot be measured for P, I, D calculation.

To cancel the error code, press the  key.

If 'AT on startup' is performed or stopped again, the error code will be cancelled.

[Conditions of Cancelling 'AT on startup']

- When Control output OFF is enabled
- When input is burnt out
- When deviation between SV and PV is not within 2°C or is not within 2% of proportional band (even though the set integral time has elapsed when the control is stable) in stable control status

(Example) Performing Usual AT

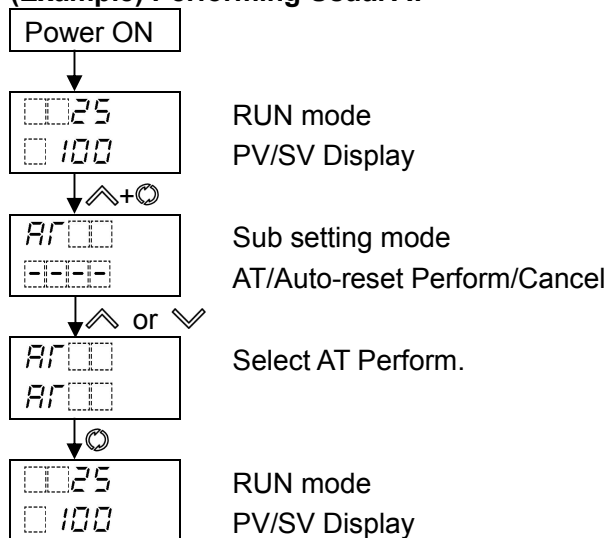

Selection is complete.

The AT indicator flashes while AT is performing.

After AT is complete, the AT indicator turns off, and control is performed using PID constants calculated by the AT.

If AT does not finish after 4 hours, the error code below will be indicated on the PV Display, and AT will automatically stop.

Error Code	Error Contents
Er20	If AT or 'AT on startup' does not finish after 4 hours.

To cancel the error code, press the  key.

The error code will be cancelled in the following cases.

- When Control output OFF function is enabled
- When Program control is stopped and the unit reverts to Standby (Program control waiting) mode.
- When 'Control output OFF function' or 'Auto/Manual control' is selected in [OUT/OFF key function].
- When 'AT/AT on startup/Auto-reset Cancel' is selected in [AT/Auto-reset Perform/Cancel].

8.6 Performing Auto-reset

Notice

- Auto-reset finishes in approximately 4 minutes. It cannot be cancelled while performing this function.
- If input is burnt out, Auto-reset will be forced to stop.

In PD control, Auto-reset is performed to correct the offset at the point at which PV indication is stabilized within the proportional band. Since the corrected value is internally memorized, it is not necessary to perform the Auto-reset again as long as the process is the same. However, when OUT1 proportional band (P) is set to 0 or 0.0, the corrected value is cleared to 0 (zero).

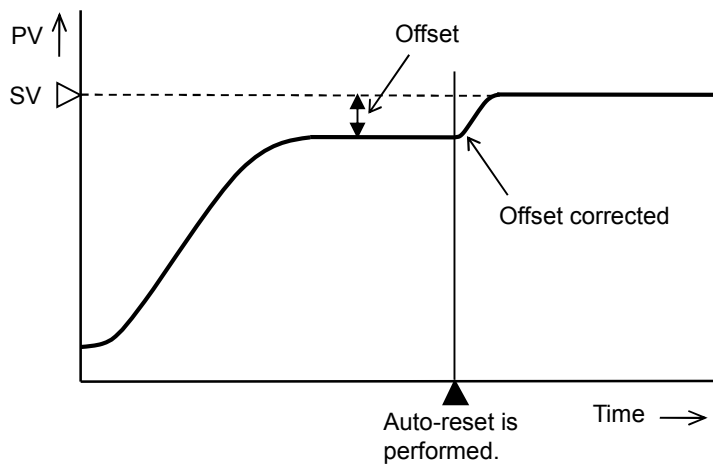

(Fig. 8.6-1)

(Example) Performing Auto-reset

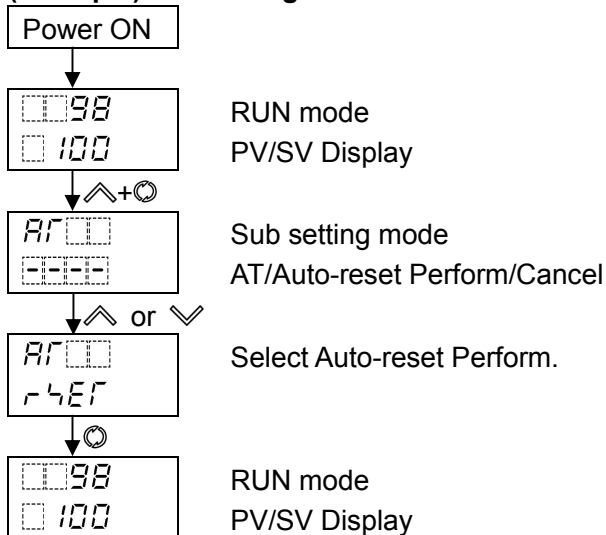

Selection is complete.

The AT indicator flashes while Auto-reset is performing.

Auto-reset is completed in approximately 4 minutes.

After Auto-reset is complete, the AT indicator turns off, and control is performed using the offset corrected value.

8.7 Performing Program Control

In Program control, SV changes as time elapses, and PV is controlled in order to reach each SV. SV and time can be set for every step, and a maximum of 9 steps can be repeatedly controlled. SV can be set as (Fig. 8.7-1).

(e.g.) Program control of electric furnaces in ceramic manufacture, food machinery, etc.

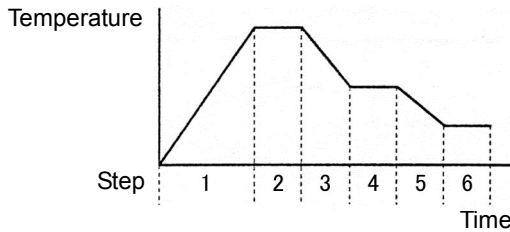

(Fig. 8.7-1)

Major functions of Program control are shown below.

Number of patterns and steps: 1 pattern; 9 steps

Wait function

While Program control is running, the program does not proceed to the next step until the deviation between PV and SV enters $SV \pm \text{Wait}$ value at the end of step. The PV Display flashes while the Wait function is working.

The Wait function is cancelled on the condition that:

- When program pattern is rising: PV is higher than $SV - \text{Wait}$ value
- When program pattern is falling: PV is lower than $SV + \text{Wait}$ value

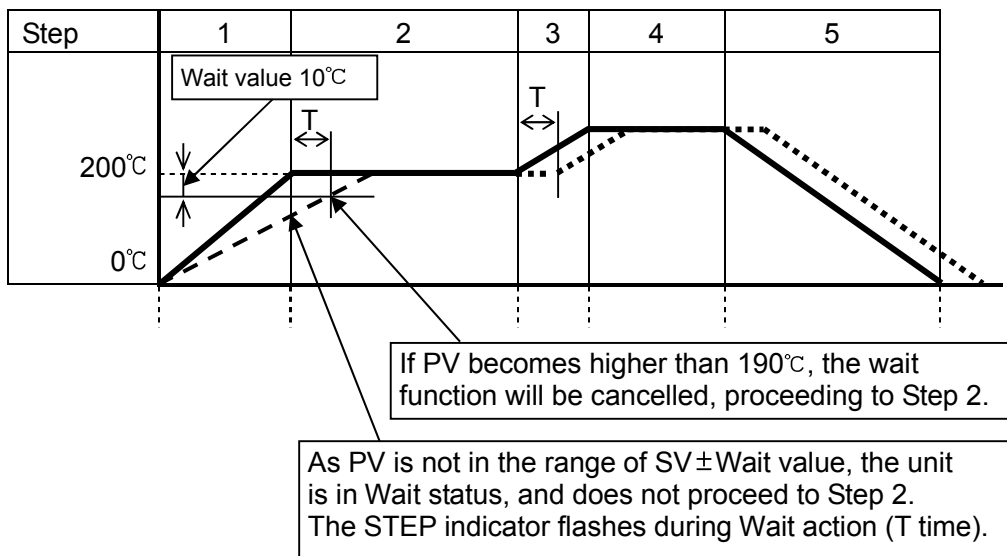

----- : PV

————— : Program pattern

..... : Program pattern delayed by T due to the Wait function

(Fig. 8.7-2)

Program control Holding/Not holding

During Program control, progress of current step is suspended, and then Fixed value control is performed using the SV from the point of suspension. Program control Holding/Not holding can be selected in [Event input DI1/DI2 allocation].

Advance function

Interrupts current step while Program control is running, and proceeds to the beginning of the next step.

By pressing the \curvearrowright key for approx. 1 second during Program control, Advance function initiates. Select this function in [Event input DI1/DI2 allocation].

Pattern end output

If Pattern end output is selected in [Event output EV1/EV2 allocation], pattern end output is turned ON after Program control is finished, and the SV Display flashes *P.E n d.*

By pressing the \odot key for approx. 1 second, pattern end output is turned OFF, and the unit enters Standby mode.

Step time unit

Step time unit can be selected: Hours:Minutes, Minutes:Seconds

Factory default value is Hours:Minutes.

Power Restore Action (Program control after power is restored)

If power fails during Program control, selects a status after the power is restored.

Factory default value is 'Stops after power is restored'.

Power Restore Action	Description
Stops after power is restored.	Stops Program control, and returns to Standby (Program control waiting) mode.
Continues after power is restored. (*)	Continues (resumes) Program control.
Suspends after power is restored. (*)	Suspends (on hold) current program, and performs Fixed value control using the SV from the point of suspension. Pressing the \odot key cancels suspension, and Program control resumes.

(*) Progressing time error when power is restored: 10 minutes

This controller saves internal status every 10 minutes after Program control starts.

Internal status is also saved when step is changed.

When power is restored, the unit starts from the last auto-save point.

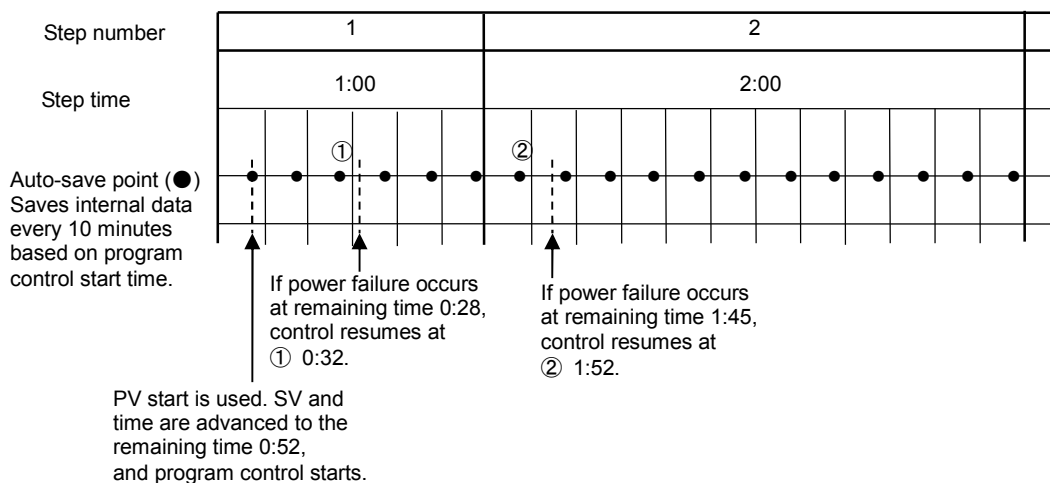

(Fig. 8.7-3)

Program start temperature

When Program control starts, it starts from the value set in [Program start temperature].
 Factory default value is 0°C.

Program control start type

One type can be selected: PV start, PVR start, SV start.
 Factory default value is PV start.

Program control start type	Description
PV start	When Program control starts, the SV and step time are advanced to the PV, then Program control starts. However, if [Program start temperature] at the time of Program control start is higher than the PV (when PV start is initiated), then Program control will start from the SV set in [Program start temperature].
PVR start	In pattern repeating, the SV and step time are advanced to the PV, then the Program control starts.
SV start	Program control starts from the SV which has been set in [Program start temperature].

[SV start]

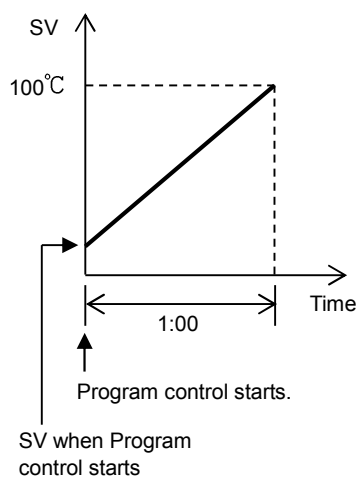

(Fig. 8.7-4)

[PV/PVR start]

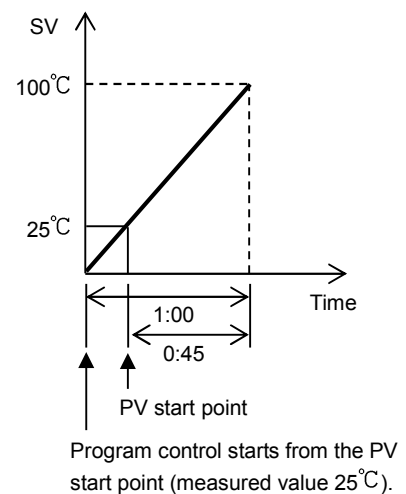

(Fig. 8.7-5)

Repeat function

When Program control is finished, control can be repeated from Step 1.
 The user determines the number of repetitions.
 Factory default value is 0 (zero).

Select 'Program control' in [OUT/OFF key function] in Engineering mode 1.
 Factory default value is Control output OFF function.

Set the following items in Engineering mode 1:

- Step time unit, Power restore action, Program start temperature,
- Program control start type, Number of repetitions

Program pattern can be set in Main setting mode.

Example of program pattern setting

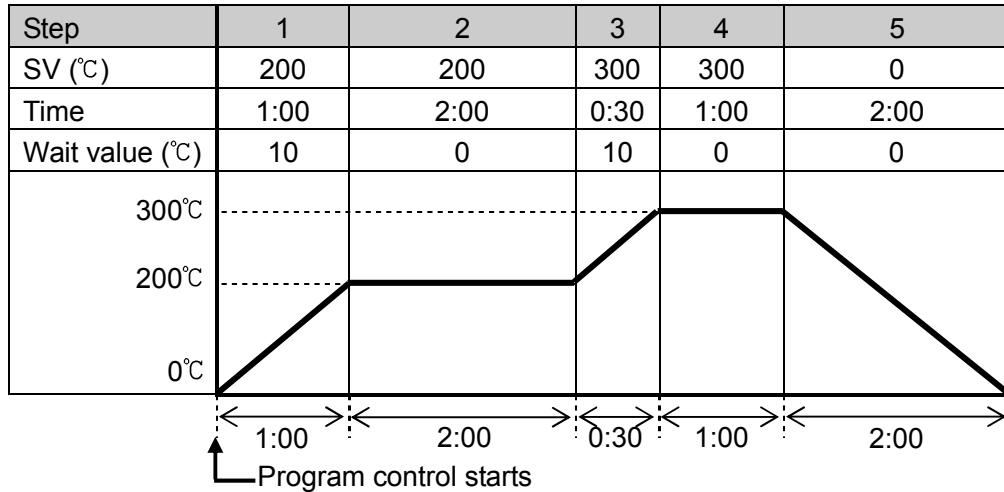

(Fig. 8.7-6)

In the above program pattern, control is performed at each step as follows.

Step 1: The SV gradually rises to 200°C for 1 hour.

When the step ends, Wait function works so that control cannot proceed to the next step until PV reaches 190°C when step ends.

Step 2: Fixed value control is performed to keep SV at 200°C for 2 hours.

Step 3: Control is performed so that the SV gradually rises to 300°C for 30 minutes.

When the step is finished, Wait function works so that control cannot proceed to the next step until PV reaches 290°C.

Step 4: Fixed value control is performed to keep SV at 300°C for 1 hour.

Step 5: Control is performed so that the SV gradually falls to 0°C for 2 hours.

(Example) Selecting Program control and Setting program pattern of (Fig. 8.7-6)

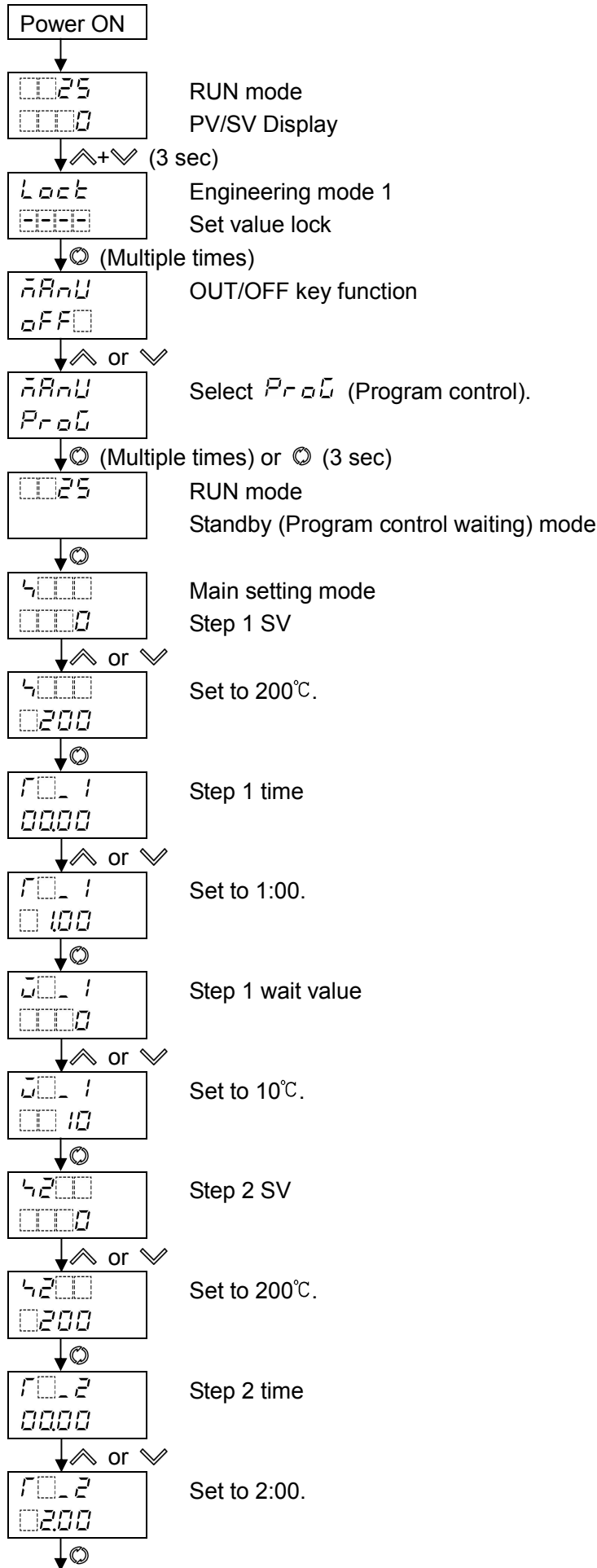

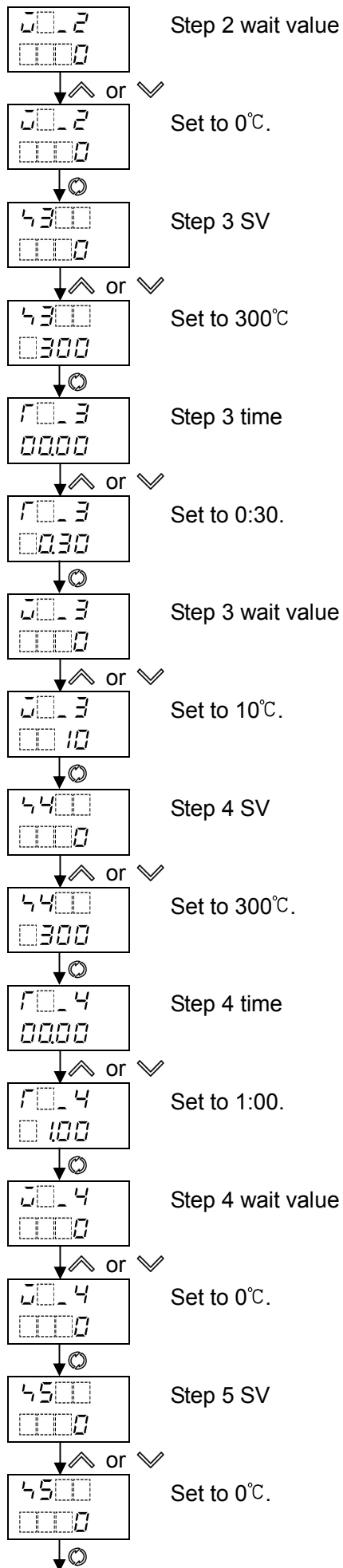

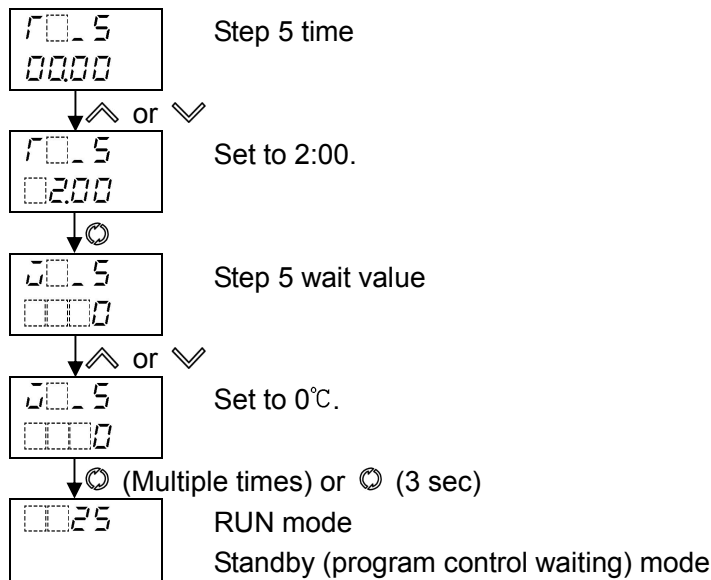

Selection is complete.

Program control RUN

To perform Program control, press and hold the @ key for approx. 1 second in Standby (program control waiting) mode.

Program control starts using the start type selected in [Program control start type].

While Wait function is working, the PV Display flashes.

Program control STOP

To stop Program control, press and hold the @ key for approx. 1 second during Program control. Program control will stop, and the unit will revert to Standby (Program control waiting) mode.

Proceeding to the next step during Program control (Advance function)

By pressing the ^ key for approx. 1 second during Program control, the performing step is interrupted, proceeding to the next step. (Advance function)

While Wait function is working, the Wait function is cancelled, and proceeds to the next step.

If 0008 (Program control RUN/STOP) is selected in [Event input DI1 allocation], Program control RUN/STOP can be switched by terminals 17 and 18 [DI1-COM]:

Signal edge action from OFF to ON / ON to OFF is engaged.

However, for the action when power is turned ON, Level action [ON (Closed) or OFF (Open)] is engaged.

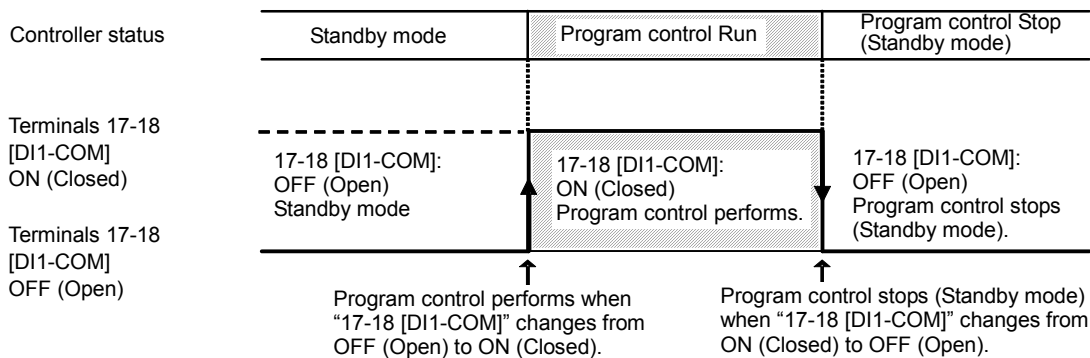

(Fig. 8.7-7)

8.8 Event Output EV1 Allocation

Selects Event output EV1 allocation.

There are 2 methods in selection of Event output EV1 allocation.

- Select in [Event output EV1 allocation] in Initial setting mode.
- Select in [Event output EV1 allocation] in Engineering mode 1.

Setting item [Event output EV1 allocation] in Initial setting mode corresponds to [Event output EV1 allocation] in Engineering mode 1.

Therefore, if one [Event output EV1 allocation] is changed, the other [Event output EV1 allocation] will also be changed.

Factory default value is No event.

Selection item:

<input type="checkbox"/> 000	No event	
<input type="checkbox"/> 001	Alarm output, High limit alarm	
<input type="checkbox"/> 002	Alarm output, Low limit alarm	
<input type="checkbox"/> 003	Alarm output, High/Low limits alarm	
<input type="checkbox"/> 004	Alarm output, High/Low limits independent alarm	
<input type="checkbox"/> 005	Alarm output, High/Low limit range alarm	
<input type="checkbox"/> 006	Alarm output, High/Low limit range independent alarm	
<input type="checkbox"/> 007	Alarm output, Process high alarm	
<input type="checkbox"/> 008	Alarm output, Process low alarm	
<input type="checkbox"/> 009	Alarm output, High limit with standby alarm	
<input type="checkbox"/> 010	Alarm output, Low limit with standby alarm	
<input type="checkbox"/> 011	Alarm output, High/Low limits with standby alarm	
<input type="checkbox"/> 012	Alarm output, High/Low limits with standby independent alarm	
<input type="checkbox"/> 013	Heater burnout alarm output	
<input type="checkbox"/> 014	Loop break alarm output	
<input type="checkbox"/> 015	Time signal output	Turns OFF or ON during Program control, by setting OFF time and ON time within the step set in [Step number].
<input type="checkbox"/> 016	Output during AT	Turns ON during AT.
<input type="checkbox"/> 017	Pattern end output	Turns ON when Program control ends, and remains ON until turned OFF by pressing the $\text{\textcircled{C}}$ key.
<input type="checkbox"/> 018	Output by communication command	Turns OFF or ON by communication command 00E4H during Serial communication. B0 EV1 output 0: OFF 1: ON B1 EV2 output 0: OFF 1: ON

(Example) Selecting High limit alarm, and setting EV1 alarm value to 20°C

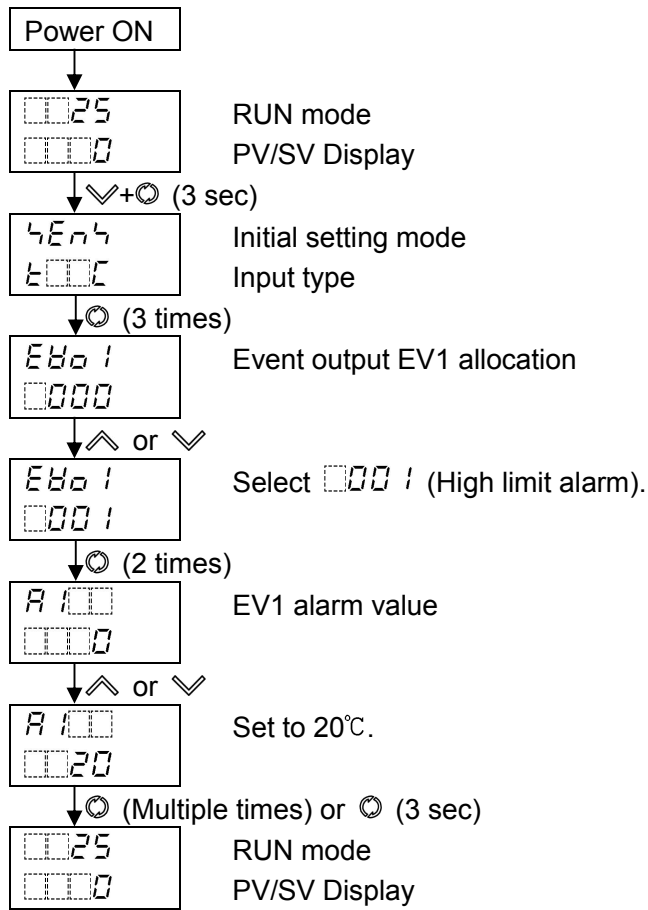

Settings are complete.

8.9 Indicating MV, Remaining Time (Program Control)

In Fixed value control and Program control, MV and remaining time are indicated.

To indicate MV, press and hold the  key for approx. 3 seconds on the PV/SV Display.

The unit enters Monitor mode, and indicates MV.

While MV is indicating, the decimal point flashes.

While in Standby (Program control waiting) mode of Program control, the unit cannot move to Monitor mode.

In Monitor mode, the following contents are switched every time the  key is pressed.

Model	Indicated Contents	
BCS2	Fixed value control	Indicates MV, Set value memory number (in that order).
	Program control	Indicates MV, Remaining time, Step number (in that order).
BCR2, BCD2	Fixed value control	Indicates only MV. (*)
	Program control	Indicates MV, Remaining time (in that order). (*)

(*) For the BCR2, BCD2, Set value memory number (Fixed value control) and step number (Program control) are indicated on the MEMO/STEP Display.

Indicating MV, Remaining time

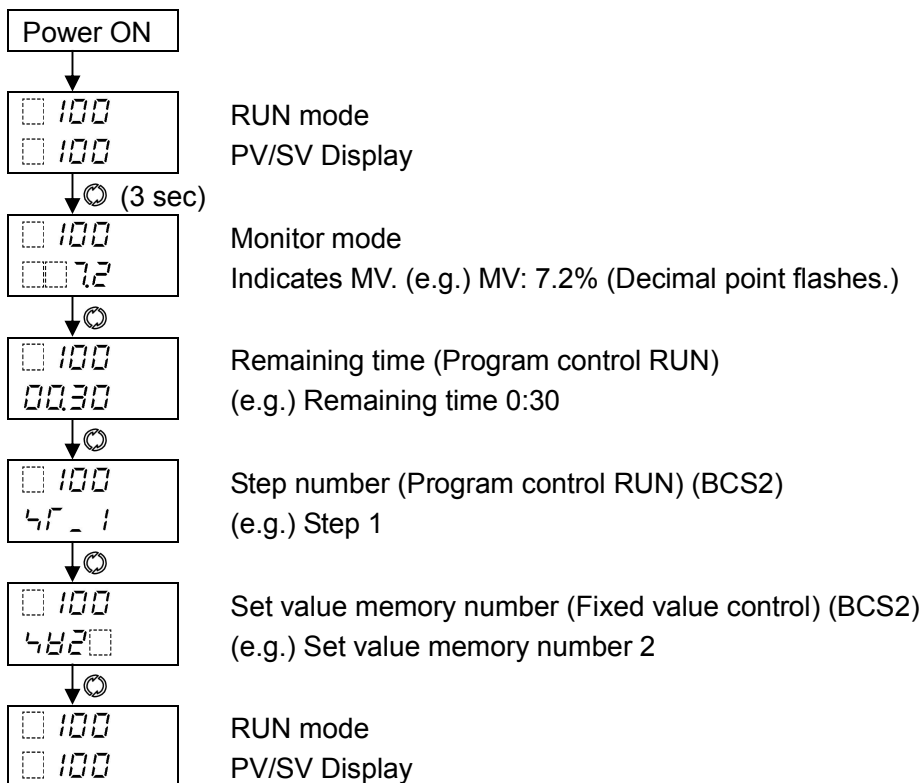

8.10 Items to be Initialized by Changing Settings

If settings are changed, the following items will be initialized.

●: Initialized

X: Not initialized

Item to be initialized \ Setting item to be changed	Input Type	Event output EV1 allocation	Event output EV2 allocation	Transmission output
SV1 to SV9	●	X	X	X
Steps 1 to 9 wait value	●	X	X	X
AT bias	●	X	X	X
OUT1 proportional band	●	X	X	X
Manual reset	●	X	X	X
SV rise rate	●	X	X	X
SV fall rate	●	X	X	X
Scaling high limit	●	X	X	X
Scaling low limit	●	X	X	X
Program start temperature	●	X	X	X
EV1 alarm value	●	●	X	X
EV1 high limit alarm value	●	●	X	X
Loop break alarm time	●	X	X	X
Loop break alarm span	●	X	X	X
SVTC bias	●	X	X	X
Remote bias	●	X	X	X
EV2 alarm value	●	X	●	X
EV2 high limit alarm value	●	X	●	X
Transmission output high limit (Except MV transmission)	●	X	X	●
Transmission output low limit (Except MV transmission)	●	X	X	●
OUT2 proportional band	●	X	X	X
EV1 alarm value 0 Enabled/Disabled	X	●	X	X
EV1 alarm hysteresis	X	●	X	X
EV1 alarm delay time	X	●	X	X
EV1 alarm Energized/De-energized	X	●	X	X
EV2 alarm value 0 Enabled/Disabled	X	X	●	X
EV2 alarm hysteresis	X	X	●	X
EV2 alarm delay time	X	X	●	X
EV2 alarm Energized/De-energized	X	X	●	X
Sensor correction coefficient	●	X	X	X
Sensor correction	●	X	X	X
External setting input high limit	●	X	X	X
External setting input low limit	●	X	X	X

9. Attached Function

9.1 Input Value Correction

Input value can be corrected in [Sensor correction coefficient] and [Sensor correction] in Engineering mode 1.

In [Sensor correction coefficient], set the slope of temperature change.

In [Sensor correction], set the difference between temperatures before correction and after correction.

PV after input correction is expressed by the following formula.

PV after input correction = Current PV x Sensor correction coefficient + (Sensor correction value)

The following shows an example of input value correction using 'Sensor correction coefficient' and 'Sensor correction value'.

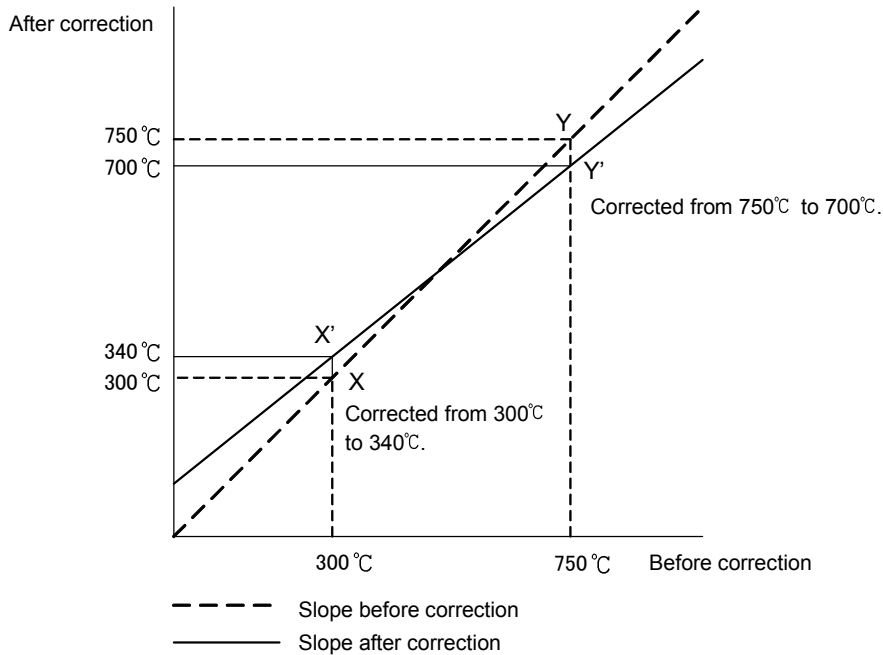

(Fig.9.1-1)

- (1) Select any 2 points of PV to be corrected, and determine the PV after correction.
PV before correction: 300°C → PV after correction: 340°C
PV before correction: 750°C → PV after correction: 700°C
- (2) Calculate Sensor correction coefficient from Step (1).
 $(Y' - X') / (Y - X) = (700 - 340) / (750 - 300) = 0.8$
- (3) Enter a PV value of 300°C using an mV generator or dial resistor.
- (4) Set Step (2) value as a Sensor correction coefficient.
- (5) Read the PV.
240°C will be indicated.
- (6) Calculate the sensor correction value.
Calculate the difference between 'PV after correction' and Step (5) PV.
 $340°C - 240°C = 100°C$
- (7) Set Step (6) value as a Sensor correction value.
- (8) Enter an electromotive force or resistance value equivalent to 750°C using an mV generator or dial resistor.
- (9) Read the PV, and confirm that 700°C is indicated.

(Example) Setting Sensor correction coefficient to 0.800, and Sensor correction to 100.0°C

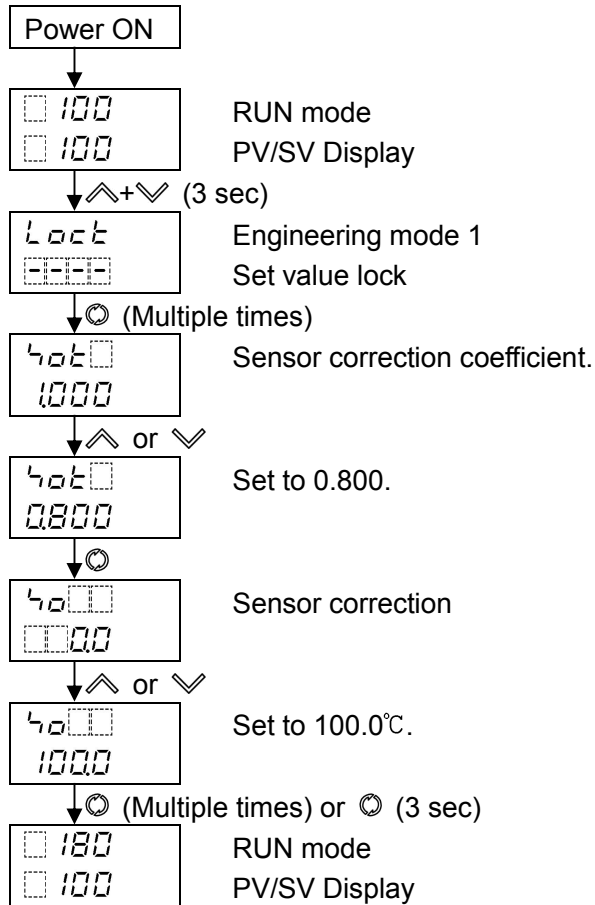

Settings are complete.

9.2 Set Value Lock

Locks the set values to prevent setting errors.

Make a selection in [Set value lock] in Engineering mode 1.

The setting item to be locked depends on the selection.

Selection Item	Change via Keypad	Change via Software Communication
Unlock	All set values can be changed.	All set values can be changed.
Lock 1	None of the set values can be changed.	
Lock 2	In Fixed value control, only SV and Alarm value can be changed. In Program control, Step SV, Step time and Alarm value can be changed.	Setting items – except Input type, Controller/Converter – can be changed temporarily via software communication. However, if power is turned ON again, the setting values revert to the values before Lock 3, 4 or 5 was selected.
Lock 3	All set values can be changed.	
Lock 4	None of the set values can be changed.	
Lock 5	In Fixed value control, only SV and Alarm value can be changed. In Program control, Step SV, Step time and Alarm value can be changed.	

(Example) Selecting Lock 2

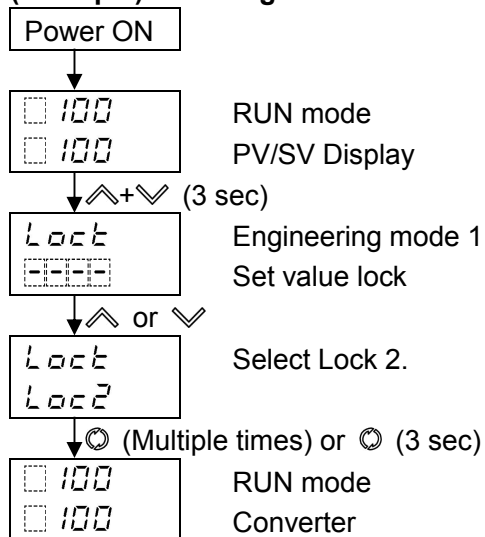

Selection is complete.

9.3 Control Output OFF Function

The control action and output of an instrument (or instruments) can be turned OFF without turning OFF their power supplies using this function.

Select 'Control output OFF function' in [OUT/OFF key function] in Engineering mode 1.
Factory default value is Control output OFF function.

(Example) Selecting 'Control output OFF function', and 'PV indication' in [Indication when control output OFF]

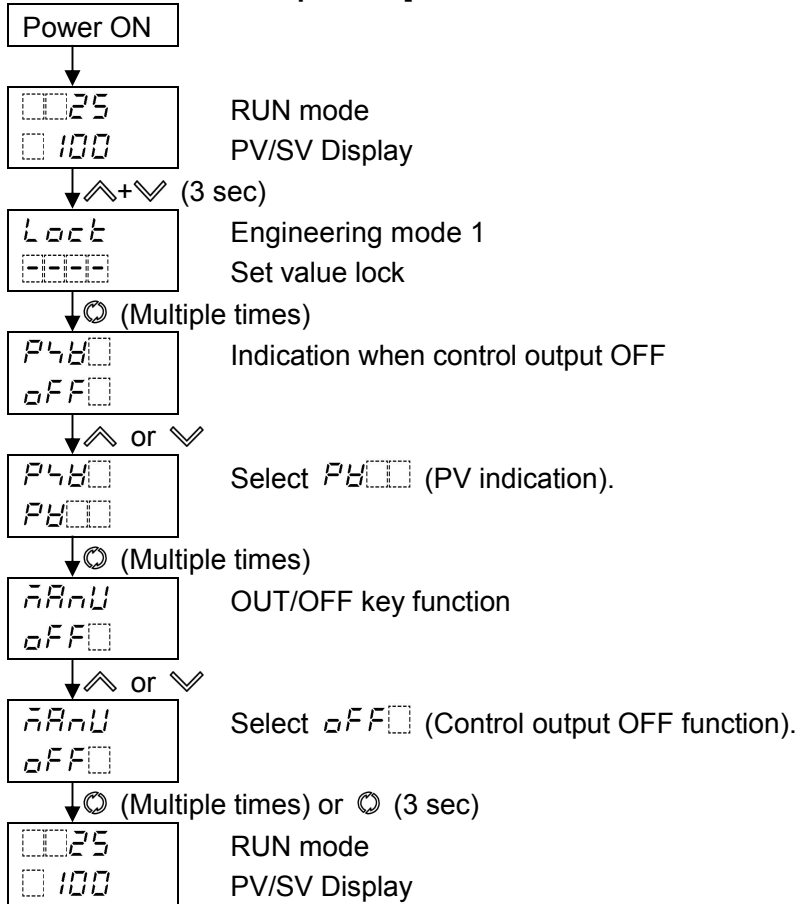

Selection is complete.

To turn the control output OFF, press the \odot key for approximately 1 second on the PV/SV Display. PV is indicated on the PV Display. Indication differs depending on the selection in [Indication when control output OFF].

Once the control output OFF function is enabled, the function cannot be cancelled even if the power to the instrument is turned OFF and ON again.

To cancel the function, press the \odot key again for approx. 1 second.

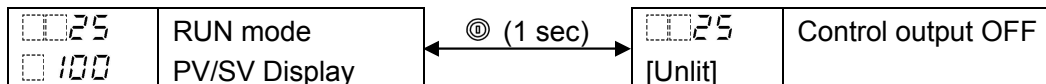

9.4 Switching Auto/Manual Control (Auto/Manual Control Function)

Control action can be switched from automatic to manual and vice versa.

When power to the controller is turned ON, Automatic or Manual control is selectable.

Select 'Auto/Manual control' in [OUT/OFF key function] in Engineering mode 1.

Factory default value is Control output OFF function.

Select 'Automatic control' or 'Manual control' in [Auto/Manual control after power ON] in Engineering mode 1.

Factory default value is Automatic control.

(Example) Selecting 'Auto/Manual control' and 'Manual control' after power ON

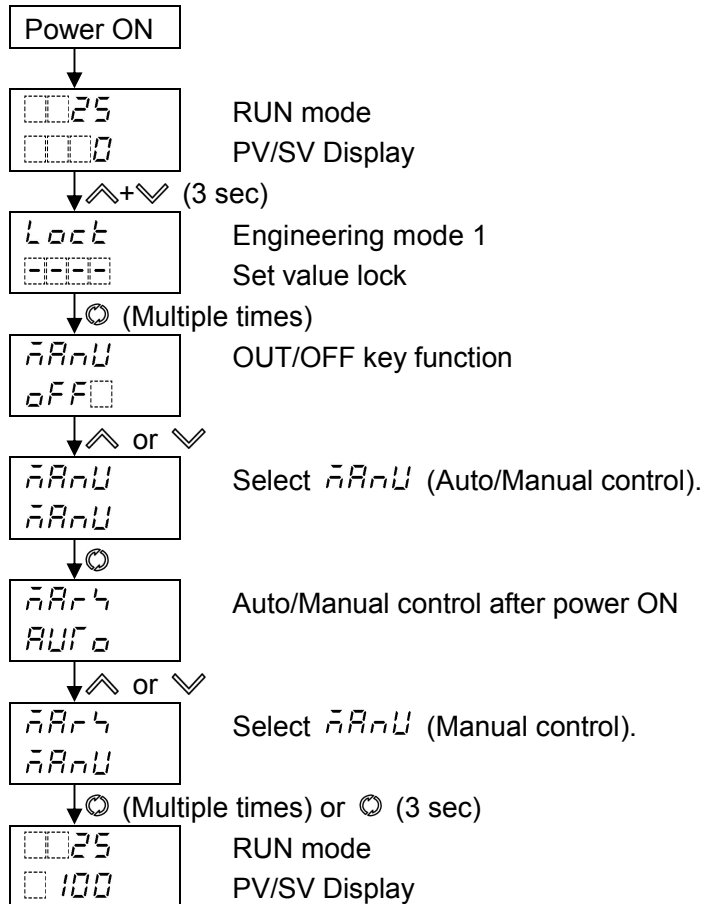

Selection is complete.

By pressing the \odot key in PV/SV Display for approx. 1 second, Auto/Manual control function can be switched.

If control action is switched from automatic to manual and vice versa, balanceless-bumpless function works to prevent a sudden change in the MV.

When automatic control is switched to manual control, MV flashes on the SV Display.

The MV on the SV Display can be increased or decreased by pressing the \wedge or \vee key.

Data is saved 1 second after MV is changed, and manual control is performed.

If Manual control is selected in [Auto/Manual control after power ON: When power is turned ON, control resumes using the previously saved MV.

However, if 0005 (Auto/Manual control) is selected in [Event input DI1/DI2 allocation], then Event input status has priority.

By pressing the \odot key again for approx. 1 second, the unit reverts to automatic control.

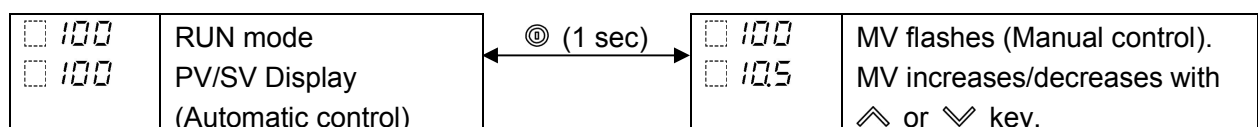

9.5 Using as a Converter



Caution

Input/Output response time of this instrument is approx. 1 second.
When using as a converter, the converter input will be 1 sec slower due to the response time.
(In such cases please use a converter with input time slower than the response time above.)

This instrument can be used as a simplified converter.

Converts each input value (thermocouple, RTD, DC voltage and current inputs) to '4 to 20 mA DC', and outputs it.

When OUT1 is direct current output type, the controller can be used as a converter.

Select 'Converter' in [Controller/Converter] in Engineering mode 1.

Factory default value is 'Controller'.

When this instrument is switched from controller to converter, values in the table below (Table 9.5-1) are automatically set. The SV Display turns blank.

When this instrument is switched from converter to controller, the PV Display indicates $\bar{}$ for 1 second, and factory default values are set.

(Table 9.5-1)

Setting Item	Set Value (or Selection)
SV1 (*1)	Scaling low limit value
SV2 (*1) (BCS2: EIW, EIT, EI options, BCR2/BCD2: C5W, EIW, EIT, EI options)	Scaling low limit value
SV3 (*1) (BCS2: EIW, EI options, BCR2/BCD2: C5W, EIW, EIT, EI options)	Scaling low limit value
SV4 (*1) (BCS2: EIW, EI options, BCR2/BCD2: C5W, EIW, EIT, EI options)	Scaling low limit value
AT/Auto-reset Perform/Cancel (*2)	AT/AT on startup/Auto-reset Cancel
OUT1 proportional band (*1)	Scaling span
Integral time	0
Derivative time	0
Reset (*3)	0 (Initialized) (Reset value, calculated by Auto-reset function)
OUT1 high limit	100
OUT1 low limit	0
OUT1 rate-of-change	0
OUT2 proportional band (*1)	Scaling span
Direct/Reverse action	Direct action
EV1/EV2 alarm value 0 Enabled/Disabled	Disabled
EV1/EV2 alarm value	0 or Input range low limit value (Scaling low limit value)
EV1/EV2 high limit alarm value	0 or Input range low limit value (Scaling low limit value)
EV1/EV2 alarm hysteresis	1.0 (DC voltage, current input: The placement of the decimal point follows the selection.)
EV1/EV2 alarm delay time	0
EV1/EV2 alarm Energized/De-energized	Energized

(*1) When input range is changed while this instrument is used as a converter, SV1 to SV4, OUT1 and OUT2 proportional bands will be automatically set to values corresponding to the input range.

(*2) If "AT on startup" is successfully completed and "AT on startup Perform" has been still selected, "AT on startup" will be stopped (AT/ AT on startup/Auto-reset Cancel).

(*3) The reset value calculated by Auto-reset function will be initialized.

Setting Item	Set Value (or Selection)
Loop break alarm time	0
Loop break alarm span	0
Event input DI1 allocation (BCS2: EIW, EIT, EI options, BCR2/BCD2: C5W, EIW, EIT, EI options)	No event
Event input DI2 allocation (BCS2: EIW, EI options, BCR2/BCD2: C5W, EIW, EIT, EI options)	No event
Event output EV1 allocation	No event
Event output EV2 allocation (EV2, EV2+D□ options)	No event
Remote/Local (EIT option)	Local
Transmission output type (EIT option)	PV transmission
Transmission output high limit (EIT option)	Input range high limit
Transmission output low limit (EIT option)	Input range low limit
SV rise rate	0
SV fall rate	0
OUT/OFF key function	Control output OFF function

9.5.1 Selecting Converter Function

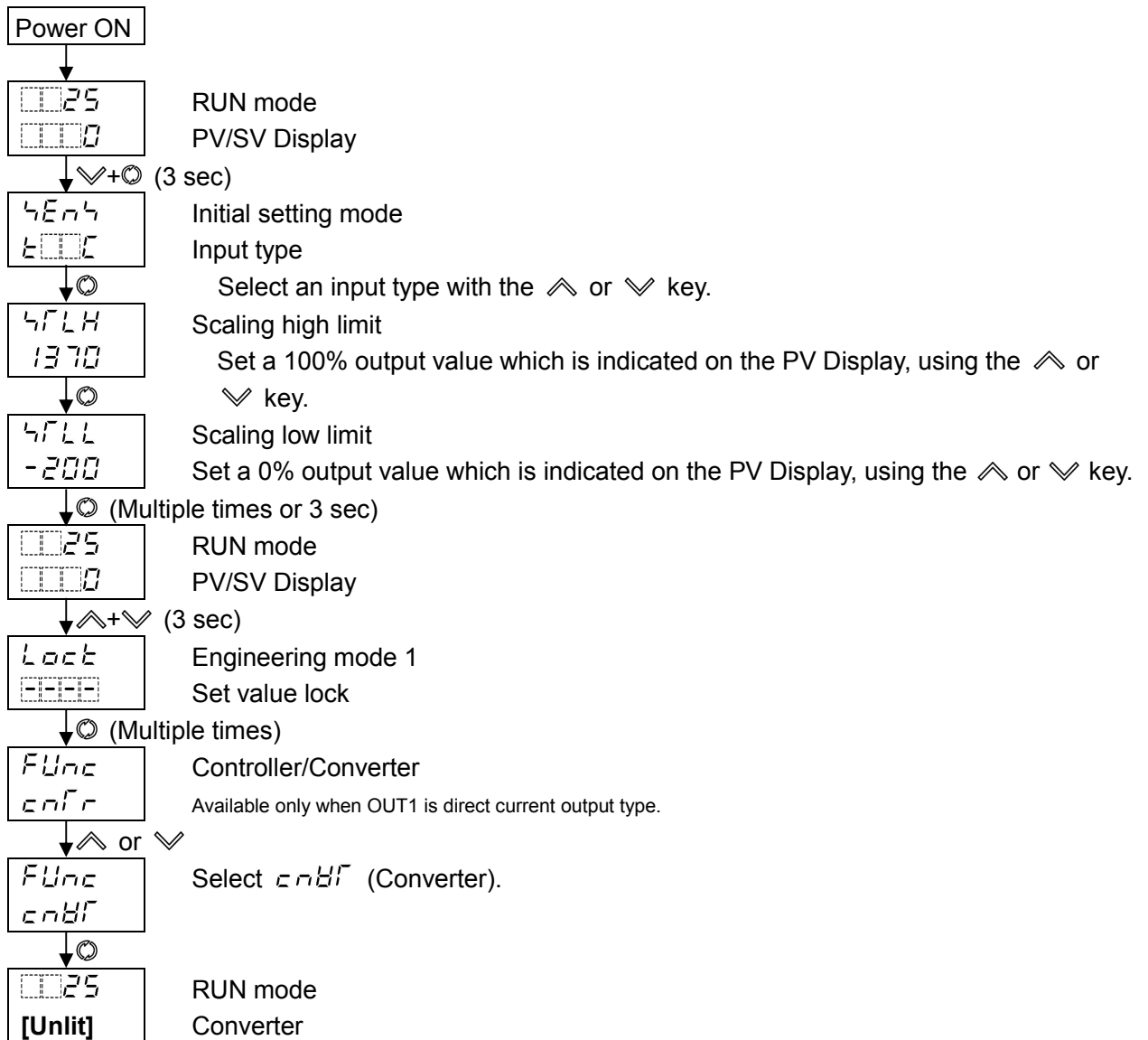

Selection is complete.

9.5.2 Fine Adjustment of Converter Output (4 to 20 mA DC)

4 to 20 mA DC will be output corresponding to the input from Scaling low limit to Scaling high limit.

Fine adjustment range: 1/Scaling span

Fine Adjustment Method for Converter Output

Be sure to perform Zero side first in fine adjustment of converter output.

Perform Zero side adjustment in [Manual reset].

Perform Span side adjustment in [OUT1 proportional band].

(1) Adjust Zero side.

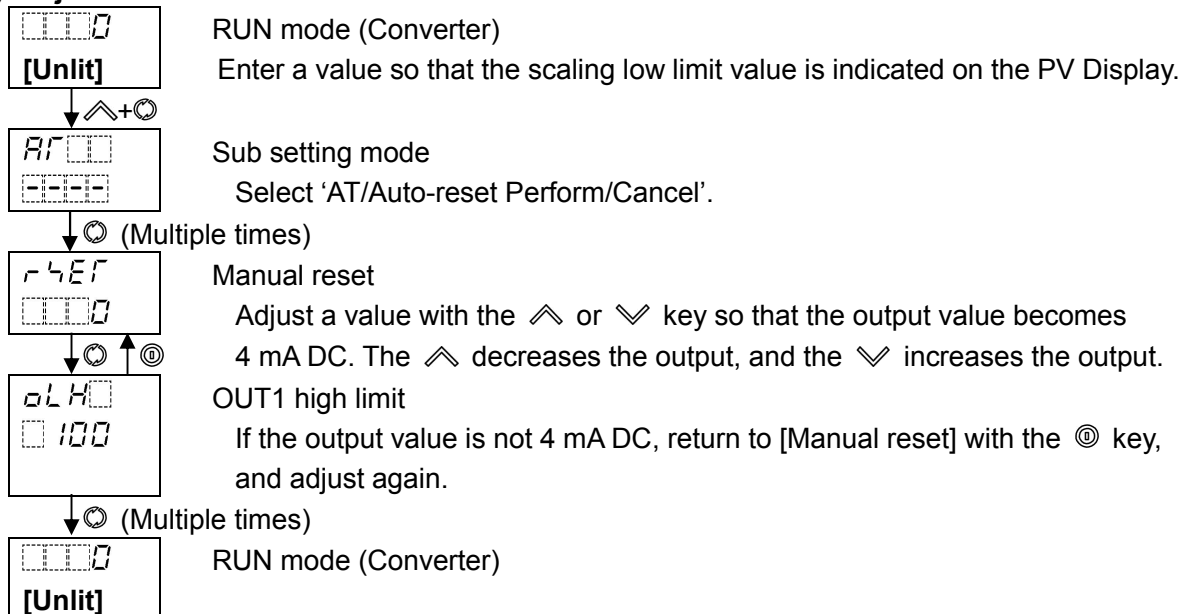

(2) Adjust Span side.

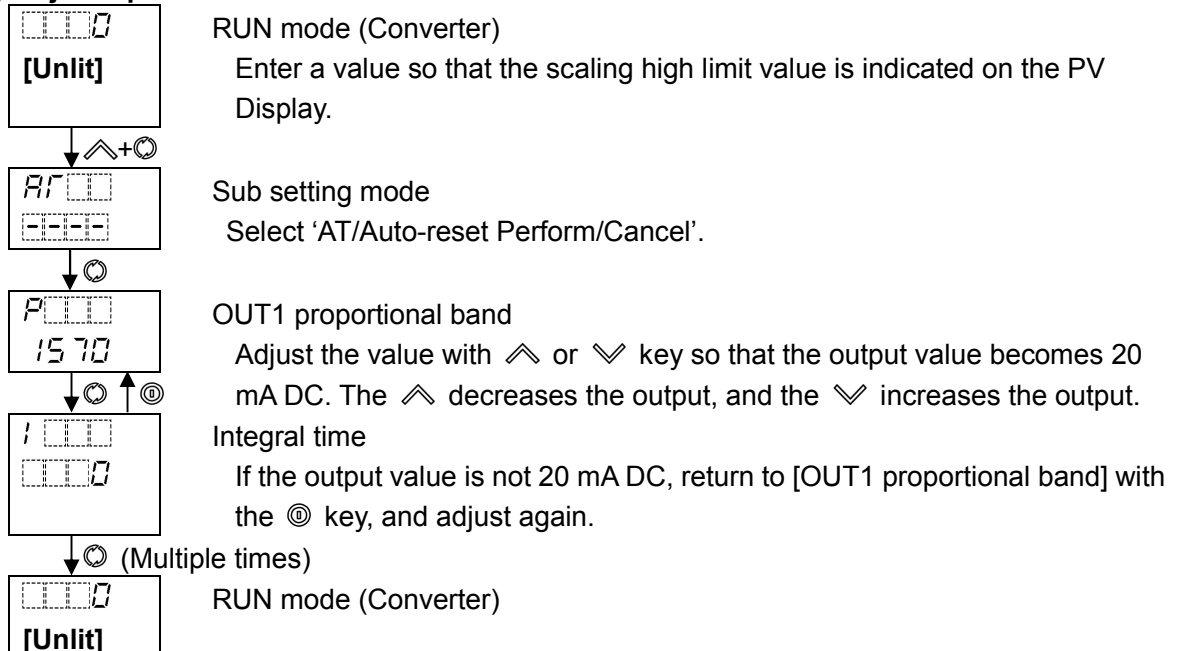

(3) Repeat (1) and (2) until the correct value is output.

9.5.3 Converter Setting Example

When the input is any other value except 4 to 20 mA DC

Input and output conditions:

Input: 6 to 14 mA DC (Indication: 30.0 to 130.0),

Output: 4 to 20 mA DC

Setting method

(1) Calculating Scaling high and low limit values of 4 to 20 mA DC

Indication value per mA DC: $(130.0 - 30.0) \div (14 - 6) = 100 \div 8 = 12.5$

Scaling high limit value: $130.0 + (20 - 14) \times 12.5 = 205.0$

Scaling low limit value $30.0 - (6 - 4) \times 12.5 = 5.0$

(2) Calculating OUT1 Proportional band of 6 to 14 mA DC (Slope setting)

OUT1 Proportional band (P) = $\{(14 - 6) \div (20 - 4)\} \times 100 = 0.5 \times 100 = 50 (\%)$

(3) Calculating SV (desired value) so that 4 mA DC output can be obtained from 6 mA DC input (Parallel shift setting)

SV = $\{(6 - 4) \times 12.5\} + 5.0$ (Scaling low limit) = 30.0

Input, Output and Indication

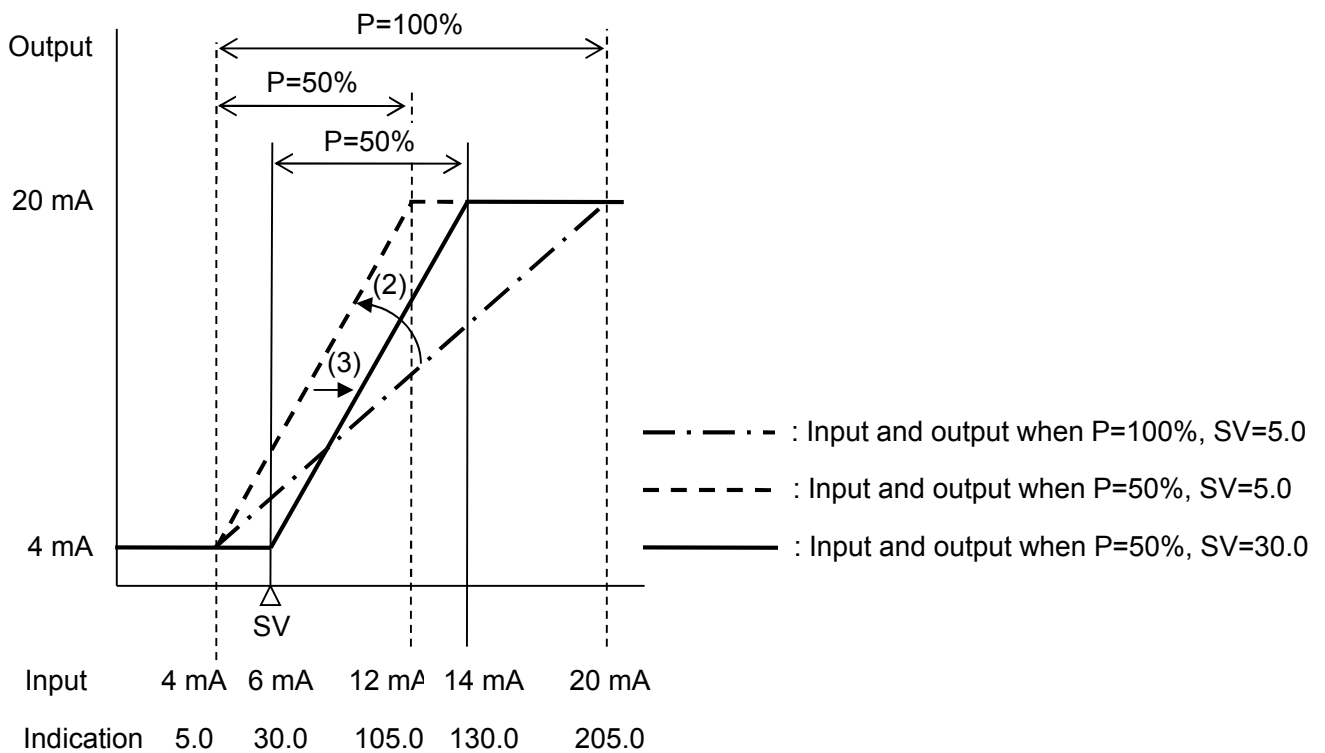

(Fig. 9.5.3-1)

9.6 Clearing Data

If data is cleared, data will revert to factory default values.

To clear data, press and hold \wedge , \vee , \odot , \odot (in that order) together for approx. 3 seconds on the PV/SV Display.

The unit enters [Data clear Yes/No] mode.

Select 'Yes', and press the \odot key. Data will be cleared.

While data is clearing, *i n i t* is indicated on the PV Display.

Clearing Data

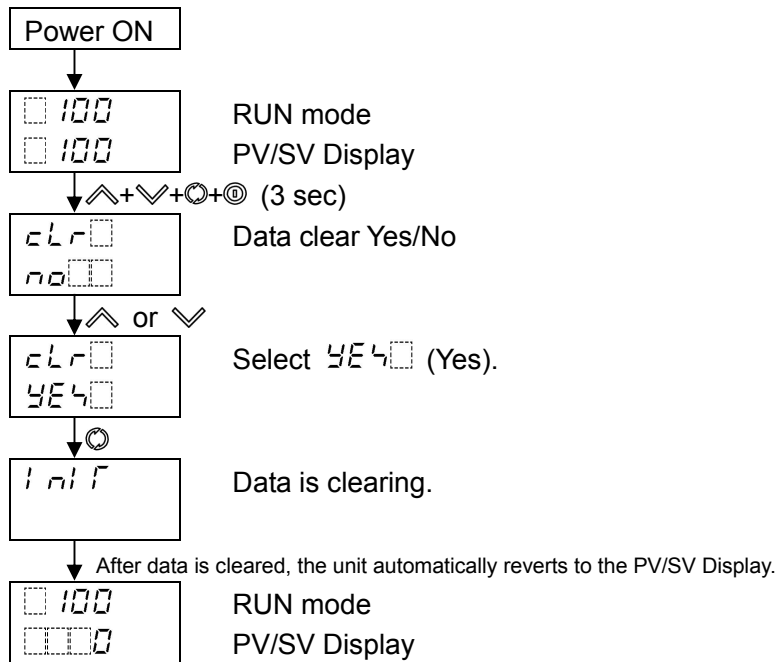

10. Action Explanation

10.1 OUT1 Action (BCS2)

Action	Reverse (Heating) Action	Direct (Cooling) Action
Control action		
Relay contact output		
Non-contact voltage output		
Direct current output		
Indicator (O1) Green		

: Turns ON (lit) or OFF (unlit).

BCR2, BCD2: OUT1 terminal numbers: 15, 16

10.2 OUT1 ON/OFF Control Action (BCS2)

Action	Reverse (Heating) Action	Direct (Cooling) Action
Control action		
Relay contact output		
Non-contact voltage output		
Direct current output		
Indicator (O1) Green		

: Turns ON (lit) or OFF (unlit).

BCR2, BCD2: OUT1 terminal numbers: 15, 16

10.3 Heater Burnout Alarm Action

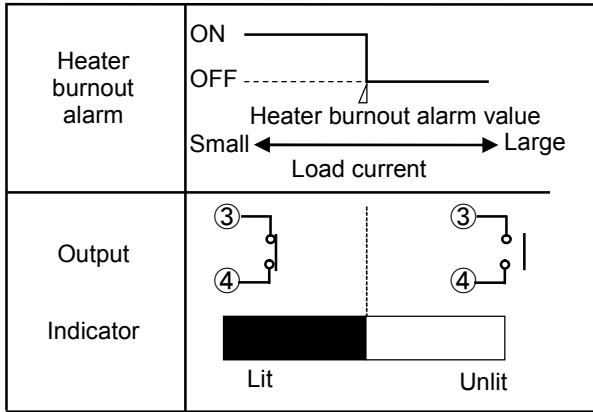

- BCS2: Event output 1 terminal numbers: 3, 4
Event output 2 terminal numbers: 5, 6
- BCR2, BCD2: Event output 1 terminal numbers: 17, 18
Event output 2 terminal numbers: 19, 20
If EV2+D□ option is ordered: Event output 2 terminal numbers: 6, 7

10.4 Alarm Action (BCS2)

	High limit alarm	Low limit alarm
Alarm action	<p>Diagram showing alarm action for a high limit alarm. The process value (PV) is compared to the setpoint (SV). When PV reaches the +EV1 value, the alarm turns ON. When PV returns to the SV, the alarm turns OFF. When PV reaches the -EV1 value, the alarm turns ON again. The hysteresis is indicated by the width of the ON pulse.</p>	<p>Diagram showing alarm action for a low limit alarm. The process value (PV) is compared to the setpoint (SV). When PV reaches the -EV1 value, the alarm turns ON. When PV returns to the SV, the alarm turns OFF. When PV reaches the +EV1 value, the alarm turns ON again. The hysteresis is indicated by the width of the ON pulse.</p>
Alarm output	<p>Diagram showing alarm output for a high limit alarm. The + side (top bar) is ON (black) when PV is above the +EV1 value. The - side (bottom bar) is ON (black) when PV is below the -EV1 value. The hysteresis is shown as a hatched area between the ON and OFF states.</p>	<p>Diagram showing alarm output for a low limit alarm. The + side (top bar) is ON (black) when PV is below the -EV1 value. The - side (bottom bar) is ON (black) when PV is above the +EV1 value. The hysteresis is shown as a hatched area between the ON and OFF states.</p>
	High/Low limits alarm	High/Low limits independent alarm
Alarm action	<p>Diagram showing alarm action for a high/low limits alarm. The process value (PV) is compared to the setpoint (SV). When PV reaches the EV1 value, the alarm turns ON. When PV returns to the SV, the alarm turns OFF. When PV reaches the EV1 value again, the alarm turns ON again. The hysteresis is indicated by the width of the ON pulse.</p>	<p>Diagram showing alarm action for a high/low limits independent alarm. The process value (PV) is compared to the setpoint (SV). When PV reaches the EV1 low limit value, the alarm turns ON. When PV returns to the SV, the alarm turns OFF. When PV reaches the EV1 high limit value, the alarm turns ON again. The hysteresis is indicated by the width of the ON pulse.</p>
Alarm output	<p>Diagram showing alarm output for a high/low limits alarm. The + side (top bar) is ON (black) when PV is above the EV1 value. The - side (bottom bar) is ON (black) when PV is below the EV1 value. The hysteresis is shown as a hatched area between the ON and OFF states.</p>	<p>Diagram showing alarm output for a high/low limits independent alarm. The + side (top bar) is ON (black) when PV is below the EV1 low limit value. The - side (bottom bar) is ON (black) when PV is above the EV1 high limit value. The hysteresis is shown as a hatched area between the ON and OFF states.</p>
	High/Low limit range alarm	High/Low limit range independent alarm
Alarm action	<p>Diagram showing alarm action for a high/low limit range alarm. The process value (PV) is compared to the setpoint (SV). When PV reaches the EV1 value, the alarm turns ON. When PV returns to the SV, the alarm turns OFF. When PV reaches the EV1 value again, the alarm turns ON again. The hysteresis is indicated by the width of the ON pulse.</p>	<p>Diagram showing alarm action for a high/low limit range independent alarm. The process value (PV) is compared to the setpoint (SV). When PV reaches the EV1 low limit value, the alarm turns ON. When PV returns to the SV, the alarm turns OFF. When PV reaches the EV1 high limit value, the alarm turns ON again. The hysteresis is indicated by the width of the ON pulse.</p>
Alarm output	<p>Diagram showing alarm output for a high/low limit range alarm. The + side (top bar) is ON (black) when PV is above the EV1 value. The - side (bottom bar) is ON (black) when PV is below the EV1 value. The hysteresis is shown as a hatched area between the ON and OFF states.</p>	<p>Diagram showing alarm output for a high/low limit range independent alarm. The + side (top bar) is ON (black) when PV is below the EV1 low limit value. The - side (bottom bar) is ON (black) when PV is above the EV1 high limit value. The hysteresis is shown as a hatched area between the ON and OFF states.</p>
	Process high alarm	Process low alarm
Alarm action	<p>Diagram showing alarm action for a process high alarm. The process value (PV) is compared to the setpoint (SV). When PV reaches the EV1 value, the alarm turns ON. When PV returns to the SV, the alarm turns OFF. The hysteresis is indicated by the width of the ON pulse.</p>	<p>Diagram showing alarm action for a process low alarm. The process value (PV) is compared to the setpoint (SV). When PV reaches the EV1 value, the alarm turns ON. When PV returns to the SV, the alarm turns OFF. The hysteresis is indicated by the width of the ON pulse.</p>
Alarm output	<p>Diagram showing alarm output for a process high alarm. The + side (top bar) is ON (black) when PV is above the EV1 value. The - side (bottom bar) is ON (black) when PV is below the EV1 value. The hysteresis is shown as a hatched area between the ON and OFF states.</p>	<p>Diagram showing alarm output for a process low alarm. The + side (top bar) is ON (black) when PV is below the EV1 value. The - side (bottom bar) is ON (black) when PV is above the EV1 value. The hysteresis is shown as a hatched area between the ON and OFF states.</p>

	High limit with standby alarm	Low limit with standby alarm
Alarm action		
Alarm output		
	High/Low limits with standby alarm	High/Low limits with standby independent
Alarm action		
Alarm output		

- : Event output EV1 terminals 3, 4: ON
- : Event output EV1 terminals 3, 4: ON or OFF
- : Event output EV1 terminals 3, 4: OFF
- : Alarm output is in standby.

- EV1 value, EV1 high limit value, and EV1 hysteresis represent EV1 alarm value, EV1 high limit alarm value, and EV1 alarm hysteresis respectively.
For EV2, read “EV2” for “EV1”.
- EV1 indicator lights when Event output 1 terminals 3 and 4 are ON, and turns off when their output terminals 3 and 4 are OFF.
EV2 indicator lights when Event output 2 terminals 5 and 6 are ON, and turns off when their output terminals 5 and 6 are OFF.
- BCR2, BCD2: Event output 1 terminal numbers: 17, 18
Event output 2 terminal numbers: 19, 20
If EV2+D□ option is added: Event output 2 terminal numbers: 6, 7

10.5 OUT2 (Heating/Cooling Control) Action (BCS2)

Control action				
Relay contact output (OUT1)				
Non-contact voltage output (OUT1)	+ ⑦ 12 V DC - ⑧	+ ⑦ 12/0 V DC - ⑧	+ ⑦ 0 V DC - ⑧	
Direct current output (OUT1)	+ ⑦ 20 mA DC - ⑧	+ ⑦ 20 to 4 mA DC - ⑧	+ ⑦ 4 mA DC - ⑧	
Non-contact voltage output (OUT2)				
Non-contact voltage output (OUT2)		+ ⑤ 0 V DC - ⑥	+ ⑤ 0/12 V DC - ⑥	+ ⑤ 12 V DC - ⑥
Direct current output (OUT2)		+ ⑤ 4 mA DC - ⑥	+ ⑤ 4 to 20 mA DC - ⑥	+ ⑤ 20 mA DC - ⑥
Indicator (O1)				
Indicator (O2)				

: Turns ON (lit) or OFF (unlit).

— : Represents Heating control action.

- - - - : Represents Cooling control action.

- BCR2, BCD2: OUT1 terminal numbers: 15, 16
OUT2 terminal numbers: 19, 20

10.6 OUT2 (Heating/Cooling Control) Action (When Setting Dead Band) (BCS2)

Control			
Relay contact output (OUT1)	<p>Cycle action is performed according to deviation</p>		
Non-contact voltage output (OUT1)	<p>Cycle action is performed according to deviation.</p>		
Direct current output (OUT1)	<p>Changes continuously according to deviation.</p>		
Relay contact output (OUT2)	<p>Cycle action is performed according to deviation.</p>		
Non-contact voltage output (OUT2)	<p>Cycle action is performed according to deviation.</p>		
Direct current output (OUT2)	<p>Changes continuously according to deviation.</p>		
Indicator (O1)	<p>Lit Unlit</p>		
Indicator (O2)	<p>Unlit Lit</p>		

- : Turns ON (lit) or OFF (unlit).
- : Represents Heating control action.
- - - - : Represents Cooling control action.

- BCR2, BCD2: OUT1 terminal numbers: 15, 16
OUT2 terminal numbers: 19, 20

10.7 OUT2 (Heating/Cooling Control) Action (When Setting Overlap Band) (BCS2)

Control action	
Relay contact output (OUT1)	<p>Cycle action is performed according to deviation.</p>
Non-contact voltage output (OUT1)	<p>Cycle action is performed according to deviation.</p>
Direct current output (OUT1)	<p>Changes continuously according to deviation.</p>
Relay contact output (OUT2)	<p>Cycle action is performed according to deviation.</p>
Non-contact voltage output (OUT2)	<p>Cycle action is performed according to deviation.</p>
Direct current output (OUT2)	<p>Changes continuously according to deviation.</p>
Indicator (O1)	<p>Lit Unlit</p>
Indicator (O2)	<p>Unlit Lit</p>

: Turns ON (lit) or OFF (unlit).

— : Represents Heating control action.

- - - - : Represents Cooling control action.

- BCR2, BCD2: OUT1 terminal numbers: 15, 16
OUT2 terminal numbers: 19, 20

11. Specifications

11.1 Standard Specifications

Rating

Rated scale		Input	Scale Range	Resolution	
		K	-200 to 1370°C	-328 to 2498°F	1°C (°F)
			-200.0 to 400.0°C	-328.0 to 752.0°F	0.1°C (°F)
		J	-200 to 1000°C	-328 to 1832°F	1°C (°F)
		R	0 to 1760°C	32 to 3200°F	1°C (°F)
		S	0 to 1760°C	32 to 3200°F	1°C (°F)
		B	0 to 1820°C	32 to 3308°F	1°C (°F)
		E	-200 to 800°C	-328 to 1472°F	1°C (°F)
		T	-200.0 to 400.0°C	-328.0 to 752.0°F	0.1°C (°F)
		N	-200 to 1300°C	-328 to 2372°F	1°C (°F)
		PL-II	0 to 1390°C	32 to 2534°F	1°C (°F)
		C(W/Re5-26)	0 to 2315°C	32 to 4199°F	1°C (°F)
		Pt100	-200.0 to 850.0°C	-328.0 to 1562.0°F	0.1°C (°F)
			-200 to 850°C	-328 to 1562°F	1°C (°F)
		JPt100	-200.0 to 500.0°C	-328.0 to 932.0°F	0.1°C (°F)
			-200 to 500°C	-328 to 932°F	1°C (°F)
		4 to 20 mA	-2000 to 10000 (*)		1
		0 to 20 mA	-2000 to 10000 (*)		1
		0 to 1 V	-2000 to 10000 (*)		1
		0 to 5 V	-2000 to 10000 (*)		1
		1 to 5 V	-2000 to 10000 (*)		1
0 to 10 V	-2000 to 10000 (*)		1		
(*) Scaling and decimal point place selection are possible.					
Input	Thermocouple	K, J, R, S, B, E, T, N, PL-II, C(W/Re5-26) External resistance: 100 Ω max. However, for B input, External resistance: 40 Ω max.			
	RTD	Pt100, JPt100 3-wire type Allowable input lead wire resistance: 10 Ω max. per wire			
	Direct current	0 to 20 mA DC, 4 to 20 mA DC Input impedance: 50 Ω Allowable input current: 50 mA max.			
	DC voltage	0 to 1 V DC Input impedance: 1 MΩ min. Allowable input voltage: 5 V DC max. Allowable signal source resistance: 2 kΩ max.			
0 to 5 V DC, 1 to 5 V DC, 0 to 10 V DC Input impedance: 100 kΩ min. Allowable input voltage: 15 V DC max. Allowable signal source resistance: 100 Ω max.					
Power supply voltage	BC□2□00-□□	100 to 240 V AC 50/60 Hz			
	BC□2□10-□□	24 V AC/DC 50/60 Hz			
Allowable voltage fluctuation	BC□2□00-□□	85 to 264 V AC			
	BC□2□10-□□	20 to 28 V AC/DC			

General Structure

External dimensions	BCS2	48 x 48 x 68 mm (W x H x D) (Depth of control panel interior: 60 mm)		
	BCR2	48 x 96 x 68 mm (W x H x D) (Depth of control panel interior: 60 mm)		
	BCD2	96 x 96 x 68 mm (W x H x D) (Depth of control panel interior: 60 mm)		
Mounting		Flush		
Case		Flame-resistant resin, Black		
Front panel		Membrane sheet		
Drip-proof/Dust-proof		Front panel: IP66, Rear case: IP20, Terminal section: IP00		
Compliant standards	EN	EN61010-1 (Pollution degree 2, Overvoltage category II)		
	EC (EMC directive)	EMI: EN61326 Electric-field strength of radiated disturbance: EN55001 Group 1 Class A Terminal noise voltage: EN55011 Group 1 Class A EMS: EN61326		
Indication structure	PV Display	Indicates PV. 7-segment Red LED display		
		BCS2	Character size: 12.4 x 5.8 mm (H x W)	
		BCR2	Character size: 14 x 5.8 mm (H x W)	
		BCD2	Character size: 24 x 11 mm (H x W)	
	SV Display	Indicates SV. 7-segment Green LED display		
		BCS2	Character size: 8.8 x 3.9 mm (H x W)	
		BCR2	Character size: 14 x 5.8 mm (H x W)	
		BCD2	Character size: 14 x 7 mm (H x W)	
	MEMO/STEP Display (BCR2, BCD2)	Indicates Set value memory number (Fixed value control) or Step number (Program control). 7-segment Green LED display		
		BCR2	Character size: 14 x 5.8 mm (H x W)	
		BCD2	Character size: 14 x 7 mm (H x W)	
	Action indicators	O1 (Green)	Lit when control output OUT1 is ON. For direct current output type, flashes corresponding to the MV in 125 ms cycles.	
		O2 (Yellow)	Lit when control output OUT2 (EV2, DS, DA, EV2+D□ options) is ON. For direct current output type (DA, EV2+DA options), flashes corresponding to the MV in 125 ms cycles.	
		EV1 (Red)	Lit when Event output 1 is ON.	
		EV2 (Red)	Lit when Event output 2 (EV2, EV2+D□ options) is ON. Unlit if □□ 19 (Heating/Cooling control relay contact output) is selected in [Event output EV2 allocation].	
		AT (Yellow)	Flashes while AT, 'AT on startup' or Auto-reset is performing.	
		R/L (Yellow)	Lit during Remote action from Remote/Local switching (EIT option).	
		T/R (Yellow)	Lit during Serial communication (C5W, C5 options) TX (transmitting) output.	
		MEMO (Yellow)	Lit when Set value memory number (Fixed value control) is indicated. (BCR2, BCD2)	
		STEP (Green)	Lit when a step number (Program control) is indicated. (BCR2, BCD2)	

Terminal arrangement	Refer to 'Terminal arrangement'. (p.19)
Console connector	By connecting to the tool cable (CMD-001, sold separately), the following operations can be conducted from an external computer using the Console software SWC-BCx01M. <ul style="list-style-type: none"> • Reading and setting of SV, PID and various set values • Reading of PV and action status • Function change

Setting Structure

Function key	UP key	Increases the numeric value. By pressing this key for 1 second during Program control, the performing step is interrupted, proceeding to the beginning of the next step. (Advance function)	
	DOWN key	Decreases the numeric value.	
	MODE key	Selects a setting mode, or registers the set data. By pressing this key for 3 seconds during RUN mode, the unit enters Monitor mode.	
	OUT/OFF key	The following function can be selected in [OUT/OFF key function].	
		Selection Item	Action
		Control output OFF function	Turns the control output ON or OFF.
		Auto/Manual control	Switches the Auto/Manual control.
Program control	Starts/Stops the Program control.		

Indication Performance

Base accuracy	At ambient temperature 23°C (for a single unit mounting)	
Thermocouple	Within $\pm 0.2\%$ of each input span ± 1 digit However R, S inputs, 0 to 200°C (32 to 392°F): Within $\pm 6^\circ\text{C}$ (12°F) B input, 0 to 300°C (32 to 572°F): Accuracy is not guaranteed. K, J, E, T, N inputs, Less than 0°C (32°F): Within $\pm 0.4\%$ of input span ± 1 digit	
RTD	Within $\pm 0.1\%$ of each input span ± 1 digit	
Direct current, DC voltage	Within $\pm 0.2\%$ of each input span ± 1 digit	
Effect of ambient temperature	Within 50 ppm/°C of each input span	
Input sampling period	125 ms	
Time accuracy	Within $\pm 1.0\%$ of setting time	

Control Performance

Control action	<ul style="list-style-type: none"> • PID control (with AT function) • PI control: When derivative time is set to 0 • PD control (with Auto-reset, Manual reset function): When integral time is set to 0 • P control (with Auto-reset, Manual reset function): When derivative time and integral time are set to 0. • ON/OFF control: When proportional band is set to 0 (or 0.0) 	
OUT1 proportional band	Thermocouple, RTD inputs without decimal point: 0 to input span Thermocouple, RTD inputs with decimal point: 0.0 to input span Direct current, voltage inputs: 0.0 to 1000.0%	
Integral time	0 to 3600 sec	
Derivative time	0 to 1800 sec	
OUT1 proportional cycle	0.5, or 1 to 120 sec	
ARW	0 to 100%	

	Manual reset	\pm Proportional band value
	OUT1 ON/OFF hysteresis	Thermocouple, RTD inputs: 0.1 to 1000.0°C (°F) Direct current, voltage inputs: 1 to 10000 (The placement of the decimal point follows the selection.)
	OUT1 high limit, OUT1 low limit	0 to 100% (Direct current output type: -5 to 105%)
Control output	Relay contact 1a	Control capacity: 3 A 250 V AC (resistive load) 1 A 250 V AC (inductive load $\cos\phi=0.4$) Electrical life: 100,000 cycles Minimum applicable load: 10 mA 5 V DC
	Non-contact voltage (For SSR drive)	12 V DC \pm 15% Max 40 mA (short circuit protected)
	Direct current	4 to 20 mA DC Resolution: 12000 Load resistance: Max. 550 Ω

Standard Function

EV1 output	The output is turned ON or OFF depending on the conditions selected in [Event output EV1 allocation]. Relay contact 1a Control capacity: 3 A 250 V AC (resistive load) 1 A 250 V AC (inductive load $\cos\phi=0.4$) Electrical life: 100,000 cycles Minimum applicable load: 10 mA 5 V DC
Alarm action	When an alarm type and Energized action are selected in [Event output EV1 allocation] or [Event output EV2 allocation]: The alarm action point is set by \pm deviation from the SV (excluding Process alarm) and if PV goes outside the range, alarm output is turned ON or OFF (High/Low limit range alarm). When De-energized action is selected, alarm is activated conversely.
Type	High limit alarm, Low limit alarm, High/Low limits alarm, High/Low limits independent alarm, High/Low limit range alarm, High/Low limit range independent alarm, Process high alarm, Process low alarm, High limit with standby alarm, Low limit with standby alarm, High/Low limits with standby alarm, High/Low limits with standby independent alarm Energized/De-energized action are applied to the above alarms, totaling 24 alarm types. No alarm action can also be selected.
Action	ON/OFF action
Hysteresis	Thermocouple, RTD inputs: 0.1 to 1000.0°C (°F) Direct current, voltage inputs: 1 to 10000 (The placement of the decimal point follows the selection.)
Output	EV1 output or EV2 output for which Alarm output (001 to 012) is selected in [Event output EV1/EV2 allocation].
Alarm value 0 Enabled/ Disabled	If 'Enabled' is selected in [Alarm value 0 Enabled/Disabled], the following alarm type activates even if alarm value is set to 0 (zero): High limit alarm, Low limit alarm, High/Low limits alarm, High/Low limits independent alarm, High/Low limit range alarm, High/Low limit range independent alarm, High limit with standby alarm, Low limit with standby alarm, High/Low limits with standby alarm, High/Low limits with standby independent alarm.
Loop break alarm	Detects heater burnout, sensor burnout and actuator trouble. Event output EV1 or Event output EV2 for which Loop break alarm (014) is selected in [Event output EV1/EV2 allocation].

Simplified converter function	If 'Converter' is selected in [Controller/Converter], this instrument can be used as a converter. The following items are automatically set.	
	Setting Item	Values or Selection
	SV1	Scaling low limit value
	SV2 (BCS2: EIW, EIT, EI options, BCR2/BCD2: C5W, EIW, EIT, EI options)	Scaling low limit value
	SV3 (BCS2: EIW, EI options, BCR2/BCD2: C5W, EIW, EIT, EI options)	Scaling low limit value
	SV4 (BCS2: EIW, EI options, BCR2/BCD2: C5W, EIW, EIT, EI options)	Scaling low limit value
	AT/Auto-reset Perform/Cancel	AT/AT on startup/Auto-reset Cancel
	OUT1 proportional band	Scaling span
	Integral time	0
	Derivative time	0
	Reset	0 (Initialized) (Reset value calculated by Auto-reset function)
	OUT1 high limit	100
	OUT1 low limit	0
	OUT1 rate-of-change	0
	OUT2 proportional band	Scaling span
	Direct/Reverse action	Direct action
	EV1/EV2 alarm value 0 Enabled/Disabled	Disabled
	EV1/EV2 alarm value	0 or Input range low limit value (Scaling low limit value)
	EV1/EV2 high limit alarm value	0 or Input range low limit value (Scaling low limit value)
	EV1/EV2 alarm hysteresis	1.0 (DC voltage, current inputs: The placement of the decimal point follows the selection.)
	EV1/EV2 alarm delay time	0
	EV1/EV2 alarm Energized/ De-energized	Energized
	Loop break alarm time	0
	Loop break alarm span	0
	Event input DI1 allocation (BCS2: EIW, EIT, EI options, BCR2/BCD2: C5W, EIW, EIT, EI options)	No event
	Event input DI2 allocation (BCS2: EIW, EI options, BCR2/BCD2: C5W, EIW, EIT, EI options)	No event
	Event output EV1 allocation	No event
	Event output EV2 allocation (EV2, EV2+D□ options)	No event
	Remote/Local (EIT option)	Local

Transmission output type (EIT option)	PV transmission
Transmission output high limit (EIT option)	Input range high limit
Transmission output low limit (EIT option)	Input range low limit
SV rise rate	0
SV fall rate	0
OUT/OFF key function	Control output OFF
4 to 20 mA DC Load resistance: Max 550 Ω	

Insulation, Dielectric Strength

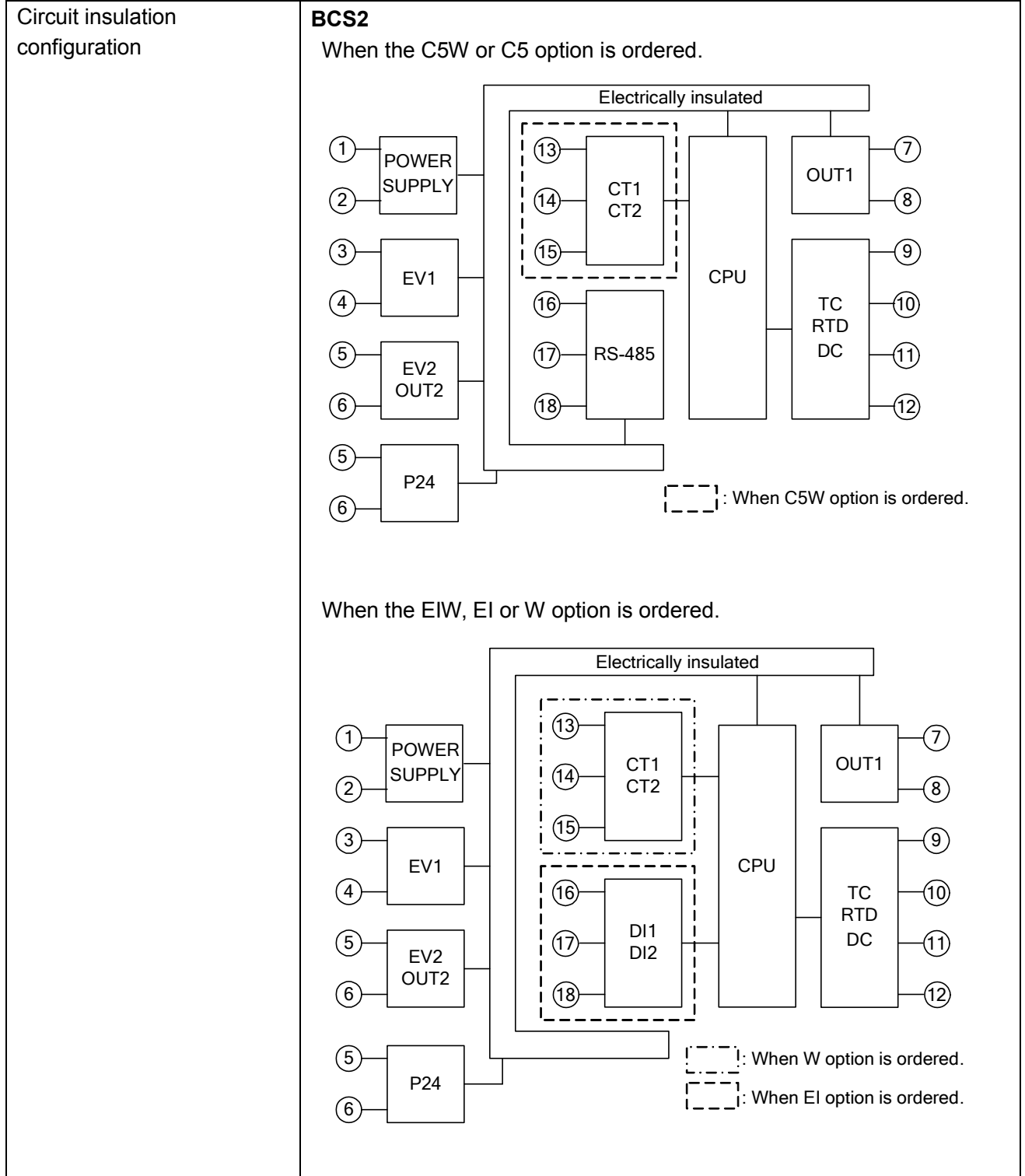

Circuit insulation configuration

When the EIT option is ordered.

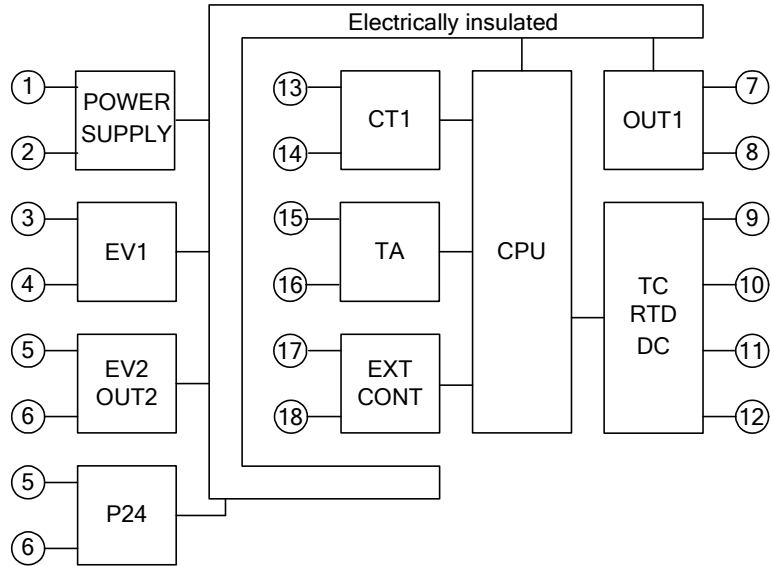

When OUT1 is a non-contact voltage output or direct current output type, and when OUT2 is a non-contact voltage output or direct current output type, OUT1 is not electrically insulated from OUT2.
Insulation resistance: 10 MΩ min., at 500 V DC

BCR2, BCD2

When the C5W or C5 option is ordered.

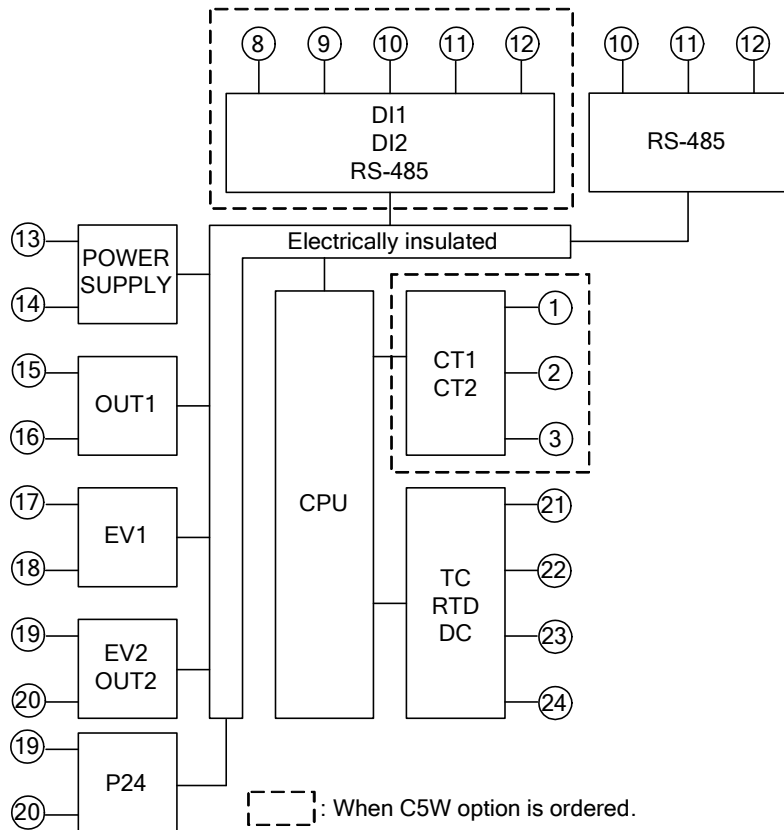

Circuit insulation configuration

When the EIW or W option is ordered.

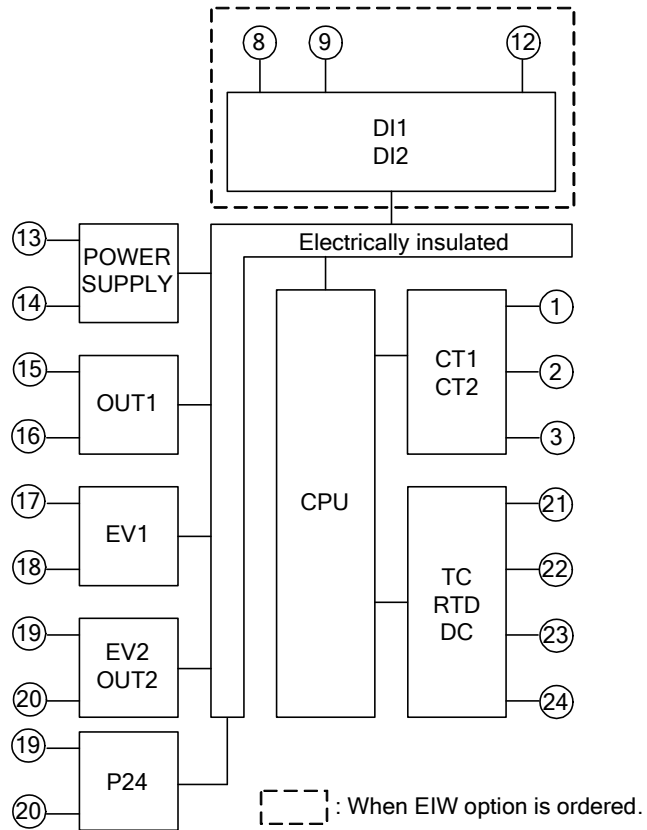

When the EIT or EI option is ordered.

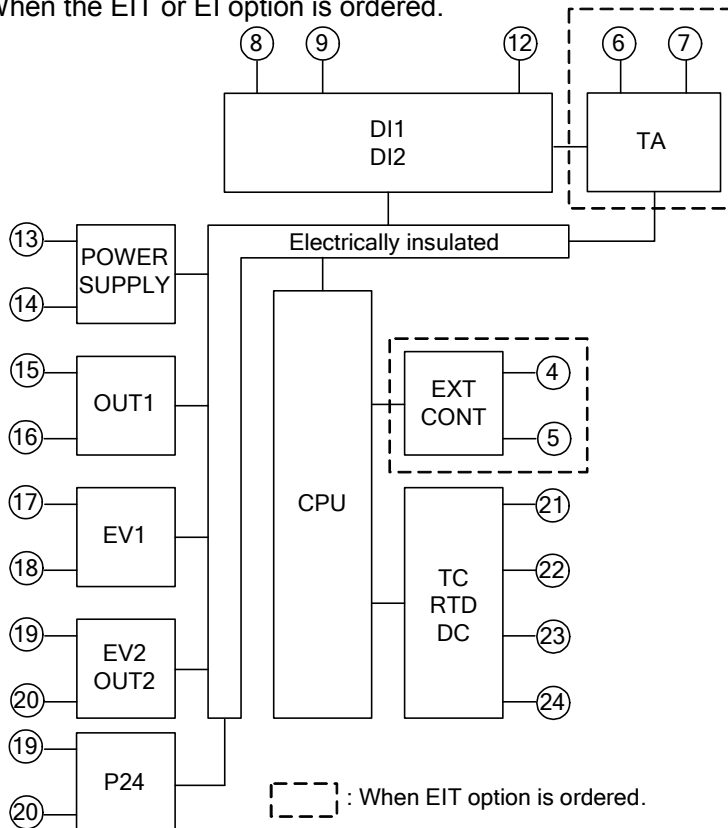

When EV2+D□ option and EIT option are added simultaneously, EV2 terminal numbers become 6 and 7, and OUT2 terminal numbers become 19 and 20.

When OUT1 is a non-contact voltage output or direct current output type, and when OUT2 is a non-contact voltage output or direct current output type, OUT1 is not electrically insulated from OUT2.

Insulation resistance: 10 MΩ min., at 500 V DC

Dielectric strength

Between input terminal and power terminal: 1.5 kV AC for 1 minute
Between output terminal and power terminal: 1.5 kV AC for 1 minute
Between output terminal (P24) and power terminal: 500 V AC for 1 minute

Power consumption	100 to 240 V AC	Approx. 8 VA max. (When the maximum number of options are added: Approx. 11 VA max.)
	24 V AC	Approx. 5 VA max. (When the maximum number of options are added: Approx. 8 VA max.)
	24 V DC	Approx. 5 W max. (When the maximum number of options are added: Approx. 8 W max.)
Rush current	100 to 240 V AC	Max. 14 to 34 A
	24 V AC	Max. 34 A
	24 V DC	Max. 34 A
Ambient temperature	-10 to 55°C (Non-condensing, No icing)	
Ambient humidity	35 to 85 %RH (Non-condensing)	
Weight	BCS2	Approx. 110 g
	BCR2	Approx. 160 g
	BCD2	Approx. 220 g
Accessories included	Mounting frame: 1 piece (BCS2) Screw type mounting bracket: 1 set (BCR2, BCD2) Instruction manual (excerpt): 1 copy	
Accessories sold separately	Terminal cover CT (Current transformer): CTL-6-S-H (For Heater burnout alarm 20 A) CTL-12-S36-10L1U (For Heater burnout alarm 100 A) Tool cable CMD-001	
Environmental specification	RoHS directive compliant	

Attached Functions

Sensor correction coefficient	Sets slope of input value from a sensor.	
Sensor correction	Corrects the input value from a sensor.	
Set value lock	Locks the set values to prevent setting errors.	
Auto/Manual control switching	Switches Auto/Manual control. In Manual control, sets MV with the \wedge or \vee key.	
SV ramp function	When the SV is adjusted, it approaches the new SV by the preset rate-of-change. Set SV rise rate and SV fall rate respectively.	
SV Rise/Fall rate start type	When control output is turned from OFF to ON, or switched from Manual to Automatic control, SV start or PV start can be selected for SV rise rate or SV fall rate action.	
Program control	1 pattern; 9 steps	
Power failure countermeasure	The setting data is backed up in the non-volatile IC memory.	
Self-diagnosis	The CPU is monitored by a watchdog timer, and if an abnormal status occurs, the controller is switched to warm-up status, turning all outputs OFF.	
Automatic cold junction temperature compensation	This detects the temperature at the connecting terminal between the thermocouple and the instrument, and always maintains it at the same status as if the reference junction location temperature was at 0°C (32°F).	
Indication range, Control range	Thermocouple	[Input range low limit value - 50°C (100°F)] to [Input range high limit value + 50°C (100°F)]
	RTD	[Input range low limit value - (Input span x 1%)] to [Input range high limit value + 50°C (100°F)]
	DC voltage, Direct current	[Scaling low limit value - (Scaling span x 1%)] to [Scaling high limit value + (Scaling span x 10%)]

Input error (Overscale, Underscale)	<p>If input errors (overscale, underscale) occur, the following will be performed depending on the selection in [Error indication Enabled/Disabled].</p> <p>If Disabled is selected in [Error indication Enabled/Disabled]: Overscale occurs if PV has exceeded Input range high limit value (Scaling high limit value for DC voltage, current inputs). The PV Display indicates PV. Underscale occurs if PV has dropped below Input range low limit value (Scaling low limit value for DC voltage, current inputs). The PV Display indicates PV. For manual control, the preset MV is output.</p> <p>If Enabled is selected in [Error indication Enabled/Disabled]: Overscale occurs if PV has exceeded Input range high limit value (Scaling high limit value for DC voltage, current inputs). The PV Display indicates the PV and error code $ErOS$ alternately. Underscale occurs if PV has dropped below Input range low limit value (Scaling low limit value for DC voltage, current inputs). The PV Display indicates the PV and error code $ErOE$ alternately. For manual control, the preset MV is output.</p>
-------------------------------------	---

Burnout

If burnout occurs, the following will be performed depending on the selection in [Error indication Enabled/Disabled].

If Disabled is selected in [Error indication Enabled/Disabled]:
If PV has exceeded Indication range and Control range, the PV Display flashes [- - - -].
If PV has dropped below Indication range and Control range, the PV Display flashes [- - - -].
If thermocouple or RTD input is burnt out, or if DC voltage (0 to 1 V DC) input is disconnected, the PV Display flashes [- - - -].

If DC voltage or current input is disconnected:
For 4 to 20 mA DC, 1 to 5 V DC inputs, the PV Display flashes [- - - -].
For 0 to 20 mA DC, 0 to 5 V DC and 0 to 10 V DC inputs, the PV Display indicates the value corresponding with 0 mA DC or 0 V DC input.

OUT1 and OUT2 are turned OFF (OUT1 low limit value for direct current output, OUT2 low limit value for DA, EV2+DA). For manual control, the preset MV is output.

If Alarm, Heater burnout alarm or Loop break alarm is selected in [Event output EV1/EV2 allocation], Event output will be turned ON under the alarm active conditions.

Burnout is enabled even in standby (program control waiting) mode in Program control.

[Output status when input errors occur] can be used only for controllers using direct current and voltage inputs, and direct current output.
Output status differs depending on selection in [Output status when input errors occur].

Output status when input errors occur	Contents, Indication	Output Status			
		OUT1		OUT2	
		Direct (Cooling) action	Reverse (Heating) action	Direct (Cooling) action	Reverse (Heating) action
on	[- - - -] is flashing.	ON (20mA) or OUT1 high limit value (*)	OFF (4mA) or OUT1 low limit value	OFF or OUT2 low limit value	ON or OUT2 high limit value (*)
off		OFF (4mA) or OUT1 low limit value			OFF or OUT2 low limit value
on	[- - - -] is flashing.	OFF (4mA) or OUT1 low limit value	ON (20mA) or OUT1 high limit value (*)	ON or OUT2 high limit value (*)	OFF or OUT2 low limit value
off			OFF (4mA) or OUT1 low limit value	OFF or OUT2 low limit value	

(*) Outputs a value between OFF (4mA) and ON (20mA) or between OUT1 (or OUT2) low limit value and OUT1 (or OUT2) high limit value, depending on deviation.

If Enabled is selected in [Error indication Enabled/Disabled]:

If PV has exceeded Indication range, Control range, the PV Display indicates [- - -] and [Err07] alternately.

If PV has dropped below Indication range, Control range, the PV Display indicates [- - -] and [Err07] alternately.

If thermocouple, RTD or DC voltage (0 to 1 V DC) input is burnt out or disconnected, the PV Display indicates [- - -] and [Err07] alternately.

If DC voltage or current input is disconnected:

For 4 to 20 mA DC, 1 to 5 V DC inputs, the PV Display indicates [- - -] and [Err07] alternately.

For 0 to 20 mA DC, 0 to 5 V DC and 0 to 10 V DC inputs, the PV Display indicates the value corresponding with 0 mA DC or 0 V DC input.

OUT1 and OUT2 are turned OFF (OUT1 low limit value for direct current output type, OUT2 low limit value for DA, EV2+DA).

For Manual control, the preset MV is output.

If Alarm, Heater burnout alarm or Loop break alarm is selected in [Event output EV1/EV2 allocation], Event output will be turned ON under the alarm active conditions.

In Program control, burnout is enabled even in standby (program control waiting) mode.

[Output status when input errors occur] can be used only for controllers using direct current and voltage inputs, and direct current output.

Output status differs depending on selection in [Output status when input errors occur].

Output status when input errors occur	Contents, Indication	Output Status			
		OUT1		OUT2	
		Direct (Cooling) action	Reverse (Heating) action	Direct (Cooling) action	Reverse (Heating) action
on□□	Indicates [- - -] and [Err07] alternately.	ON (20mA) or OUT1 high limit value (*)	OFF (4mA) or OUT1 low limit value	OFF or OUT2 low limit value	ON or OUT2 high limit value (*)
off□□		OFF (4mA) or OUT1 low limit value			OFF or OUT2 low limit value
on□□	Indicates [- - -] and [Err07] alternately.	OFF (4mA) or OUT1 low limit value	ON (20mA) or OUT1 high limit value (*)	ON or OUT2 high limit value (*)	OFF or OUT2 low limit value
off□□			OFF (4mA) or OUT1 low limit value	OFF or OUT2 low limit value	

(*) Outputs a value between OFF (4mA) and ON (20mA) or between OUT1 (or OUT2) low limit value and OUT1 (or OUT2) high limit value, depending on deviation.

Warm-up indication	After the power supply to the instrument is turned on, the PV Display indicates the input type, and SV Display indicates input range high limit value (for thermocouple, RTD inputs) or scaling high limit value (for direct current and voltage inputs) for approximately 3 seconds.
Console communication	By connecting to the tool cable (CMD-001, sold separately) to the console connector, the following operations can be conducted from an external computer, using the Console software SWC-BCx01M. Console communication and Serial communication (C5W option) cannot be used together. (1) Reading and setting of SV, PID and various set values (2) Reading of PV and action status (3) Function change Communication line: TTL level

11.2 Optional Specifications



<p>Event input BCS2: EIW, EIT, EI options BCR2/BCD2: C5W, EIW, EIT, EI options</p>	<p>2 points of Event input (BCS2: 1 point for EIT option) can be applied. Any Event selected in [Event input DI1/DI2 allocation] will be performed depending on the DI1/DI2 input ON (Closed) or OFF (Open) status. Circuit current when Closed: Approx. 16 mA</p>
<p>Event output (EV2, EV2+D□ options)</p>	<p>Output will be turned ON or OFF depending on the Event conditions selected in [Event output EV2 allocation]. Relay contact, 1a Control capacity: 3 A 250 V AC (resistive load) 1 A 250 V AC (inductive load, $\cos\phi=0.4$) Electrical life: 100,000 cycles Minimum applicable load: 10 mA 5 V DC</p>
<p>Heater burnout alarm (C5W, EIW, W options)</p>	<p>Monitors heater current with CT (current transformer), and detects burnout. EV1/EV2 output, for which Heater burnout alarm is selected in [Event output EV1/EV2 allocation], will be turned ON or OFF. This alarm is also activated when the input is burnt out. Rated current: 20 A, 100 A (Must be specified when ordering.) Single-phase: Detects burnout with CT1 input. 3-phase: Detects burnout with CT1 and CT2 inputs. Setting accuracy: Within $\pm 5\%$ of the rated value</p>
<p>Heating/Cooling control (DS, DA, EV2, EV2+D□ options)</p>	<p>Performs Heating/Cooling control. (Heating side specifications are the same as those of OUT1.) OUT2 proportional band: Thermocouple, RTD inputs without decimal point: 0 to Input span Thermocouple, RTD inputs with decimal point: 0.0 to Input span DC voltage, current inputs: 0.0 to 1000.0% OUT2 integral time: Same as OUT1 integral time OUT2 derivative time: Same as OUT1 derivative time OUT2 proportional cycle: 0.5, or 1 or 120 seconds Overlap/Dead band setting range: Thermocouple, RTD inputs: -200.0 to 200.0°C (°F) DC voltage, current inputs: -2000 to 2000 (The placement of the decimal point follows the selection.) OUT2 ON/OFF hysteresis: Thermocouple, RTD inputs: 0.1 to 1000.0°C (°F) DC voltage, current inputs: 1 to 10000 (The placement of the decimal point follows the selection.) OUT2 high limit: 0 to 100% (Direct current output: -5 to 105%) OUT2 low limit: 0 to 100% (Direct current output: -5 to 105%) OUT2 cooling method: One cooling method can be selected from Air cooling (linear characteristics), Oil cooling (1.5th power of the linear characteristics) and Water cooling (2nd power of the linear characteristics) by keypad operation. Cooling output (OUT2): Relay contact 1a (EV2, EV2+DR) Control capacity: 3 A 250 V AC (resistive load) 1 A 250 V AC (inductive load, $\cos\phi=0.4$) Electrical life: 100,000 cycles Non-contact voltage (for SSR drive) (DS, EV2+DS): 12 V DC $\pm 15\%$, Max. 40 mA (short circuit protected) Direct current (DA, EV2+DA): 4 to 20 mA DC Resolution: 12000 Load resistance: Max. 550 Ω</p>

Serial communication (C5W, C5 options)	<p>The following operations can be carried out from an external computer. Serial communication and Console communication cannot be used together.</p> <p>(1) Reading and setting of the SV, PID values and various set values (2) Reading of the PV and action status (3) Function change</p> <p>Cable length: Max 1.2 km, Cable resistance: Within 50 Ω (Terminators are not necessary, but if used, use 120 Ω or more on both sides.)</p> <p>Communication line: EIA RS-485 Communication method: Half-duplex communication Synchronization method: Start-stop synchronization Communication speed: 9600, 19200, 38400 bps (Selectable by keypad) Data bit/Parity: Data bit: 7 bits, 8 bits, (Selectable by keypad) Parity: Even/Odd/No parity (Selectable by keypad) Stop bit: 1 bit, 2 bits (Selectable by keypad) Communication protocol: Shinko protocol/Modbus ASCII/Modbus RTU (Selectable by keypad)</p> <p>Data format:</p> <table border="1" data-bbox="512 831 1481 1151"> <thead> <tr> <th>Communication protocol</th> <th>Shinko protocol</th> <th>Modbus ASCII</th> <th>Modbus RTU</th> </tr> </thead> <tbody> <tr> <td>Start bit</td> <td>1</td> <td>1</td> <td>1</td> </tr> <tr> <td>Data bit</td> <td>7</td> <td>7 (8) Selectable</td> <td>8</td> </tr> <tr> <td>Parity</td> <td>Even</td> <td>Even (No parity, Odd) Selectable</td> <td>No parity (Even, Odd) Selectable</td> </tr> <tr> <td>Stop bit</td> <td>1</td> <td>1 (2) Selectable</td> <td>1 (2) Selectable</td> </tr> </tbody> </table> <p>Number of connectable units: Maximum 31 units to 1 host computer Communication error detection: Parity, checksum (Shinko protocol), LRC (Modbus ASCII), CRC-16 (Modbus RTU)</p> <p>Digital external setting: Receives digital SV from Shinko programmable controllers (PC-900, PCD-33A with SVTC option).</p>	Communication protocol	Shinko protocol	Modbus ASCII	Modbus RTU	Start bit	1	1	1	Data bit	7	7 (8) Selectable	8	Parity	Even	Even (No parity, Odd) Selectable	No parity (Even, Odd) Selectable	Stop bit	1	1 (2) Selectable	1 (2) Selectable
Communication protocol	Shinko protocol	Modbus ASCII	Modbus RTU																		
Start bit	1	1	1																		
Data bit	7	7 (8) Selectable	8																		
Parity	Even	Even (No parity, Odd) Selectable	No parity (Even, Odd) Selectable																		
Stop bit	1	1 (2) Selectable	1 (2) Selectable																		
External setting input (EIT option)	<p>SV adds external analog signal to remote bias value. Not available for Program control. Setting signal: 4 to 20 mA DC Allowable input: 50 mA DC max. Input impedance: 50 Ω max. Input sampling period: 125 ms</p>																				
Transmission output (EIT option)	<p>Converting the value (PV, SV, MV or DV transmission) to analog signal every 125 ms, outputs the value in current or voltage. Outputs Transmission output low limit value if Transmission output high limit and low limit value are the same. Resolution: 12000 Output: 4 to 20 mA DC (Load resistance: Maximum 550 Ω) Output accuracy: Within ±0.3% of Transmission output span</p>																				
Insulated power output (P24 option)	<p>Output voltage: 24 ± 3 V DC (when load current is 30 mA DC) Ripple voltage: Within 200 mV DC (when load current is 30 mA DC) Max. load current: 30 mA DC</p>																				

12. Troubleshooting

If any malfunctions occur, refer to the following items after checking that power is being supplied to the controller.

12.1 Indication

Problem	Possible Cause	Solution
The PV Display indicates [E r 0 1].	Internal non-volatile IC memory is defective.	Cancel the error code by pressing the  key, and perform data clearing. (p.108) If the problem is not still solved, contact our agency or us.
The PV Display indicates [E r 0 2].	Data writing (in non-volatile IC memory) error when power failure occurs.	Cancel the error code by pressing the  key, and perform data clearing. (p.108)
The PV Display indicates PV and [E r 0 5] (*) alternately.	Overscale. PV has exceeded Input range high limit value (scaling high limit value for DC voltage, current inputs).	Check the input signal source.
The PV Display indicates PV and [E r 0 6] (*) alternately.	Underscale. PV has dropped below Input range low limit value (scaling low limit value for DC voltage, current inputs).	Check the input signal source and wiring of input terminals.
The PV Display indicates [- - - -].	PV has exceeded the Indication range and Control range.	Check the input signal source.
The PV Display indicates [- - - -] and [E r 0 7] (*) alternately.	Burnout of thermocouple, RTD or disconnection of DC voltage (0 to 1 V DC)	Replace each sensor. How to check whether the sensor is burnt out [Thermocouple] If the input terminals of the instrument are shorted, and if a value around room temperature is indicated, the instrument is likely to be operating normally, however, the sensor may be burnt out. [RTD] If approx. 100 Ω of resistance is connected to the input terminals between A-B of the instrument and between B-B is shorted, and if a value around 0°C (32°F) is indicated, the instrument is likely to be operating normally, however, the sensor may be burnt out. [DC voltage (0 to 1 V DC)] If the input terminals of the instrument are shorted, and if a scaling low limit value is indicated, the instrument is likely to be operating normally, however, the signal wire may be disconnected.
	Check whether the input terminals of thermocouple, RTD or DC voltage (0 to 1 V DC) are securely mounted to the instrument input terminals.	Connect the sensor terminals to the instrument input terminals securely.

(*) Displayed when Enabled is selected in [Error indication Enabled/Disabled].

Problem	Possible Cause	Solution
The PV Display indicates [- - - -].	PV has dropped below the Indication range and Control range.	Check the input signal source and wiring of input terminals.
The PV Display indicates [- - - -] and [E r 7] (*) alternately.	Check whether input signal wire for DC voltage (1 to 5 V DC) or direct current (4 to 20 mA DC) is disconnected.	<p>How to check whether the input signal wire is disconnected</p> <p>[DC voltage (1 to 5 V DC)] If the input to the input terminals of the instrument is 1 V DC and if a scaling low limit value is indicated, the instrument is likely to be operating normally, however, the signal wire may be disconnected.</p> <p>[Direct current (4 to 20 mA DC)] If the input to the input terminals of the instrument is 4 mA DC and if a scaling low limit value is indicated, the instrument is likely to be operating normally, however, the signal wire may be disconnected.</p>
	Check whether input signal wire for DC voltage (1 to 5 V DC) or current (4 to 20 mA DC) is securely connected to the instrument input terminals.	Connect the input signal wire to the terminals of this instrument securely.
	Check if polarity of thermocouple or compensating lead wire is correct. Check whether codes (A, B, B) of RTD agree with the instrument terminals.	Wire them correctly.
The PV Display indicates [E r 10].	Hardware malfunction	Contact our agency or us.
The PV Display indicates [FF], nothing or PV.	Control output OFF function is enabled.	Press the © key for approx. 1 second to cancel the function.
The indication of PV Display is irregular or unstable.	Check whether sensor input or temperature unit (°C or °F) is correct.	Select the sensor input and temperature unit (°C or °F) correctly.
	Sensor correction coefficient or Sensor correction value is unsuitable.	Set them to suitable values.
	Check whether the sensor specification is correct.	Use a sensor with appropriate specifications.
	AC leaks into the sensor circuit.	Use an ungrounded type sensor.
	There may be equipment that interferes with or makes noise near the instrument.	Keep the instrument clear of any potentially disruptive equipment.

(*) Displayed when Enabled is selected in [Error indication Enabled/Disabled].

Problem	Possible Cause	Solution
The PV Display keeps indicating the value set in [Scaling low limit].	Check whether the input signal wire for DC voltage (0 to 5 V DC, 0 to 10 V DC) and direct current (0 to 20 mA DC) is disconnected.	Check the input signal wires of DC voltage (0 to 5 V DC, 0 to 10 V DC) and direct current (0 to 20 mA DC). How to check whether the input signal wire is disconnected [DC voltage (0 to 5 V DC, 0 to 10 V DC)] If the input to the input terminal of this controller is 1 V DC, and if a value (converted value from scaling high, low limit setting) corresponding to 1 V DC is indicated, the controller is likely to be operating normally, however, the input signal wire may be disconnected. [Direct current (0 to 20 mA DC)] If the input to the input terminal of this controller is 4 mA DC, and if a value (converted value from scaling high, low limit setting) corresponding to 4 mA DC is indicated, the controller is likely to be operating normally, however, the input signal wire may be disconnected.
	Check whether the input terminals for DC voltage (0 to 5 V DC, 0 to 10 V DC) or direct current (0 to 20 mA DC) are securely connected to the instrument input terminals.	Connect the input terminals of DC voltage and current to the input terminals of this instrument securely.

12.2 Key Operation

Problem	Possible Cause	Solution
None of the set values can be set.	Set value lock (Lock 1 or Lock 4) is selected.	Release the lock in [Set value lock].
	AT, 'AT on startup' or Auto-reset is performing.	If AT or 'AT on startup' is performing, cancel AT or 'AT on startup'. Please wait until Auto-reset is finished. (It takes approximately 4 minutes until Auto-reset is finished.)
Only SV and Alarm value can be set. Other settings are impossible.	Set value lock (Lock 2 or Lock 5) is selected.	Release the lock in [Set value lock].
The setting indication does not change in the input range, and new values are unable to be set.	Scaling high or low limit value may be set at the point where the value does not change.	Set it to a suitable value.

12.3 Control

Problem	Possible Cause	Solution
Temperature does not rise.	Sensor is out of order.	Replace the sensor.
	Check whether the sensor or control output terminals are securely mounted to the instrument input terminals.	Ensure that the sensor or control output terminals are mounted to the instrument input terminals securely.
	Check whether the wiring of sensor or control output terminals is correct.	Wire them correctly.
The control output remains in an ON status.	OUT1 (or OUT2) low limit value is set to 100% or higher.	Set it to a suitable value.
The control output remains in an OFF status.	OUT1 (or OUT2) high limit value is set to 0% or less.	Set it to a suitable value.
The PV display indicates [E-20].	AT or 'AT on startup' has not been completed even if approx. 4 hours have elapsed since AT or 'AT on startup' started.	Set P, I, D and ARW values manually
	For 'AT on startup', PV slope and delay time cannot be measured normally for P, I, D calculation.	

For all other malfunctions, please contact our main office or dealers.

13. Character Table

13.1 Error Code

Error codes are indicated on the PV Display.

Error Code	Error Contents	Occurrence
Er01	Internal non-volatile IC memory is defective.	When power is turned ON.
Er02	Data writing (in non-volatile IC memory) error when power failure occurs.	When power is turned ON.
Er05 (*)	PV has exceeded Input range high limit value (Scaling high limit value for DC voltage, current inputs).	When operating
Er06 (*)	PV has dropped below Input range low limit value (Scaling low limit value for DC voltage, current inputs).	When operating
Er07 (*)	Input burnout or disconnection. Input value is outside of the Indication range and control range.	When operating
Er10	Hardware malfunction	When operating
Er20	AT or 'AT on startup' has not been completed even if approx. 4 hours have elapsed since AT or 'AT on startup' started. For 'AT on startup', PV slope and delay time cannot be measured normally for P, I, D calculation.	When AT or 'AT on startup' starts

(*) Displayed when Enabled is selected in [Error indication Enabled/Disabled].

13.2 Run Mode

Character	Indicated Item Name
OFF 000	Control output OFF
25 105	Manual control (MV flashes.)

13.3 Monitor Mode

The PV Display indicates PV, and the SV Display indicates setting item value.

Character	Indicated Item Name
25 [MV]	MV (Decimal point flashes.)
25 [Remaining time]	Remaining time (When Program control is performing)
25 [Step number]	Current step number (When Program control is performing) (BCS2) 47_1 to 47_9
25 [Memory number]	SV number (BCS2) 48 1 to 484

13.4 Initial Setting Mode

The PV Display (upper row) indicates setting characters, and the SV Display (lower row) indicates factory default value.

Characters, Factory Default	Setting Item, Setting Range					
4E74 E000	Input type					
	E000	K	-200 to 1370°C	E00F	K	-328 to 2498°F
	E0.0	K	-200.0 to 400.0°C	E0.F	K	-328.0 to 752.0°F
	J000	J	-200 to 1000°C	J00F	J	-328 to 1832°F
	r000	R	0 to 1760°C	r00F	R	32 to 3200°F
	4000	S	0 to 1760°C	400F	S	32 to 3200°F
	b000	B	0 to 1820°C	b00F	B	32 to 3308°F
	E000	E	-200 to 800°C	E00F	E	-328 to 1472°F
	r0.0	T	-200.0 to 400.0°C	r0.F	T	-328.0 to 752.0°F
	n000	N	-200 to 1300°C	n00F	N	-328 to 2372°F
	PL20	PL-II	0 to 1390°C	PL2F	PL-II	32 to 2534°F
	c000	C(W/Re5-26)	0 to 2315°C	c00F	C(W/Re5-26)	32 to 4199°F
	Pt1.0	Pt100	-200.0 to 850.0°C	Pt1.F	Pt100	-328.0 to 1562.0°F
	JPt1.0	JPt100	-200.0 to 500.0°C	JPt1.F	JPt100	-328.0 to 932.0°F
	Pt100	Pt100	-200 to 850°C	Pt100F	Pt100	-328 to 1562°F
	JPt100	JPt100	-200 to 500°C	JPt100F	JPt100	-328 to 932°F
	420A	4 to 20 mA DC -2000 to 10000				
	020A	0 to 20 mA DC -2000 to 10000				
001V	0 to 1 V DC -2000 to 10000					
005V	0 to 5 V DC -2000 to 10000					
105V	1 to 5 V DC -2000 to 10000					
010V	0 to 10 V DC -2000 to 10000					
4FLH 1370	Scaling high limit Setting range: Scaling low limit value to input range high limit value DC voltage, current inputs: -2000 to 10000 (*1)					
4FLl -200	Scaling low limit Setting range: Input range low limit value to scaling high limit value DC voltage, current inputs: -2000 to 10000 (*1)					
dP00 0000	Decimal point place					
	0000	No decimal point				
	0000	1 digit after decimal point				
	0000	2 digits after decimal point				
	0000	3 digits after decimal point				

(*1) The placement of the decimal point follows the selection.

Characters, Factory Default	Setting Item, Setting Range	
E801 000	Event output EV1 allocation [Event Output Allocation Table]	
	000	No event
	001	Alarm output, High limit alarm
	002	Alarm output, Low limit alarm
	003	Alarm output, High/Low limits alarm
	004	Alarm output, High/Low limits independent alarm
	005	Alarm output, High/Low limit range alarm
	006	Alarm output, High/Low limit range independent alarm
	007	Alarm output, Process high alarm
	008	Alarm output, Process low alarm
	009	Alarm output, High limit with standby alarm
	010	Alarm output, Low limit with standby alarm
	011	Alarm output, High/Low limits with standby alarm
	012	Alarm output, High/Low limits with standby independent alarm
	013	Heater burnout alarm output
	014	Loop break alarm output
	015	Time signal output
	016	Output during AT
017	Pattern end output	
018	Output by communication command	
R13R no	EV1 alarm value 0 Enabled/Disabled	
	no	Disabled
	YE4	Enabled
R10 000	EV1 alarm value	
	High limit alarm	-(Input span) to Input span °C (°F) (*1) (*2)
	Low limit alarm	-(Input span) to Input span °C (°F) (*1) (*2)
	High/Low limits alarm	0 to Input span °C (°F) (*1) (*2)
	High/Low limits independent alarm	0 to Input span °C (°F) (*1) (*2)
	High/Low limit range alarm	0 to Input span °C (°F) (*1) (*2)
	High/Low limit range independent alarm	0 to Input span °C (°F) (*1) (*2)
	Process high alarm	Input range low limit to Input range high limit (*1) (*3)
	Process low alarm	Input range low limit to Input range high limit (*1) (*3)
	High limit with standby alarm	-(Input span) to Input span °C (°F) (*1) (*2)
	Low limit with standby alarm	-(Input span) to Input span °C (°F) (*1) (*2)
	High/Low limits with standby alarm	0 to Input span °C (°F) (*1) (*2)
High/Low limits with standby independent alarm	0 to Input span °C (°F) (*1) (*2)	
R14 000	EV1 high limit alarm value Setting range: Same as those of EV1 alarm value	

(*1) The placement of the decimal point follows the selection.

(*2) For DC voltage, current inputs, the input span is the same as the scaling span.

(*3) For DC voltage, current inputs, input range low (or high) limit value is the same as scaling low (or high) limit value.

Characters, Factory Default	Setting Item, Setting Range	
R 143 □□ 10	EV1 alarm hysteresis Setting range: 0.1 to 1000.0°C(°F), DC voltage, current inputs: 1 to 10000 (*1)	
R 1d3 □□□□	EV1 alarm delay time Setting range: 0 to 10000 seconds	
R 1Lā noāL	EV1 alarm Energized/De-energized	
	noāL	Energized
	rEB4	De-energized
F4 14 □□□ 1	TS1 output step number Setting range: 1 to 9	
F4 1F □□□□	TS1 OFF time Setting range: 00:00 to 99:59 (*4)	
F4 1o □□□□	TS1 ON time Setting range: 00:00 to 99:59 (*4)	
EB02 □□□□	Event output EV2 allocation [Event Output Allocation Table]	
	□□□□	No event
	□□□ 1	Alarm output, High limit alarm
	□□□ 2	Alarm output, Low limit alarm
	□□□ 3	Alarm output, High/Low limits alarm
	□□□ 4	Alarm output, High/Low limits independent alarm
	□□□ 5	Alarm output, High/Low limit range alarm
	□□□ 6	Alarm output, High/Low limit range independent alarm
	□□□ 7	Alarm output, Process high alarm
	□□□ 8	Alarm output, Process low alarm
	□□□ 9	Alarm output, High limit with standby alarm
	□□ 10	Alarm output, Low limit with standby alarm
	□□ 11	Alarm output, High/Low limits with standby alarm
	□□ 12	Alarm output, High/Low limits with standby independent alarm
	□□ 13	Heater burnout alarm output
	□□ 14	Loop break alarm output
	□□ 15	Time signal output
	□□ 16	Output during AT
	□□ 17	Pattern end output
	□□ 18	Output by communication command
	□□ 19	Heating/Cooling control relay contact output
R23A no□□	EV2 alarm value 0 Enabled/Disabled	
	no□□	Disabled
	4E4□	Enabled

(*1) The placement of the decimal point follows the selection.

(*4) Time unit follows the selection in [Step time unit].

Characters, Factory Default	Setting Item, Setting Range	
R200 0000	EV2 alarm value	
	High limit alarm	-(Input span) to Input span °C (°F) (*1)(*2)
	Low limit alarm	-(Input span) to Input span °C (°F) (*1)(*2)
	High/Low limits alarm	0 to Input span °C (°F) (*1)(*2)
	High/Low limits independent alarm	0 to Input span °C (°F) (*1)(*2)
	High/Low limit range alarm	0 to Input span °C (°F) (*1)(*2)
	High/Low limit range independent alarm	0 to Input span °C (°F) (*1)(*2)
	Process high alarm	Input range low limit to Input range high limit (*1)(*3)
	Process low alarm	Input range low limit to Input range high limit (*1)(*3)
	High limit with standby alarm	-(Input span) to Input span °C (°F) (*1)(*2)
	Low limit with standby alarm	-(Input span) to Input span °C (°F) (*1)(*2)
	High/Low limits with standby alarm	0 to Input span °C (°F) (*1)(*2)
	High/Low limits with standby independent alarm	0 to Input span °C (°F) (*1)(*2)
R2H0 0000	EV2 high limit alarm value Setting range: Same as those of EV2 alarm value	
R2H4 00.10	EV2 alarm hysteresis Setting range: 0.1 to 1000.0°C (°F), DC voltage, current inputs: 1 to 10000 (*1)	
R2d4 0000	EV2 alarm delay time Setting range: 0 to 10000 seconds	
R2Lā noāL	EV2 alarm Energized/De-energized	
	noāL	Energized
	rEB4	De-energized
F424 0001	TS2 output step number Setting range: 1 to 9	
F42F 0000	TS2 OFF time Setting range: 00:00 to 99:59 (*4)	
F42o 0000	TS2 ON time Setting range: 00:00 to 99:59 (*4)	
H100 0000 H1 and CT1 current value are alternately indicated on the PV Display.	Heater burnout alarm 1 value Setting range: 20 A: 0.0 to 20.0 A 100 A: 0.0 to 100.0 A	
	Heater burnout alarm 2 value Setting range: 20 A: 0.0 to 20.0 A 100 A: 0.0 to 100.0 A	

(*1) The placement of the decimal point follows the selection.

(*2) For DC voltage, current inputs, the input span is the same as the scaling span.

(*3) For DC voltage, current inputs, input range low (or high) limit value is the same as scaling low (or high) limit value.

(*4) Time unit follows the selection in [Step time unit].

Characters, Factory Default	Setting Item, Setting Range			
LP_T □□□□	Loop break alarm time Setting range: 0 to 200 minutes			
LP_H □□□□	Loop break alarm span Setting range: 0 to 150°C (°F), or 0.0 to 150.0°C (°F) DC voltage, current inputs: 0 to 1500 (*1)			
EB1 1 □□□□	Event input DI1 allocation [Event Input Allocation Table]			
		Event input function	Input ON (Closed)	Input OFF (Open)
	□□□□	No event		
	□□□□	Set value memory		
	□□□□	Control ON/OFF	Control OFF	Control ON
	□□□□	Direct/Reverse action	Direct action	Reverse action
	□□□□	Preset output 1 ON/OFF	Preset output	Usual control
	□□□□	Preset output 2 ON/OFF	Preset output	Usual control
	□□□□	Auto/Manual control	Manual control	Automatic control
	□□□□	Remote/Local	Remote	Local
	□□□□	Program control RUN/STOP	RUN	STOP
	□□□□	Program control Holding/Not holding	Holding	Not holding
	□□□□	Program control Advance function	Advance function	Usual control
□□□□	Integral action Holding	Integral action Holding	Usual integral action	
EB1 2 □□□□	Event input DI2 allocation Selection item: Same as those of Event input DI1 allocation			
rFLH 1370	External setting input high limit Setting range: External setting input low limit to Input range high limit (*1)			
rFLl -200	External setting input low limit Setting range: Input range low limit to External setting input high limit (*1)			
Trout PB□□	Transmission output type			
	PB□□	PV transmission		
	4B□□	SV transmission		
	7B□□	MV transmission		
	dB□□	DV transmission		







(*1) The placement of the decimal point follows the selection.

Characters, Factory Default	Setting Item, Setting Range	
FFLH 1370	Transmission output high limit	
	PV, SV transmission	Transmission output low limit to Input range high limit DC voltage, currents: -2000 to 10000
	MV transmission	Transmission output low limit to 105.0%
	DV transmission	Transmission output low limit to Scaling span (*1)
FFL -200	Transmission output low limit	
	PV, SV transmission	Input range low limit to Transmission output high limit DC voltage, currents: -2000 to 10000
	MV transmission	-5.0% to Transmission output high limit value
	DV transmission	-Scaling span to Transmission output high limit value (*1)
400 000	SV1 Setting range: Scaling low limit to Scaling high limit (*1)	
420 000	SV2 Setting range: Scaling low limit to Scaling high limit (*1)	
430 000	SV3 Setting range: Scaling low limit to Scaling high limit (*1)	
440 000	SV4 Setting range: Scaling low limit to Scaling high limit (*1)	

(*1) The placement of the decimal point follows the selection.

13.5 Main Setting Mode

The PV Display (upper row) indicates setting characters, and the SV Display (lower row) indicates factory default value.

Characters, Factory Default	Setting Item, Setting Range
4000 0000	SV1 Setting range: Scaling low limit to Scaling high limit (*1)
r0.1 0000	Step 1 time Setting range:  , or 00:00 to 99:59
20.1 0000	Step 1 wait value Setting range: 0 to 20% of input span DC voltage, current inputs: 0 to 20% of scaling span (*1)
4200 0000	SV2 Setting range: Scaling low limit to Scaling high limit (*1)
r0.2 0000	Step 2 time Setting range:  , or 00:00 to 99:59
20.2 0000	Step 2 wait value Setting range: 0 to 20% of input span DC voltage, current inputs: 0 to 20% of scaling span (*1)
4300 0000	SV3 Setting range: Scaling low limit to Scaling high limit (*1)
r0.3 0000	Step 3 time Setting range:  , or 00:00 to 99:59
20.3 0000	Step 3 wait value Setting range: 0 to 20% of input span DC voltage, current inputs: 0 to 20% of scaling span (*1)
4400 0000	SV4 Setting range: Scaling low limit to Scaling high limit (*1)
r0.4 0000	Step 4 time Setting range:  , or 00:00 to 99:59
20.4 0000	Step 4 wait value Setting range: 0 to 20% of input span DC voltage, current inputs: 0 to 20% of scaling span (*1)
4500 0000	Step 5 SV Setting range: Scaling low limit to Scaling high limit (*1)
r0.5 0000	Step 5 time Setting range:  , or 00:00 to 99:59
20.5 0000	Step 5 wait value Setting range: 0 to 20% of input span DC voltage, current inputs: 0 to 20% of scaling span (*1)
4600 0000	Step 6 SV Setting range: Scaling low limit to Scaling high limit (*1)
r0.6 0000	Step 6 time Setting range:  , or 00:00 to 99:59
20.6 0000	Step 6 wait value Setting range: 0 to 20% of input span DC voltage, current inputs: 0 to 20% of scaling span (*1)

(*1) The placement of the decimal point follows the selection.

Characters, Factory Default	Setting Item, Setting Range
47.0 0.00	Step 7 SV Setting range: Scaling low limit to Scaling high limit (*1)
r0.7 00.00	Step 7 time Setting range: <input type="text" value="00:00"/> , or 00:00 to 99:59
20.7 0.00	Step 7 wait value Setting range: 0 to 20% of input span DC voltage, current inputs: 0 to 20% of scaling span (*1)
48.0 0.00	Step 8 SV Setting range: Scaling low limit to Scaling high limit (*1)
r0.8 00.00	Step 8 time Setting range: <input type="text" value="00:00"/> , or 00:00 to 99:59
20.8 0.00	Step 8 wait value Setting range: 0 to 20% of input span DC voltage, current inputs: 0 to 20% of scaling span (*1)
49.0 0.00	Step 9 SV Setting range: Scaling low limit to Scaling high limit (*1)
r0.9 00.00	Step 9 time Setting range: <input type="text" value="00:00"/> , or 00:00 to 99:59
20.9 0.00	Step 9 wait value Setting range: 0 to 20% of input span DC voltage, current inputs: 0 to 20% of scaling span (*1)

(*1) The placement of the decimal point follows the selection.

13.6 Sub Setting Mode

The PV Display (upper row) indicates setting characters, and the SV Display (lower row) indicates factory default value.

Characters, Factory Default	Setting Item, Setting Range	
AT <input type="text"/> <input type="text"/>	AT/Auto-reset Perform/Cancel	
	<input type="text"/>	AT/AT on startup/Auto-reset Cancel
	AT <input type="text"/>	AT Perform
	AT <input type="text"/>	AT on startup Perform
	Auto-reset <input type="text"/>	Auto-reset Perform
P <input type="text"/> <input type="text"/>	OUT1 proportional band Thermocouple, RTD input without decimal point: 0 to Input span °C(°F) Thermocouple, RTD input with decimal point: 0.0 to Input span °C(°F) DC voltage, current inputs: 0.0 to 1000.0%	
I <input type="text"/> <input type="text"/>	Integral time Setting range: 0 to 3600 seconds	
d <input type="text"/> <input type="text"/>	Derivative time Setting range: 0 to 1800 seconds	
AR <input type="text"/> <input type="text"/>	ARW Setting range: 0 to 100%	
Auto-reset <input type="text"/> <input type="text"/>	Manual reset Setting range: ±Proportional band value	
c <input type="text"/> <input type="text"/>	OUT1 proportional cycle Setting range: 0.5, or 1 to 120 seconds Factory default value: • Relay contact output: 30 sec • Non-contact voltage output: 3 sec	
HY <input type="text"/> <input type="text"/>	OUT1 ON/OFF hysteresis Setting range: 0.1 to 1000.0°C (°F) DC voltage, current inputs: 1 to 10000 (*1)	
oLH <input type="text"/> <input type="text"/>	OUT1 high limit Setting range: OUT1 low limit value to 100% (Direct current output type: OUT1 low limit value to 105%)	
oLL <input type="text"/> <input type="text"/>	OUT1 low limit Setting range: 0% to OUT1 high limit value (Direct current output type: -5% to OUT1 high limit value)	
oRAT <input type="text"/> <input type="text"/>	OUT1 rate-of-change Setting range: 0 to 100 %/second	
cRcT <input type="text"/> AI <input type="text"/>	OUT2 cooling method	
	AI <input type="text"/>	Air cooling (linear characteristics)
	oL <input type="text"/>	Oil cooling (1.5th power of the linear characteristics)
	WAT <input type="text"/>	Water cooling (2nd power of the linear characteristics)
P_b <input type="text"/> <input type="text"/>	OUT2 proportional band Thermocouple, RTD input without decimal point: 0 to Input span°C (°F) Thermocouple, RTD input with decimal point: 0.0 to Input span°C (°F) DC voltage, current inputs: 0.0 to 1000.0%	
c_b <input type="text"/> <input type="text"/>	OUT2 proportional cycle Setting range: 0.5, or 1 to 120 seconds Factory default value: • EV2(*2), EV2+DR: 30 sec • DS, EV2+DS: 3 sec	
HY <input type="text"/> <input type="text"/>	OUT2 ON/OFF hysteresis Setting range: 0.1 to 1000.0°C (°F), DC voltage, current inputs: 1 to 10000 (*1)	

(*1) The placement of the decimal point follows the selection.

(*2) When EV2 is selected { 19 (Heating/Cooling control relay contact output) is selected in [Event output EV2 allocation]}.

Characters, Factory Default	Setting Item, Setting Range	
<i>oLHb</i> □ 100	OUT2 high limit Setting range: OUT2 low limit value to 100% (Direct current output type: OUT2 low limit value to 105%)	
<i>oLLb</i> □□□□	OUT2 low limit Setting range: 0% to OUT2 high limit value (Direct current output type: -5% to OUT2 high limit value)	
<i>db□□</i> □□□□	Overlap/Dead band Setting range: -200.0 to 200.0°C (°F), DC voltage, current inputs: -2000 to 2000 (*1)	
<i>conf</i> <i>HEAT</i>	Direct/Reverse action	
	<i>HEAT</i>	Reverse (Heating) action
	<i>COOL</i>	Direct (Cooling) action
<i>RI□□</i> □□□□	EV1 alarm value	
	High limit alarm	-(Input span) to Input span °C (°F) (*1) (*2)
	Low limit alarm	-(Input span) to Input span °C (°F) (*1) (*2)
	High/Low limits alarm	0 to Input span °C (°F) (*1) (*2)
	High/Low limits independent	0 to Input span °C (°F) (*1) (*2)
	High/Low limit range alarm	0 to Input span °C (°F) (*1) (*2)
	High/Low limit range independent alarm	0 to Input span °C (°F) (*1) (*2)
	Process high alarm	Input range low limit to Input range high limit (*1) (*3)
	Process low alarm	Input range low limit to Input range high limit (*1) (*3)
	High limit with standby alarm	-(Input span) to Input span °C (°F) (*1) (*2)
	Low limit with standby alarm	-(Input span) to Input span °C (°F) (*1) (*2)
	High/Low limits with standby	0 to Input span °C (°F) (*1) (*2)
High/Low limits with standby independent alarm	0 to Input span °C (°F) (*1) (*2)	
<i>RIH□</i> □□□□	EV1 high limit alarm value Setting range: Same as those of EV1 alarm value	
<i>RI□□</i> □□□□	EV2 alarm value Setting range: Same as those of EV1 alarm value	
<i>RIH□</i> □□□□	EV2 high limit alarm value Setting range: Same as those of EV1 alarm value	
<i>H1□□</i> □□□□ <i>H1</i> and CT1 current value are alternately indicated on the PV Display.	Heater burnout alarm 1 value Setting range: 20 A: 0.0 to 20.0 A 100 A: 0.0 to 100.0 A	
<i>H2□□</i> □□□□ <i>H2</i> and CT2 current value are alternately indicated on the PV Display.	Heater burnout alarm 2 value Setting range: 20 A: 0.0 to 20.0 A 100 A: 0.0 to 100.0 A	
<i>LP_T</i> □□□□	Loop break alarm time Setting range: 0 to 200 minutes	
<i>LP_H</i> □□□□	Loop break alarm span Thermocouple, RTD input without decimal point: 0 to 150°C (°F) Thermocouple, RTD input with decimal point: 0.0 to 150.0°C (°F) DC voltage, current inputs: 0 to 1500 (*1)	

(*1) The placement of the decimal point follows the selection.

(*2) For DC voltage, current inputs, the input span is the same as the scaling span.

(*3) For DC voltage, current inputs, input range low (or high) limit value is the same as scaling low (or high) limit value.

13.7 Engineering Mode 1

The PV Display (upper row) indicates setting characters, and the SV Display (lower row) indicates factory default value.

Characters, Factory Default	Setting Item, Setting Range			
Lock - - - -	Set value lock			
			Change via Keypad	Change via Software Communication
	- - - -	Unlock	All set values can be changed.	All set values can be changed.
	Loc 1	Lock 1	None of the set values can be changed.	
	Loc 2	Lock 2	In Fixed value control, only SV and Alarm value can be changed. In Program control, Step SV, Step time and Alarm value can be changed.	
	Loc 3	Lock 3	All set values can be changed.	Setting items – except Input type, Controller/Converter – can be changed temporarily via software communication. However, if power is turned ON again, the set values revert to the values before Lock 3, 4 or 5 was selected.
	Loc 4	Lock 4	None of the set values can be changed.	
	Loc 5	Lock 5	In Fixed value control, only SV and Alarm value can be changed. In Program control, Step SV, Step time and Alarm value can be changed.	
EBI 1 0000	Event input DI1 allocation [Event Input Allocation Table]			
		Event input function	Input ON (Closed)	Input OFF (Open)
	0000	No event		
	0001	Set value memory		
	0002	Control ON/OFF	Control OFF	Control ON
	0003	Direct/Reverse action	Direct action	Reverse action
	0004	Preset output 1 ON/OFF	Preset output	Usual control
	0005	Preset output 2 ON/OFF	Preset output	Usual control
	0006	Auto/Manual control	Manual control	Automatic control
	0007	Remote/Local	Remote	Local
	0008	Program control RUN/STOP	RUN	STOP
	0009	Program control Holding/Not holding	Holding	Not holding
	0010	Program control Advance function	Advance function	Usual control
0011	Integral action holding	Integral action holding	Usual integral action	

Characters, Factory Default	Setting Item, Setting Range	
EV1 2 000	Event input DI2 allocation Selection item: Same as Event input DI1 allocation	
EV0 1 000	Event output EV1 allocation [Event Output Allocation Table]	
	000	No event
	001	Alarm output, High limit alarm
	002	Alarm output, Low limit alarm
	003	Alarm output, High/Low limits alarm
	004	Alarm output, High/Low limits independent alarm
	005	Alarm output, High/Low limit range alarm
	006	Alarm output, High/Low limit range independent alarm
	007	Alarm output, Process high alarm
	008	Alarm output, Process low alarm
	009	Alarm output, High limit with standby alarm
	010	Alarm output, Low limit with standby alarm
	011	Alarm output, High/Low limits with standby alarm
	012	Alarm output, High/Low limits with standby independent alarm
	013	Heater burnout alarm output
	014	Loop break alarm output
	015	Time signal output
	016	Output during AT
	017	Pattern end output
	018	Output by communication command
AEAR no	EV1 alarm value 0 Enabled/Disabled	
	no	Disabled
	YE4	Enabled
AE 000	EV1 alarm value	
	High limit alarm	-(Input span) to Input span °C (°F) (*1) (*2)
	Low limit alarm	-(Input span) to Input span °C (°F) (*1) (*2)
	High/Low limits alarm	0 to Input span °C (°F) (*1) (*2)
	High/Low limits independent alarm	0 to Input span °C (°F) (*1) (*2)
	High/Low limit range alarm	0 to Input span °C (°F) (*1) (*2)
	High/Low limit range independent alarm	0 to Input span °C (°F) (*1) (*2)
	Process high alarm	Input range low limit to Input range high limit (*1) (*3)
	Process low alarm	Input range low limit to Input range high limit (*1) (*3)
	High limit with standby alarm	-(Input span) to Input span °C (°F) (*1) (*2)
	Low limit with standby alarm	-(Input span) to Input span °C (°F) (*1) (*2)
	High/Low limits with standby alarm	0 to Input span °C (°F) (*1) (*2)
	High/Low limits with standby independent alarm	0 to Input span °C (°F) (*1) (*2)
AEH 000	EV1 high limit alarm value Setting range: Same as those of EV1 alarm value	

(*1) The placement of the decimal point follows the selection.

(*2) For DC voltage, current inputs, the input span is the same as the scaling span.

(*3) For DC voltage, current inputs, input range low (or high) limit value is the same as scaling low (or high) limit value.

Characters, Factory Default	Setting Item, Setting Range	
R 144 □□ 10	EV1 alarm hysteresis Setting range: 0.1 to 1000.0°C (°F), DC voltage, current inputs: 1 to 10000 (*1)	
R 1d4 □□□□	EV1 alarm delay time Setting range: 0 to 10000 seconds	
R 1Lā noāL	EV1 alarm Energized/De-energized	
	noāL	Energized
	rEā4	De-energized
F4 14 □□□ 1	TS1 output step number Setting range: 1 to 9	
F4 1F 0000	TS1 OFF time Setting range: 00:00 to 99:59 (*2)	
F4 1o 0000	TS1 ON time Setting range: 00:00 to 99:59 (*2)	
E8o2 □□□□	Event output EV2 allocation [Event Output Allocation Table]	
	□□□□	No event
	□□□ 1	Alarm output, High limit alarm
	□□□ 2	Alarm output, Low limit alarm
	□□□ 3	Alarm output, High/Low limits alarm
	□□□ 4	Alarm output, High/Low limits independent alarm
	□□□ 5	Alarm output, High/Low limit range alarm
	□□□ 6	Alarm output, High/Low limit range independent alarm
	□□□ 7	Alarm output, Process high alarm
	□□□ 8	Alarm output, Process low alarm
	□□□ 9	Alarm output, High limit with standby alarm
	□□ 10	Alarm output, Low limit with standby alarm
	□□ 11	Alarm output, High/Low limits with standby alarm
	□□ 12	Alarm output, High/Low limits with standby independent alarm
	□□ 13	Heater burnout alarm output
	□□ 14	Loop break alarm output
	□□ 15	Time signal output
	□□ 16	Output during AT
	□□ 17	Pattern end output
	□□ 18	Output by communication command
	□□ 19	Heating/Cooling control relay contact output
R2E4 no□□	EV2 alarm value 0 Enabled/Disabled	
	no□□	Disabled
	4E4□	Enabled

(*1) The placement of the decimal point follows the selection.

(*2) Time unit follows the selection in [Step time unit].

Characters, Factory Default	Setting Item, Setting Range	
R200 0000	EV2 alarm value	
	High limit alarm	-(Input span) to Input span °C (°F) (*1) (*2)
	Low limit alarm	-(Input span) to Input span °C (°F) (*1) (*2)
	High/Low limits alarm	0 to Input span °C (°F) (*1) (*2)
	High/Low limits independent alarm	0 to Input span °C (°F) (*1) (*2)
	High/Low limit range alarm	0 to Input span °C (°F) (*1) (*2)
	High/Low limit range independent alarm	0 to Input span °C (°F) (*1) (*2)
	Process high alarm	Input range low limit to Input range high limit (*1) (*3)
	Process low alarm	Input range low limit to Input range high limit (*1) (*3)
	High limit with standby alarm	-(Input span) to Input span °C (°F) (*1) (*2)
	Low limit with standby alarm	-(Input span) to Input span °C (°F) (*1) (*2)
	High/Low limits with standby alarm	0 to Input span °C (°F) (*1) (*2)
High/Low limits with standby independent alarm	0 to Input span °C (°F) (*1) (*2)	
R2H0 0000	EV2 high limit alarm value Setting range: Same as those of EV2 alarm value	
R2HY 00 10	EV2 alarm hysteresis Setting range: 0.1 to 1000.0°C (°F), DC voltage, current inputs: 1 to 10000 (*1)	
R2dY 0000	EV2 alarm delay time Setting range: 0 to 10000 seconds	
R2Lā noāL	EV2 alarm Energized/De-energized	
	noāL	Energized
	rEBh	De-energized
r424 0001	TS2 output step number Setting range: 1 to 9	
r42F 0000	TS2 OFF time Setting range: 00:00 to 99:59 (*4)	
r42o 0000	TS2 ON time Setting range: 00:00 to 99:59 (*4)	
4oE0 1000	Sensor correction coefficient Setting range: -10.000 to 10.000	
4o00 0000	Sensor correction Setting range: -1000.0 to 1000.0°C (°F) DC voltage, current inputs: -10000 to 10000 (*1)	
F1LF 0000	PV filter time constant Setting range: 0.0 to 10.0 seconds	
cāhL noāL	Communication protocol	
	noāL	Shinko protocol
	āodā	Modbus ASCII
	āodr	Modbus RTU
	āoāL	Shinko protocol (JC command allocated)
	āodā	Modbus ASCII (JC command allocated)
	āodr	Modbus RTU (JC command allocated)

(*1) The placement of the decimal point follows the selection.

(*2) For DC voltage, current inputs, the input span is the same as the scaling span.

(*3) For DC voltage, current inputs, input range low (or high) limit value is the same as scaling low (or high) limit value.

(*4) Time unit follows the selection in [Step time unit].

Characters, Factory Default	Setting Item, Setting Range	
<i>cñno</i> 0000	Instrument number 0 to 95	
<i>cñ4P</i> 0096	Communication speed	
	0096	9600 bps
	0192	19200 bps
<i>cñFF</i> 7E8n	Data bit/Parity	
	8non	8 bits/No parity
	7non	7 bits/No parity
	8E8n	8 bits/Even
	7E8n	7 bits/Even
	8odd	8 bits/Odd
<i>cñ4F</i> 0001	Stop bit	
	0001	1 bit
	0002	2 bits
<i>cñd4</i> 0010	Response delay time Setting range: 0 to 1000 ms	
<i>4B_b</i> 0000	SVTC bias Setting range: ±20% of the input span DC voltage, current inputs: ±20% of scaling span (*1)	
<i>rEñF</i> LocL	Remote/Local	
	LocL	Local
<i>rFLH</i> 1370	External setting input high limit Setting range: External setting input low limit to Input range high limit	
	External setting input low limit Setting range: Input range low limit to External setting input high limit	
<i>rF_b</i> 0000	Remote bias Setting range: ±20% of input span DC voltage, current inputs: ±20% of scaling span (*1)	
<i>Fro4</i> Pb00	Transmission output type	
	Pb00	PV transmission
	4B00	SV transmission
	ñB00	MV transmission
<i>FrLH</i> 1370	Transmission output high limit	
	PV, SV transmission	Transmission output low limit to Input range high limit value
	MV transmission	Transmission output low limit to 105.0%
	DV transmission	Transmission output low limit to Scaling span (*1)
<i>FrLL</i> -200	Transmission output low limit	
	PV, SV transmission	Input range low limit to Transmission output high limit value
	MV transmission	-5.0% to Transmission output high limit value
	DV transmission	-Scaling span to Transmission output high limit value (*1)

(*1) The placement of the decimal point follows the selection.

Characters, Factory Default	Setting Item, Setting Range	
n_40 n1 n0	Step time unit	
	n1 n0	Hours:Minutes
	4E0	Minutes:Seconds
PrEr 4r0P	Power restore action	
	4r0P	Stops after power is restored
	conr	Continues (resumes) after power is restored.
HoLd	Suspends (on hold) after power is restored.	
4_4B 0000	Program start temperature Setting range: Scaling low limit value to Scaling high limit value (*1)	
4_4L P400	Program control start type	
	P400	PV start
	P4r0	PVR start
4B00	SV start	
rEPF 0000	Number of repetitions Setting range: 0 to 10000 times	
rR44 4B4F	SV Rise/Fall rate start type	
	4B4F	SV start
	P44F	PV start
rRFU 0000	SV rise rate Setting range: 0 to 10000 °C/min (°F/min) Thermocouple, RTD inputs with a decimal point: 0.0 to 1000.0 °C/min (°F/min) DC voltage, current inputs: 0 to 10000/min	
rRFd 0000	SV fall rate Setting range: 0 to 10000 °C/min (°F/min) Thermocouple, RTD inputs with a decimal point: 0.0 to 1000.0 °C/min (°F/min) DC voltage, current inputs: 0 to 10000/min	
P4B0 oFF0	Indication when control output OFF	
	oFF0	OFF indication
	RoFF	No indication
	P400	PV indication
P4AL	PV indication + Any Alarm active	
RF_b 0020	AT bias Setting range: 0 to 50°C (0 to 100°F), or 0.0 to 50.0°C (0.0 to 100.0°F)	
RF_t 00 10	AT gain Setting range: 0.1 to 10.0 times	
EoUF oFF0	Output status when input errors occur	
	oFF0	Output OFF
	on00	Output ON
nAnU oFF0	OUT/OFF key function	
	oFF0	Control output OFF function
	nAnU	Auto/Manual control
PraU	Program control	
nAr4 AUfo	Auto/Manual control after power ON	
	AUfo	Automatic control
	nAnU	Manual control

(*1) The placement of the decimal point follows the selection.

Characters, Factory Default	Setting Item, Setting Range	
<i>P1 AE</i> 0000	Indication time Setting range: 00:00 to 60:00 (Minutes:Seconds) When set to 00:00, Displays remain ON.	
<i>P4 F1</i> 0000	OUT1 MV preset value Setting range: OUT1 low limit to OUT1 high limit For Direct current output type, and when OUT1 is in ON/OFF control: OUT1 low limit or OUT1 high limit For Relay contact output or Non-contact voltage output type, and when OUT1 is in ON/OFF control: 0.0% or 100.0%	
<i>P4 F2</i> 0000	OUT2 MV preset value Setting range: OUT2 low limit to OUT2 high limit For DA, EV2+DA options, and when OUT2 is in ON/OFF control: OUT2 low limit or OUT2 high limit For DR, DS, EV2+DR, EV2+DS options, and when OUT2 is in ON/OFF control: 0.0% or 100.0%	
<i>FUnc</i> <i>cnfr</i>	Controller/Converter function	
	<i>cnfr</i>	Controller
	<i>cnbf</i>	Converter
<i>Edi F</i> no00	Error indication Enabled/Disabled	
	<i>no00</i>	Disabled
	<i>YE40</i>	Enabled

13.8 Engineering Mode 2

The PV Display (upper row) indicates setting characters, and the SV Display (lower row) indicates factory default value.

Characters, Factory Default	Setting Item, Setting Range	
<i>co4L</i> <i>noñL</i>	Control method	
	<i>noñL</i>	PID control
	<i>2boF</i>	2DOF PID control
<i>tPRH</i> 0.40	Proportional gain 2DOF coefficient (α) 0.00 to 1.00	
<i>P1 bF</i> 0.135	Integral 2DOF coefficient (β) 0.00 to 10.00	

14. Key Operation Flowchart

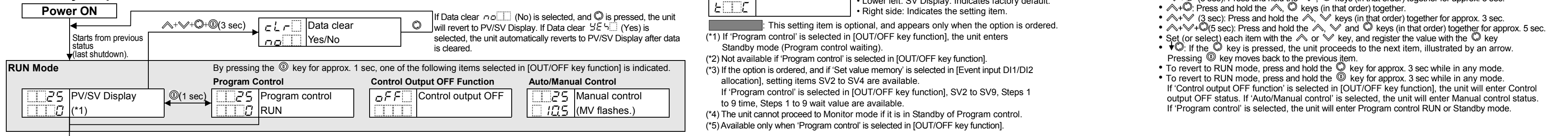

About Setting Item

- Upper left: PV Display: Indicates setting characters.
- Lower left: SV Display: Indicates factory default.
- Right side: Indicates the setting item.
- This setting item is optional, and appears only when the option is ordered.
- (*)1 If 'Program control' is selected in [OUT/OFF key function], the unit enters Standby mode (Program control waiting).
- (*)2 Not available if 'Program control' is selected in [OUT/OFF key function].
- (*)3 If the option is ordered, and if 'Set value memory' is selected in [Event input DI1/DI2 allocation], setting items SV2 to SV9 are available. If 'Program control' is selected in [OUT/OFF key function], SV2 to SV9, Steps 1 to 9 wait value are available.
- (*)4 The unit cannot proceed to Monitor mode if it is in Standby of Program control.
- (*)5 Available only when 'Program control' is selected in [OUT/OFF key function].

Key Operation

- Press and hold the \wedge , \vee , \odot (3 sec): Press and hold the \wedge , \vee , \odot keys (in that order) together for approx. 3 sec.
- Press and hold the \wedge , \vee (3 sec): Press and hold the \wedge , \vee keys (in that order) together for approx. 3 sec.
- Press and hold the \wedge , \odot (3 sec): Press and hold the \wedge , \odot keys (in that order) together for approx. 3 sec.
- Press and hold the \vee , \odot (3 sec): Press and hold the \vee , \odot keys (in that order) together for approx. 3 sec.
- Press and hold the \wedge , \vee , \odot (5 sec): Press and hold the \wedge , \vee , \odot keys (in that order) together for approx. 5 sec.
- Set (or select) each item with the \wedge or \vee key, and register the value with the \odot key.
- If the \odot key is pressed, the unit proceeds to the next item, illustrated by an arrow. Pressing \odot key moves back to the previous item.
- To revert to RUN mode, press and hold the \odot key for approx. 3 sec while in any mode.
- To revert to RUN mode, press and hold the \odot key for approx. 3 sec while in any mode. If 'Control output OFF function' is selected in [OUT/OFF key function], the unit will enter Control output OFF status. If 'Auto/Manual control' is selected, the unit will enter Manual control status. If 'Program control' is selected, the unit will enter Program control RUN or Standby mode.

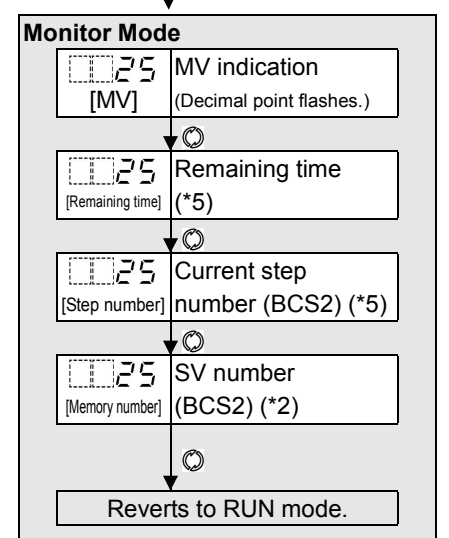
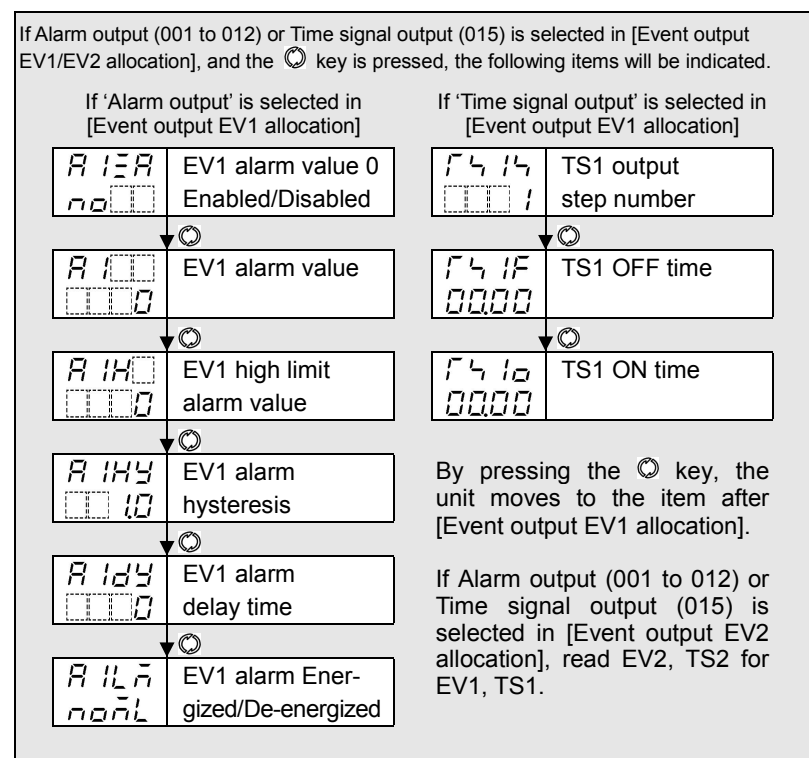
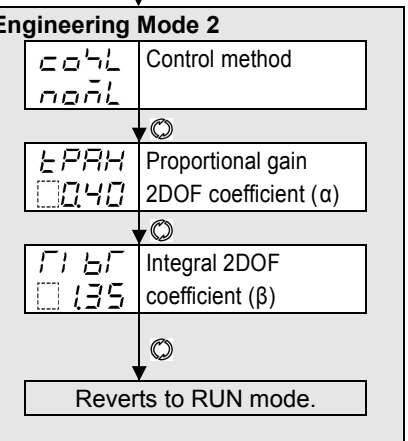
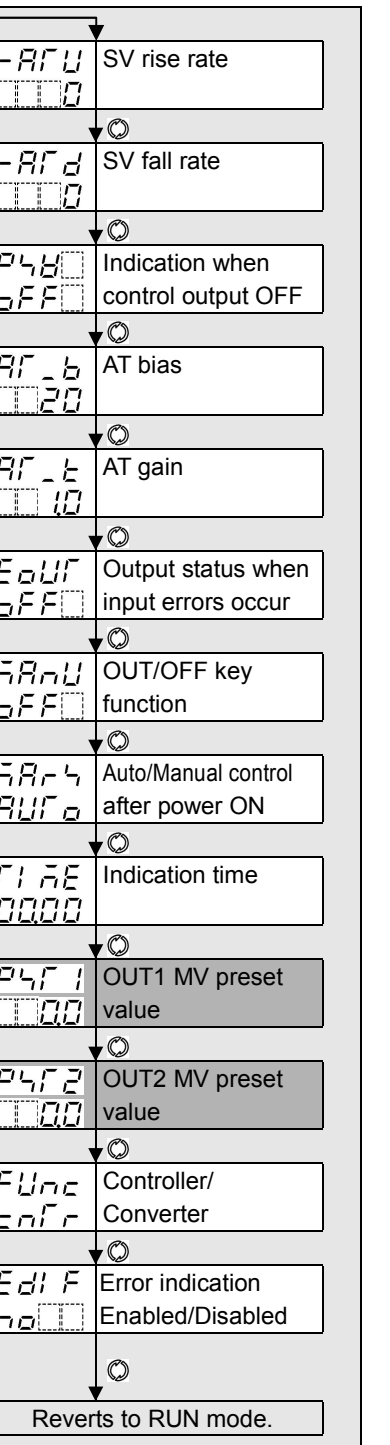
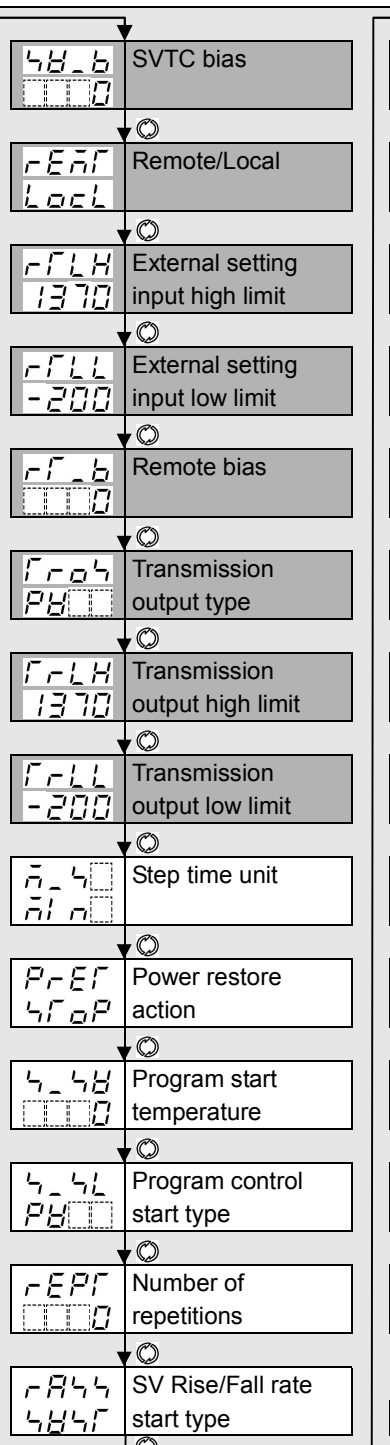
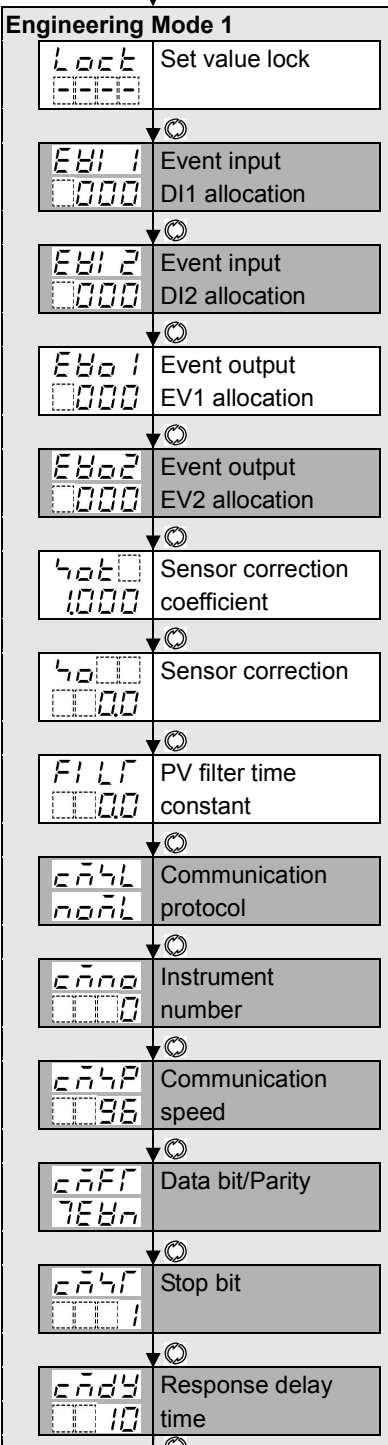
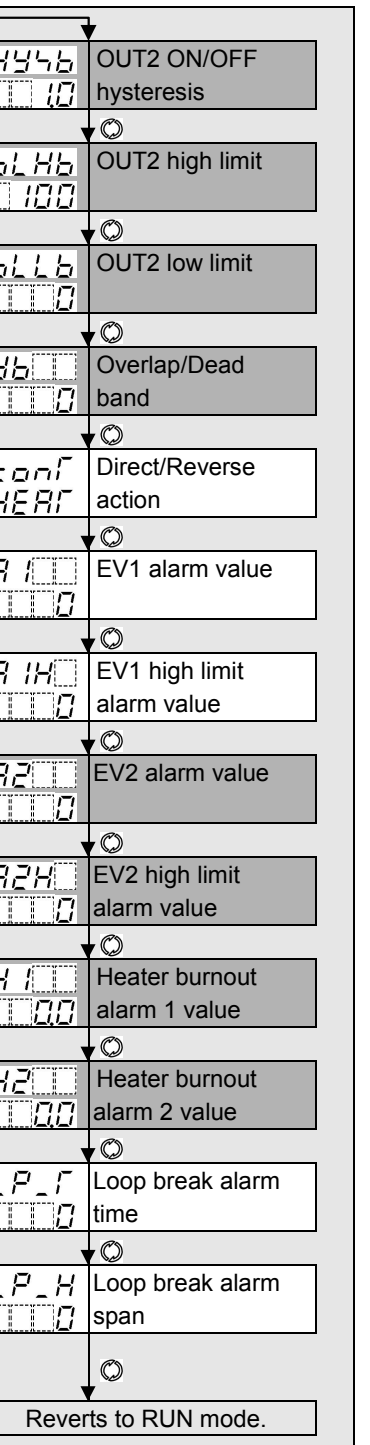
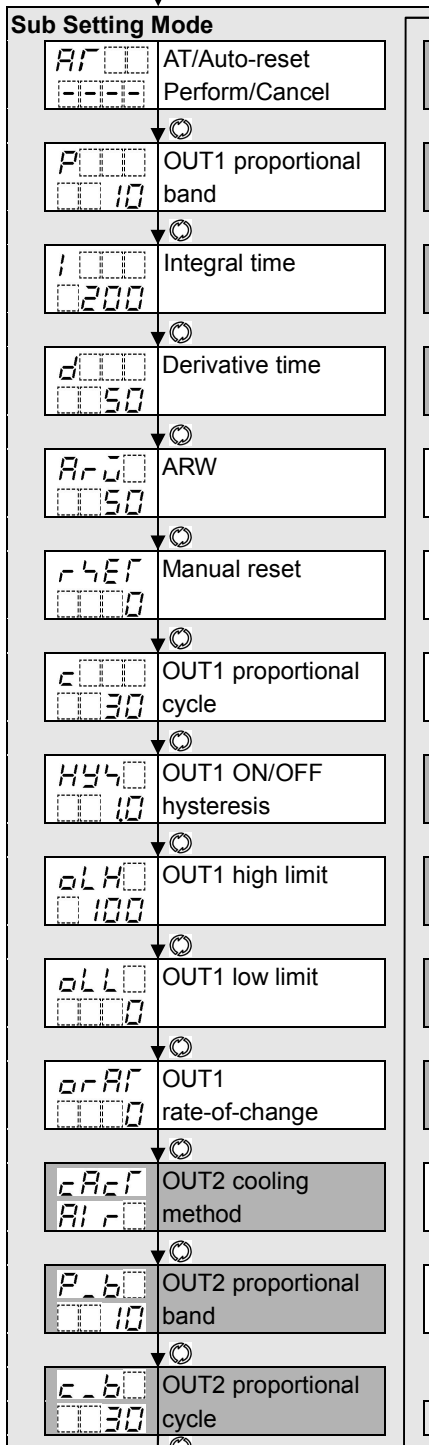
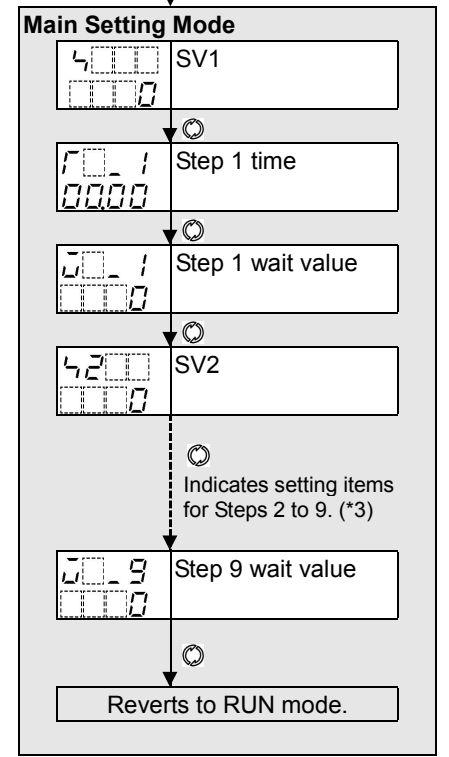
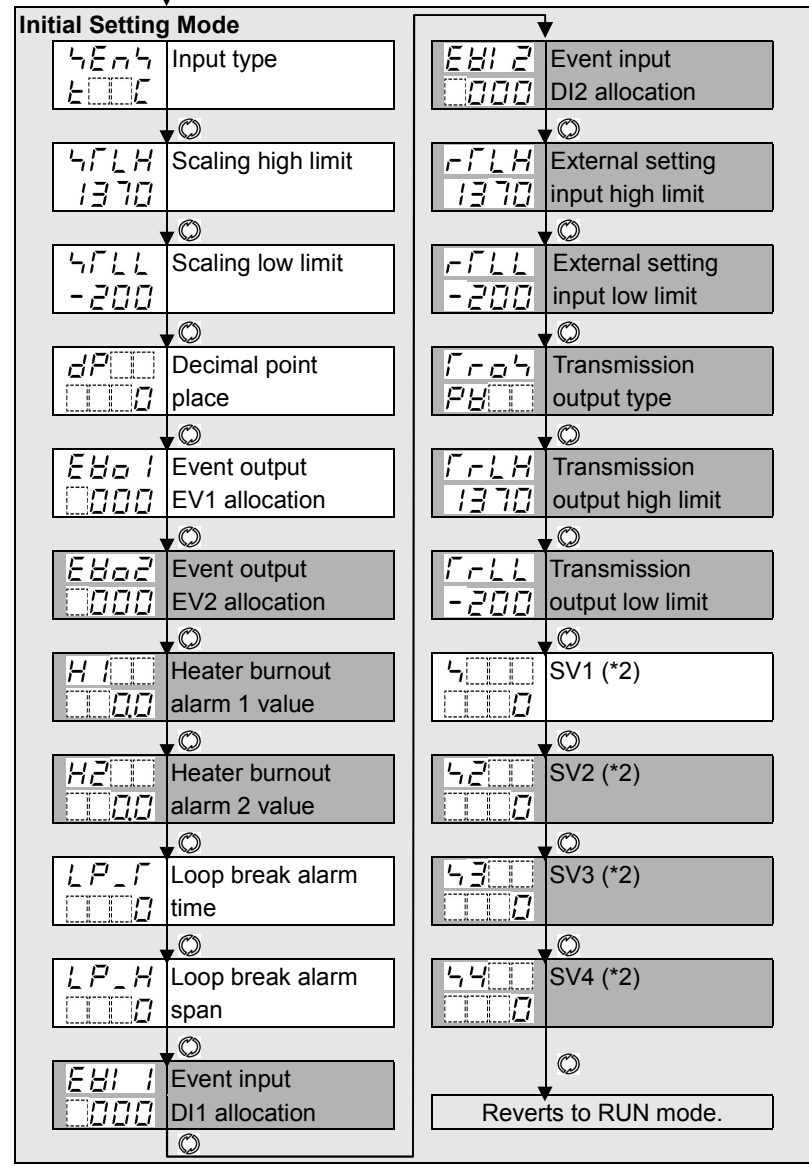

Input type	r f . f T -328.0 to 752.0 F	0003 H/L limits alarm	n o Disabled	P y PV transmission	0012 2 bits	P y R L PV + Any Alarm active
e . c K -200 to 1370 °C	n . f N -328 to 2372 F	0004 H/L limits independent	y e 4 Enabled	y b SV transmission	Remote/Local	P y R L PV + Any Alarm active
e . c K -200.0 to 400.0 °C	P L 2 F PL-II 32 to 2534 F	0005 H/L limit range alarm	EV1/EV2 alarm	n b MV transmission	L o c L Local	Output status when input errors occur
J . c J -200 to 1000 °C	c . f C(W/Re5-26) 32 to 4199 F	0006 H/L limit range independent	Energized/De-energized	d b DV transmission	r e R Remote	o f f Output OFF
r . c R 0 to 1760 °C	P r . f Pt100 -328.0 to 1562.0 F	0007 Process high alarm	n o n L Energized	AT/Auto-reset Perform/Cancel	Step time unit	o n Output ON
s . c S 0 to 1760 °C	J P F JPt100 -328.0 to 932.0 F	0008 Process low alarm	r e 4 De-energized	AT/Auto-reset Cancel	n i n Hours:Minutes	o f f Control output OFF
b . c B 0 to 1820 °C	P r . f Pt100 -328 to 1562 F	0009 High limit with standby	Event input DI1/DI2 allocation	R f AT Perform	y e c Minutes:Seconds	o f f Control output OFF
e . c E -200 to 800 °C	J P F JPt100 -328 to 932 F	0010 Low limit with standby	0000 No event	R f 4 AT on startup Perform	Power restore action	n R n Auto/Manual control
r . c T -200.0 to 400.0 °C	4 2 0 R 4 to 20 mA -2000 to 10000	0011 H/L limits with standby	0001 Set value memory	r 4 E Auto-reset Perform	P r o Program control	P r o Program control
n . c N -200 to 1300 °C	0 2 0 R 0 to 20 mA -2000 to 10000	0012 H/L limits with standby independent	0002 Control ON/OFF	OUT2 cooling method	c o n Continue (resume)	Auto/Manual control after power ON
P L 2 C PL-II 0 to 1390 °C	0 1 B 0 to 1 V -2000 to 10000	0013 Heater burnout alarm output	0003 Direct/Reverse action	R i r Air cooling	H o l d Suspend (on hold)	R u f o Automatic control
c . c C(W/Re5-26) 0 to 2315 °C	0 1 S 0 to 5 V -2000 to 10000	0014 Loop break alarm output	0004 Preset output 1 ON/OFF	o i L Oil cooling	Program control start type	n R n Manual control
P t 1 0 0 Pt100 -200.0 to 850.0 °C	1 1 S 0 1 to 5 V -2000 to 10000	0015 Time signal output	0005 Preset output 2 ON/OFF	W a r Water cooling	0 1 9 2 19200 bps	Controller/Converter function
J P F C JPt100 -200.0 to 500.0 °C	0 1 0 B 0 to 10 V -2000 to 10000	0016 Output during AT	0006 Auto/Manual control	Direct/Reverse action	3 8 4 0 38400 bps	c n r Controller
P r . f Pt100 -200 to 850 °C	Decimal point place	0017 Pattern end output	0007 Remote/Local	H e R Reverse action	Data bit/Parity	c n r Converter
J P F C JPt100 -200 to 500 °C	0000 No decimal point	0018 Output by communication command	0008 Program control Run/Stop	c o a L Direct action	8 n o n 8 bits/No parity	c n r Converter
e . c K -328 to 2498 F	0001 1 digit after decimal point	0019 Heating/Cooling control relay contact output (for EV2 only)	0009 Program control Holding/Not holding	Set value lock	7 n o n 7 bits/No parity	o n Error indication Enabled/Disabled
e . c K -328.0 to 752.0 F	0002 2 digits after decimal point	EV1/EV2 alarm value 0	0010 Program control Advance function	L o c 1 Lock 1	8 e e n 8 bits/Even	n o Disabled
J . c J -328 to 1832 F	0003 3 digits after decimal point	Disabled/Enabled	0011 Integral action Holding	L o c 2 Lock 2	7 e e n 7 bits/Even	y e 4 Enabled
r . c R 32 to 3200 F	0004 No event	Transmission output	0012 Program control	L o c 3 Lock 3	8 o d d 8 bits/Odd	Control method
s . c S 32 to 3200 F	0005 High limit alarm		0013 Program control	L o c 4 Lock 4	7 o d d 7 bits/Odd	o f f OFF indication
b . c B 32 to 3308 F	0006 Low limit alarm		0014 Program control	L o c 5 Lock 5	Stop bit	R o f f No indication
e . c E -328 to 1472 F			0015 Program control		1 bit	P y PV indication
			0016 Program control			
			0017 Program control			
			0018 Program control			
			0019 Program control			

***** Inquiries *****

For any inquiries about this unit, please contact our agency or the vendor where you purchased the unit after checking the following.

[Example]

- Model ----- BCS2R00-12
- Option ----- EV2, C5W (100A)
- Serial number ----- No. 145F05000

In addition to the above, please let us know the details of the malfunction, or discrepancy, and the operating conditions.

MOD-TRONIC

www.mod-tronic.com | sales@mod-tronic.com | 1-800-794-5883