

Ranges and Resolution

See table below. Select range and default engineering units. Consult factory for special engineering units. Units may be changed to any listed under the same sensor range. Resolution is fixed and limited to available display digits.

Accuracy

Accuracy includes linearity, hysteresis, repeatability
Standard accuracy: ±0.25% of full scale ±1 least significant digit
HA accuracy option: ±0.1% FS ±1 LSD, see ranges for availability
Sensor hysteresis: ±0.015% FS, included in accuracy
Sensor repeatability: ±0.01% FS, included in accuracy

Display

3 readings per second nominal display update rate
4 digit LCD, 0.5" H and 5 character 0.25" H alphanumeric

BL: Red LED backlight

Batteries, Battery Life, Low Battery Indication

2 AA alkaline included
B: Approx. 2000 hours
BL: Approx. 150-1500 hours depending on backlight usage
Low battery symbol on display

Controls & Functions

Front button turns gauge on or off, zeros gauge reference gauges, and cycles through min./max. functions
Internal buttons for engineering unit selection, auto shutoff time, min/max setup, calibration. Pass code protected setup & calibration.

BL: Front button activates backlighting for 1 minute

Min./Max. Functions

Minimum and maximum readings stored 3 times per second
Front button cycles through min. display, max. display, clear
Configurable for min. only, max. only, min./max., or none
Configure to clear or retain min./max. values at power off

Calibration

Pass code protected calibration
Non-interactive zero, span, and linearity, ±10% of range

Auto Shutoff

User selectable 1 minute to 8 hours or front button on/off
Factory default 5 minutes, unless other time is specified

Weight

Gauge: 9 ounces, shipping: 1 pound (approximately)

Housing

F16B: Extruded aluminum case, epoxy powder coated, ABS/polycarbonate bezel (aluminum bezel optional), front and rear gaskets, polycarbonate label

F16BN: ABS/polycarbonate NEMA 4X case, rear gasket, polycarbonate label

Connection and Material

1/4" NPT male fitting, all wetted parts are 316L stainless steel

Overpressure, Burst, Vacuum

Ranges using 3000 psig sensor: 5000 psig
Ranges using 5000 psig sensor: 7500 psig
All others: 2 X pressure range
3000 psi, 5000 psi, and 4 digit ranges 112.5% full scale out-of-range display: 1--- or 1-.-.-
4 X sensor burst pressure rating, or 10,000 psi, whichever is less
Vacuum service: 15 psia, ±15 psig, 15 psig, 30 psia, 100 psig, 100 psia, 200 psig sensors

Under-range display (non-vacuum sensors): -Err

Environmental

Storage temperature: -40 to 203°F (-40 to 95°C)
Operating temperature: -4 to 185°F (-20 to 85°C)
Compensated temperature: 32 to 158°F (0 to 70°C)

- ±0.25% Test Gauge Accuracy
- 316L Stainless Steel Wetted Parts
- User Configurable Min/Max, Units, Shutoff Time



F16B



F16BN
NEMA 4X



Sensor Ranges and Engineering Units		* -HA option not available		Range codes are rounded off	
3 psig *	Res	15 psig vac *	Res	30 psia	Res
3PSIG	.001	100KPAVAC	.001	2KGCMA	.001
6INHGG	.001	0.1MPAVAC	.0001	2ATMA	.001
85INH20G	.1	1BARVAC	.001	30 psig	Res
50ZING	.01	1KGCMVAC	.001	30PSIG	.01
210GCMG	.1	1ATMVAC	.001	60INHGG	.01
150MMHGG	.1	15 psig	Res	850INH20G	1
150TORRRG	.1	15PSIG	.01	480ZING	.1
200MBARG	.1	30INHGG	.01	2100GCMG	1
200CMH20G	.1	400INH20G	.1	1600MMHGG	1
2000MMH20G	.1	240ZING	.1	1600TORRRG	1
7FTH20	.001	1000GCMG	1	2000MBARG	1
20KPAG	.01	760MMHGG	.1	2100CMH20G	1
5 psig *	Res	760TORRRG	.1	70FTH20	.01
5PSIG	.001	1000MBARG	1	200KPAG	.1
10INHGG	.01	1000CMH20G	1	0.2MPAG	.0001
140INH20G	.1	35FTH20	.01	2BARG	.001
80ZING	.1	100KPAG	.1	2KGCMG	.001
350GCMG	.1	0.1MPAG	.0001	2ATMG	.001
260MMHGG	.1	1BARG	.001	60 psig	Res
260TORRRG	.1	1KGCMG	.001	60PSIG	.01
350MBARG	.1	1ATMG	.001	120INHGG	.1
350CMH20G	.1	±15 psig *	Res	1660INH20G	1
3500MMH20G	.1	±15PSIG	.01	960ZING	1
12FTH20	.01	-30INHGG/15PSIG	.01	4200GCMG	1
35KPAG	.01	±30INHGG	.01	3100MMHGG	1
15 psia	Res	±400INH20G	1	3100TORRRG	1
15PSIA	.01	±240ZING	.1	4100MBARG	1
30INHGA	.01	±1000GCMG	1	4200CMH20G	1
400INH20A	.1	±760MMHG	1	140FTH20	.1
240ZINA	.1	±760TORRRG	1	400KPAG	.1
1000GCMG	1	±1000MBARG	1	0.4MPAG	.0001
760MMHGA	.1	±1000CMH20G	1	4BARG	.001
760TORRRA	.1	±100KPAG	.1	4KGCMG	.001
1000MBARA	1	±0.1MPAG	.0001	4ATMG	.001
1000CMH20A	1	±1BARG	.001	100 psia	Res
100KPAA	.1	±1KGCMG	.001	100PSIA	.1
0.1MPAA	.0001	±1ATMG	.001	200INHGA	.1
1BARA	.001	30 psia	Res	2770INH20A	1
1KGCMG	.001	30PSIA	.01	1600ZINA	1
1ATMA	.001	60INHGA	.01	7000GCMG	1
15 psig vac *	Res	850INH20A	1	5200MMHGA	1
15PSIVAC	.01	480ZINA	.1	5200TORRRG	1
30INHGVAC	.01	2100GCMG	1	7000MBARA	1
400INH20VAC	.1	1600MMHGA	1	7000CMH20A	1
240ZINVAC	.1	1600TORRRG	1	700KPAA	.1
1000GCMVAC	1	2000MBARA	1	0.7MPAA	.0001
760MMHGVAC	.1	2100CMH20A	1	7BARA	.001
760TORRRVAC	.1	200KPAA	.1	7KGCMA	.001
1000MBARVAC	1	0.2MPAA	.0001	7ATMA	.001
1000CMH20VAC	1	2BARA	.001	14ATMG	.01

How to Specify	Type
F16B range - time - options	Standard housing
F16BBL range - time - options	Std. housing, backlit display
F16BN range - time - options	NEMA 4X housing
F16BNBL range - time - options	NEMA 4X, backlit display

Range—See table at left. Select a range code for default units. Please specify if vacuum gauge requires a minus sign.

psi = PSI torr = TORR mbar = MBAR
inHg = INHG mmH2O = MMH2O bar = BAR
oz/in² = ZIN kg/cm² = KGCM cmH2O = CMH2O
inH2O = INH2O g/cm² = GCM atm = ATM
ftH2O = FTH2O kPa = KPA
mmHg = MMHG MPa = MPA

G gauge reference pressure VAC gauge reference vacuum
CPD inHg vac / psig pressure A absolute reference

Time	auto shutoff time.
5	5 minutes. Default if not specified.
10	10 minutes
30	30 minutes
ON	No auto shutoff. On/off via front button.

Options	add to end of model number. See price list for details.
HA	High accuracy, ±0.1% FS ±1 LSD. See range table.
PM	Panel mount, 4.1" x 4.1", n/a NEMA 4X
FP	Sealed housing and CC for high humidity food processing applications. F16BN in absolute ref. ranges only.
MC	Metal front cover instead of plastic, n/a NEMA 4X
CS	Case bottom stiffener plate, n/a NEMA 4X
CC	Moisture resistant circuit board conformal coating
TP	Top port, gauge port on top of case, n/a NEMA 4X
SM	Surface mount plate, n/a NEMA 4X
CD	Calibration data; 5 test points and date
NC	NIST traceability documentation, 5 points and date

TP
Top gauge port. Primarily used with tire pressure applications. Not available with NEMA 4X models.

Accessories—order separately

RB
High visibility orange rubber boot protects gauge for portable applications. Not for NEMA 4X models.

SCR14SS
Filter screen fitting keeps debris out of gauge sensor. For food vacuum packaging applications. 303SS body, 100 micron 304SS screen.

CON14SS
Quick connector to install or remove gauge without tools. 304 stainless steel, urethane seal.



Dimensions

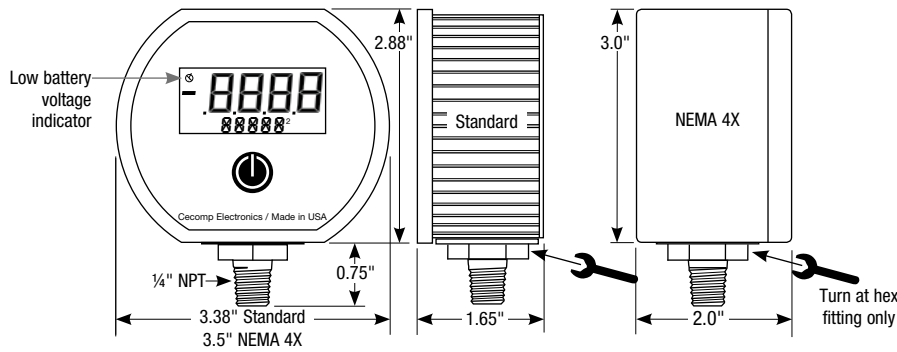

Installation Precautions

- ✓ Read these instructions before using the gauge. Configuration may be easier before installation. Contact the factory for assistance.
- ✓ These products do not contain user-serviceable parts. Contact us for repairs, service, or refurbishment.
- ✓ Gauges must be operated within specified ambient temperature ranges.
- ✓ Outdoor or wash down applications require a NEMA 4X gauge or installation in a NEMA 4X housing.
- ✓ Use a pressure or vacuum range appropriate for the application.
- ✓ Use fittings appropriate for the pressure range of the gauge.
- ✓ Due to the hardness of 316 stainless steel, it is recommended that a thread sealant be used to ensure leak-free operation.
- ✓ For contaminated media use an appropriate screen or filter to keep debris out of gauge port.
- ✓ Remove system pressures before removing or installing gauge.
- ✓ Install or remove gauge using a wrench on the hex fitting only. Do not attempt to turn gauge by forcing the housing.
- ✓ Good design practice dictates that positive displacement liquid pumps include protection devices to prevent sensor damage from pressure spikes, acceleration head, and vacuum extremes.
- ✗ Avoid permanent sensor damage! Do not apply vacuum to non-vacuum gauges or hydraulic vacuum to any gauges.
- ✗ Avoid permanent sensor damage! NEVER insert objects into gauge port or blow out with compressed air.
- ⚠ Gauges are not for oxygen service. Accidental rupture of sensor diaphragm may cause silicone oil inside sensor to react with oxygen.

Cecomp maintains a constant effort to upgrade and improve its products. Specifications are subject to change without notice. See cecomp.com for latest product information. Consult factory for your specific requirements.

 **WARNING:** This product can expose you to chemicals including nickel and chromium, which are known to the State of California to cause cancer or birth defects or other reproductive harm. For more information go to www.P65Warnings.ca.gov

Types of Gauges

Bipolar ranges read positive pressure and vacuum in the same units, and zero with the gauge port open.

1000 psi and higher sensor are a sealed reference type. They read zero with the gauge port open are internally referenced to 14.7 psi. Functionally similar to gauge reference sensors.

Absolute reference gauges read zero at full vacuum and atmospheric pressure with the gauge port open. With an open gauge port the readings will vary continuously due to the effects of barometric pressure.

Selectable Ranges

Range Codes

The range code is part of the gauge model number and indicates the default range when the gauge is ordered.

Selectable Ranges

Engineering units may be changed to any of those listed in the same sensor range as shown in the range table.

Conversion

Engineering units are calculated from the factory default unit to the newly selected units. The ranges listed under the psi sensor range are rounded off.

Operation

Power-Up

Press and hold the front button for approximately 1 second.

The display is tested, the default full-scale range is indicated, the full-scale range in the selected units are indicated, the display is tested again, then the actual pressure and units are displayed.

Power-Up With Zero

This applies to gauge reference models only. Absolute reference gauges do not use the zero feature since they read atmospheric pressure under normal conditions.

Be sure the gauge port is exposed to normal atmospheric pressure and no pressure is applied. The zeroing function is only activated at each power-up and the stored zero correction is erased when the gauge is shut off.

Press and hold the front button. The display is tested and then 0000 is displayed. The gauge is now zeroed. Release the button and the full-scale range in the selected units are indicated, the display is tested again, then the actual pressure and units are displayed.

Attempting to zero the gauge with pressure greater than approximately 3% of full-scale pressure or vacuum applied will result in an error condition, and the display will alternately indicate Err 0 and the actual measured pressure. The gauge must be powered down to reset the error condition.

Normal Operation

Following the start-up initialization, the display indicates the pressure reading updated approximately 3 times per second. The auto shutoff timer starts when the gauge is powered up or whenever the button is pushed, unless the gauge shutoff time was set to zero for on/off operation.

If excessive vacuum is applied to a pressure-only gauge, the display will indicate -Err until the vacuum is released. Applying vacuum to a gauge designed for pressure may damage the pressure sensor.

If excessive pressure is applied (112.5% over range), an out-of-range indication of 1--- or 1.-- will be displayed depending on model.

Display Backlighting (BL models only)

Display backlighting can be turned on by momentarily pressing the front button whenever the gauge is on. The backlighting will turn on for one minute and then automatically shut off. This also restarts the auto shutoff timer. The display backlighting will not be apparent under bright lighting conditions.

Minimum and Maximum Readings

Gauges are normally configured with minimum and maximum capture functions enabled. One or both can be disabled in the Advanced Configuration mode.

Minimum and maximum readings are continuously stored and updated whenever the gauge is on. The stored readings can be manually cleared if desired. The MAX and MIN memory is also cleared whenever the gauge is off unless configured to save the readings.

Press and hold the button for about 1 second until MAX is displayed alternating with the units. The maximum reading will be continuously updated. The gauge may be left in this mode.

After MAX is displayed, press and hold the button for about 1 second until MIN is displayed alternating with the units. The minimum reading will be continuously updated. The gauge may be left in this mode. If excessive vacuum is applied to a pressure-only gauge while in this mode, the display will indicate -Err until the MAX/MIN readings are cleared.

After MIN is displayed, press and hold the button again for about 1 second until *** is displayed. The MAX and MIN memory is not erased and the gauge returns to normal operation with the display indicating the current reading.

Operation—continued

Press and continue to hold the button until the display indicates CLR MX/MIN (about 3 seconds total) and then release the button. Both maximum and minimum values are cleared and the gauge returns to the normal mode and displays the current pressure.

Shut-Down

To shut off the gauge manually at any time, press and hold the button until the display indicates OFF (about 5 seconds) and then release.

When an auto shutoff timer is used, the display indicates OFF five seconds prior to auto shutoff. The button can be pressed to keep the gauge on. The auto shutoff and backlight (if equipped) timers are reset whenever the button is pressed and released.

If the gauge is set up without auto shutoff (on/off operation) it will stay on until manually shut off or until the batteries are depleted. Turn gauge off when not in use to conserve battery life.

Function	Button	Prompt (Release Button)
On	Press for 1 second	Display test > default units > selected units FULL SCALE > display test > actual reading
Zero (gauge ref. only)	Press and hold	Display test > 0000 > default units > selected units FULL SCALE > display test > actual reading
Hi reading	Press/hold	MAX > max. reading & units
Lo reading	Press/hold	MIN > min. reading & units
Exit Hi/Lo	Press/hold	**** > actual reading
Clear Hi/Lo	Press/hold	MAX > CLR MAX/MIN > actual reading
Clear, off	Press/hold	MAX > CLR MAX/MIN > OFF

Basic Configuration

Accessing the Internal Buttons

1. Remove the 6 Phillips screws on the back of the unit.
2. Lift up the battery holder.
3. Move the battery holder to the side.
4. For gauges with the standard metal housing, remove the battery cradle if necessary to gain access to the two internal buttons located near the lower right and left corners of the circuit board.

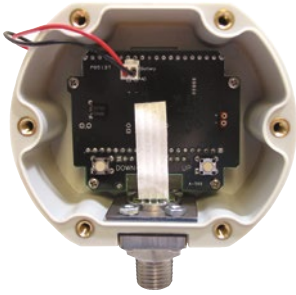

Auto Shutoff Time Selection

Auto shutoff time selection is done via the internal buttons to help prevent accidental or unauthorized changes. The selected shut off time is stored in non-volatile memory and will be retained even with the battery off or batteries removed.

Remove the rear cover to gain access to the two internal buttons located near the lower right and left corners of the circuit board.

With the gauge powered up, press and hold the DOWN button.

Release the button when the auto shutoff time is displayed on the upper display.

The lower display will indicate AST M if the time displayed is in minutes, and AST H if it in hours.

An auto shutoff time of 0 signifies that the auto shutoff feature is disabled and the front button turns the gauge on and off.

Use the UP and DOWN buttons to select 0, 1, 2, 5, 10, 15, 20 or 30 minutes, or 1, 2, 4, or 8 hours.

When the desired time is displayed, press and release the front button to save the selection and return to normal operation.

Note: The gauge will automatically revert to normal operation if no buttons are operated for approximately 15 seconds.

Replace the battery holder assembly and rear cover taking care not to pinch the power wires between the cover and the case.

Engineering Unit Selection

Engineering unit selection (except compound ranges) is done via internal buttons to help prevent accidental or unauthorized changes. The selected engineering unit is stored in non-volatile memory and will be retained even with the gauge off or batteries removed. The available engineering units depend on the sensor range and display resolution.

Compound (inHg/PSIG) gauges must be changed to display single-unit vacuum/pressure readings in the Advanced Configuration mode before different engineering units can be selected.

The default engineering units are mathematically converted to the newly selected engineering unit. When the gauge is powered up, the originally configured range is displayed and then the conversion with the selected engineering unit is displayed.

Powered the gauge up by holding the front button for 1 second.

Press and hold the internal UP button.

Release the button when the engineering units begin to flash.

Use the UP and DOWN buttons to scroll through the list of engineering units available for the pressure range of the sensor.

When the desired units are displayed, press and release the front button to save the selection and return to normal operation.

Note: The gauge will automatically revert to normal operation if no buttons are operated for approximately 15 seconds.

Replace the battery holder assembly and rear cover taking care not to pinch the power wires between the cover and the case.

Advanced Configuration

Advanced configuration requires a pass code for access and allows more features to be configured.

Remove the rear cover to gain access to the buttons located near the lower right and left corners of the circuit board.

With the gauge off, press and hold the UP button. Then press the front button. Release all buttons when the display indicates CFG and the program version then the full-scale range is indicated and the display is tested.

The display then indicates _ _ _ _ with the first underscore blinking, and with CFGPC (configuration pass code) on the character segments.

Note: The gauge will automatically revert to normal operation if no buttons are operated for approximately 15 seconds. To cancel and return to normal operation, press and release the front button without entering any pass code characters.

Pass Code Entry

The factory default is 3510, but this may be changed by the user under the Pass Code Configuration section.

1. Use the UP or DOWN buttons to set the left-most digit to 3.
2. Press and release the front button to move to the next position. The 3 will remain, and the second position will be blinking.
3. Use the UP or DOWN buttons to select 5.
4. Press and release the front button to index to the next position. 35 will remain, and the third position will be blinking.
5. Use the UP or DOWN buttons to select 1.
6. Press and release the front button to index to the next position. 351 will remain, and the fourth position will be blinking.
7. Use the UP or DOWN buttons to select 0.
8. Press and release the front button to proceed with configuration procedures.

If an incorrect pass code is entered, the gauge will return to the start of the pass code entry sequence.

Factory/User Configuration

The upper display section will be blank, and the lower section will display either USER_ or FCTRY.

If USER_ is selected, the user configuration can be modified as described in the following steps.

To select USER_, press and release the DOWN button.

The lower display will indicate USER_.

Press and release the front button to continue.

If FCTRY is selected, the existing user configuration will be replaced by the original factory configuration.

To select FCTRY, press and release the UP button.

The lower display will indicate FCTRY.

Press and release the front button to restore the factory configuration and restart the gauge.

Max/Min Configuration

Use the UP and DOWN buttons to select from the following:

- MX/MN Both highest and lowest values will be captured
- MX/--- Only highest value will be captured
- /MN Only lowest value will be captured
- /-- Capture feature is disabled

Press and release the front button to move to the next parameter.

Max/Min Memory

The upper display section will indicate clr.

Use the UP and DOWN buttons to select from the following:

- AUTO Automatically clear max. and min. values when the gauge is powered off
 - MAN Manually clear max. and min. values
- Press and release the front button to move to the next parameter.

Gauge Type Configuration

This will only appear with 15, 100, or 200 psig ranges that were originally ordered as compound gauges.

Use the UP and DOWN buttons to select from the following:

- /+EU Vacuum is indicated as negative pressure in the selected engineering units
- CMPND Vacuum is negative INHG, pressure is PSIG. This setting will disable engineering unit selection.

Press and release the front button to save the user configuration and restart the gauge.

Replace the rear cover taking care not to pinch the power wires between the cover and the case.

Battery Replacement

A low battery indication will be shown in the upper left-hand corner of the display when the battery voltage falls sufficiently. The batteries should be replaced soon after the indicator comes on or unreliable readings may result. 

1. Remove the 6 Phillips screws on the back of the unit.
2. Lift up the battery holder.
3. Remove batteries by lifting up the positive end of the battery (opposite the spring) taking care not to bend the battery holder spring.
4. Discard old batteries properly, do not discard into fire, sources of extreme heat, or in any hazardous manner.
5. Always replace both batteries at the same time with high quality alkaline batteries.
6. Install batteries with correct orientation. Incorrect polarity will damage the gauge. The negative (flat) end of each battery should be inserted first facing the battery holder spring.
7. Replace battery holder and back cover, including the rubber gasket and reinstall the six screws.



Calibration Preparation

Gauges are calibrated at the factory using equipment traceable to NIST. There is no need to calibrate the gauge before putting it into service. Calibration intervals depend on your quality control program requirements, although many customers calibrate annually. Calibration should only be performed by qualified individuals using appropriate calibration standards and procedures. The calibration equipment should be at least four times more accurate than the gauge being calibrated.

The calibration system must be able to generate and measure pressure/vacuum over the full range of the gauge.

A vacuum pump able to produce a vacuum of 100 microns (0.1 torr or 100 millitorr) or lower is required for vacuum and absolute gauges.

Warning: application of vacuum to non-vacuum models may result in irreparable damage to the sensor.

Allow the gauge to acclimate to ambient temperature for 20 minutes.

Remove the rear cover to gain access to the UP and DOWN buttons located near the lower right and left corners of the circuit board.

Install fresh batteries.

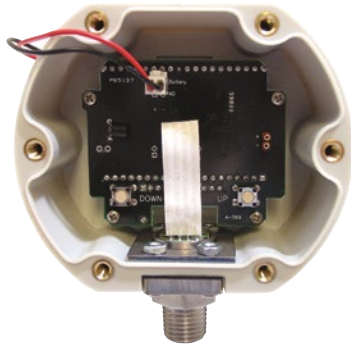

Calibration

Entering Calibration Mode

With the gauge off, press and hold the DOWN button. Then press the front button. Release all buttons when the display indicates CAL. The display begins by indicating the full-scale positive pressure rating of the gauge in the engineering units as configured by the factory, and then shows all display.

Before the gauge enters the Calibration Mode, the display initially indicates ____ with the first underscore blinking, and with CALPC (calibration pass code) on the lower display.

Note: The gauge will automatically revert to normal operation if no buttons are operated for approximately 15 seconds. To cancel and return to normal operation, press and release the front button without entering any pass code characters.

Enter the User-Modifiable Pass Code

The factory default is 3510, but this is user changeable.

1. Use the UP or DOWN buttons to set the left-most digit to 3.
2. Press and release the front button to move to the next position. The 3 will remain, and the second position will be blinking.
3. Use the UP or DOWN buttons to select 5.
4. Press and release the front button to index to the next position. 35 will remain, and the third position will be blinking.
5. Use the UP or DOWN buttons to select 1.
6. Press and release the front button to index to the next position. 351 will remain, and the fourth position will be blinking.
7. Use the UP or DOWN buttons to select 0.
8. Press and release the front button to proceed with configuration procedures.

If an incorrect pass code is entered, the gauge will return to the start of the pass code entry sequence.

Calibration Mode

The gauge enters and remains in the calibration mode until restarted manually or power is removed. Features not related to calibration are disabled and compound range models are set for the same engineering units for pressure and for vacuum.

The calibration may be performed in any of the available engineering units as well as percent (PCT). For greatest accuracy, use the UP and DOWN buttons to select engineering units for calibration with highest resolution (highest number of display counts). Press and

Calibration—continued

release the front button when the appropriate engineering units are displayed. Suggested units are listed below.

Sensor	Suggested units for calibration
5 PSI	5.000 PSI
15 PSI	775.7 MMHG (TORR)
30 PSI	61.08 INHG
50 PSI	50.00 PSI
60 PSI	60.00 PSI
100 PSI	7.031 KG/CM2
200 PSI	407.2 INHG
300 PSI	610.8 INHG
500 PSI	500.0 PSI
1000 PSI	70.31 KG/CM2
2000 PSI	4072 INHG
3000 PSI	6108 INHG
5000 PSI	5000 PSI
Any	100.00 PCT (percent)

The display will then indicate the currently applied pressure in the engineering units selected for calibration.

UP and DOWN Button Operation

Each time one of the calibration buttons is pressed and released quickly, a small change is made to the digitized pressure signal. It may take more than one of these small changes to result in a single digit change on the display.

To make larger changes, press and hold the appropriate calibration button. After about one second, the display will begin to change continuously. Release the button to stop. Then make fine adjustments by pressing and quickly releasing the calibration buttons as previously described.

Gauge Reference Pressure Gauges

Apply zero pressure by venting the gauge port to atmosphere. The character display will alternate between ZERO and CAL. Adjust for a display indication of zero using the UP and the DOWN buttons.

Apply full-scale pressure. The character display will alternate between +SPAN and CAL. Adjust for a display indication of full-scale pressure using the UP and the DOWN buttons.

Apply 50% full-scale pressure. The character display will alternate between +MID and CAL. Adjust for a display indication equal to 50% of full-scale pressure using the UP and the DOWN buttons.

Gauge Reference Vacuum Gauges

Apply zero pressure by venting the gauge port to atmosphere. The character display will alternate between ZERO and CAL. Adjust for a display indication of zero using the UP and the DOWN buttons.

Apply full-scale vacuum. The character display will alternate between +SPAN and CAL. Adjust for a display indication of full-scale vacuum using the UP and the DOWN buttons.

Apply 50% full-scale vacuum. The character display will alternate between +MID and CAL. Adjust for a display indication equal to 50% of full-scale vacuum using the UP and the DOWN buttons.

Absolute Reference Gauges

Apply full vacuum to the gauge. The character display will alternate between ZERO and CAL. Press the UP and DOWN buttons to obtain a display indication of zero.

Apply full-scale pressure. The character display will alternate between +SPAN and CAL. Press the UP and DOWN buttons to obtain a display indication equal to full-scale pressure.

Apply 50% of full-scale pressure. The lower display will alternate between +MID and CAL. Press the UP and DOWN buttons to obtain an indication equal to 50% of full-scale pressure.

Compound and Bipolar Gauges

In addition to the steps described above for pressure gauges, apply full-scale vacuum. The character display will alternate between -SPAN and CAL. Adjust for a display indication of actual applied vacuum using the UP and the DOWN buttons.

For bipolar and -30.00inHg/+15.00psig compound range models only, apply 50% full-scale vacuum. The character display will alternate between -MID and CAL. Adjust for a display indication equal to 50% of full-scale vacuum using the UP and the DOWN buttons.

Save Calibration

Once the adjustments are complete, press and hold the front button until the display indicates ---- then release the button to store the calibration parameters in non-volatile memory and restart the gauge.

Verify the pressure indications at 0%, 25%, 50%, 75% and 100% of full scale.

Replace the rear cover taking care not to pinch the wires between the cover and the case.

User-Defined Pass Code Configuration

Remove the rear cover to access the buttons located near the lower right and left corners of the circuit board.

View Or Change User Configuration Pass Code

With the unit off, press and hold the UP button, then press the front button.

Release all buttons when the display indicates CFG.

View Or Change User Calibration Pass Code

With the unit off, press and hold the DOWN button, then press the front button.

Release all buttons when the display indicates CAL.

Enter Access Code 1220

Before the unit enters the view or change pass code mode, the display initially indicates ____ with the first underscore blinking, and with CFGPC or CALPC on the character display.

Note: The gauge will automatically revert to normal operation if no buttons are operated for approximately 15 seconds.

To cancel and return to normal operation, press and release the front button without entering any pass code characters.

1. Use the UP and DOWN buttons to set the left-most digit to 1.
2. Press and release the front button to move to the next position. The 1 will remain, and the second position will be blinking.
3. Use the UP and DOWN buttons to select 2.
4. Press and release the front button to index to the next position. 12 will remain, and the third position will be blinking.
5. Use the UP and DOWN buttons to select 2.
6. Press and release the front button to move to the next position. 1 2 2 will remain, and the fourth position will be blinking.
7. Use the UP and DOWN buttons to select 0.
8. Press and release the front button to proceed.

Note: If an incorrect access code was entered, the gauge will return to the start of the access code entry sequence.

Once the access code has been entered correctly, the display will indicate the existing user-defined pass code with CFGPC or CALPC on the character segments.

1. Operate the UP or DOWN button to select the first character of the new pass code.
2. When the correct first character is being displayed, press and release the front button to proceed to the next pass code character.
3. Repeat above until the entire pass code is complete.
4. To exit, press and hold the front button. Release the button when the display indicates ---- to restart the gauge.
5. Replace the rear cover taking care not to pinch the power wires between the cover and the case.