

REV	ECN	DESCRIPTION	DATE	DR	CK

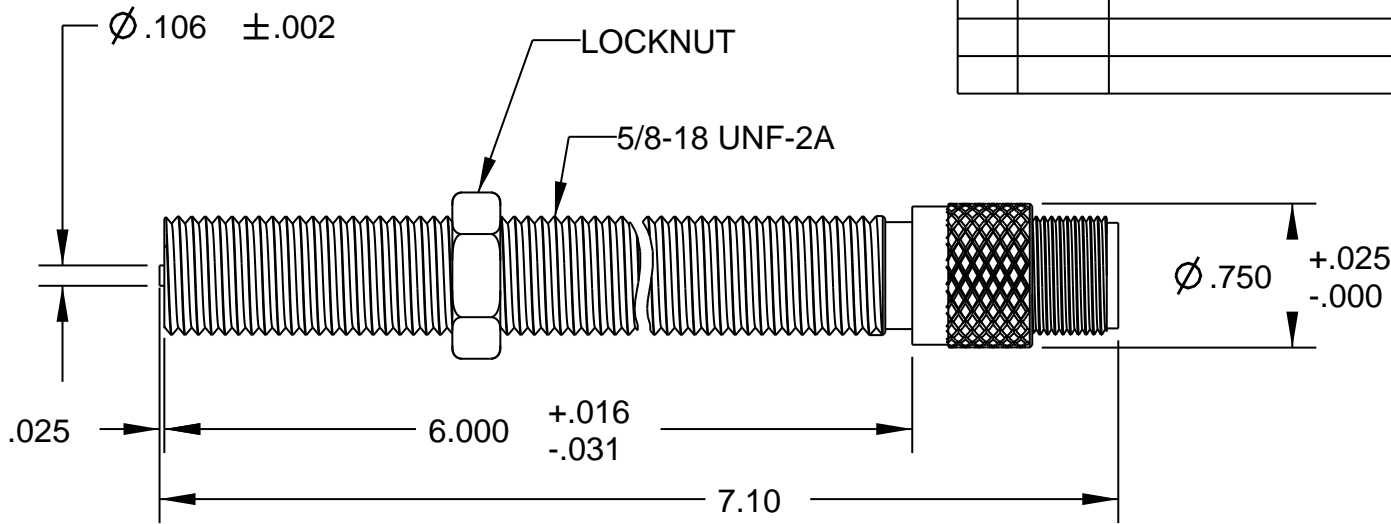

TEMPERATURE RANGE	OUTPUT VOLTAGE PEAK TO PEAK	DC RESISTANCE OHMS	INDUCTANCE AT 1KHZ	OUTPUT CONNECTOR	INSULATION RESISTANCE	NET WEIGHT
-65 ° F to +225 ° F	260-340 VOLTS (SEE NOTE 1)	2000-2300 AT 75 ° F	850 mH NOM	MATES WITH MS3106A-10SL-4S (SEE NOTE 2)	100 MEGOHMS MIN. AT 500 VDC, COIL TO HOUSING	4.8 OZ. AVG.

NOTES:

- 1- TESTED AT 1000 INCHES/SECOND WITH A 20 PITCH, 30 TOOTH GEAR, 0.005" CLEARANCE AND 100,000 OHM LOAD SHUNTED BY 250 MMF.
- 2- WITH APPROACH OF FERROUS METAL, PIN "B" IS POSITIVE WITH RESPECT TO PIN "A".

CONSTRUCTION:

HOUSING ----- 303 STAINLESS STEEL
 POLE PIECE --- 416 STAINLESS STEEL
 POTTING ----- EPOXY RESIN

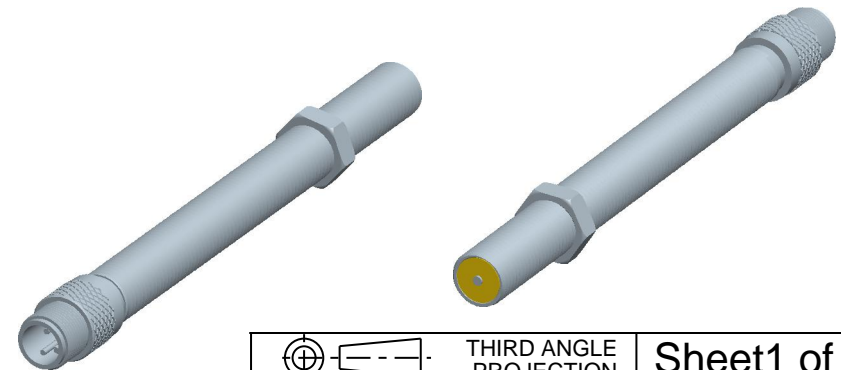

THIRD ANGLE PROJECTION		Sheet 1 of 1	
DYNALCO			
MODEL	M155-6	DRAWN	PF
PATH	MPROD\PICKUPS\M155-6	APPROVED	BR
TITLE MAGNETIC PICKUP, MODEL M155-6			
DATE	01/26/10	REV	-
		A 800-0155-6	

TOLERANCES	FRACT.	DEC.	ANGLES
	±1/64	.XXX±.005	±1/2°
		.XX±.01	
MATERIAL			
FINISH			

THIS DOCUMENT, ALL INFORMATION CONTAINED IN AND ALL INFORMATION RELATED TO THE PROPERTY OF DYNALCO CONTROLS, IS CONFIDENTIAL TO IT AND NO PART THEREOF NOR ANY SUBSTANTIAL INFORMATION MAY BE COPIED, DISSEMINATED OR USED IN ANY MANNER WHATSOEVER WITHOUT THE PRIOR WRITTEN CONSENT OF DYNALCO AND IS TO BE RETURNED TO DYNALCO UPON REQUEST.