

DIGITAL CALIBRATION PRESSURE GAGE

±0.05% FS Accuracy, 316 SS Wetted Parts

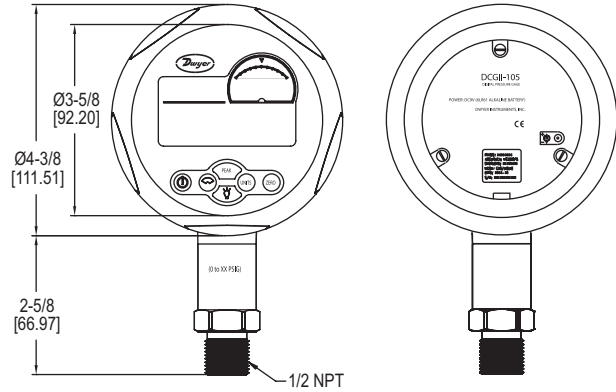

The **Series DCGII Digital Calibration Pressure Gauge** offers a complete pressure gage with calibration capabilities. With a precise 0.05% full scale accuracy and large 5 digit resolution, this gage can be used in critical industrial applications where precision is most important. This versatile gage only requires one 9V battery or power adapter and can operate up to 5,000 working hours. The Series DCGII 0.05% Digital Pressure Gauge can display percent of range, pressure swings or alarm set points. This pressure gage comes complete with eleven selectable pressure units, backlight and zeroing capability.

FEATURES/BENEFITS

- Highest accuracy provides exceptional measurement for calibration minimizing costly out of specification conditions
- Stainless steel housing resists ambient corrosion for longer service life in harsh environments
- Lightweight and slim, yet large easy to read battery-powered gage make them easy to carry and read
- Specified with high ambient temperature rating means more robust uses and longer service-life
- Indicator can display pressure swings, minimum and maximum peak detection with alarm set points provides a multipurpose tool where critical calibration is needed

APPLICATIONS

- Field gage calibration
- Permanent installation
- Burst disc testing
- Torque data logging
- Pressure regulator testing and hydrostatic leak testing

SPECIFICATIONS

- Service:** Compatible, non-combustible liquids and gases.
- Wetted Materials:** 316 SS.
- Other Materials:** Housing: Aluminum alloy; Display: Acrylic MR200; Buttons: Silicon gel; Back plate: 304 SS; Back seal: Oil-proof latex.
- Accuracy:** 0.05% FS; ±1 least significant digit.
- Temperature Accuracy:** ±1°C.
- Pressure Limits:** 120% FS.
- Temperature Limits:** 14 to 122°F (-10 to 50°C).
- Compensated Limits:** 32 to 122°F (0 to 50°C).
- Process Connection:** 1/2" male NPT.
- Display:** 5-digit LCD with blue backlight.
- Power Requirements:** 9 V alkaline battery, not included, or power adapter accessory.
- Battery Life:** Up to 10,000 hours (600 working hours @ default 3 times/s).
- Auto Shut-Off:** Backlight: On/off, 10 s, 20 s, 30 s.
- Weight:** 1.28 lb (0.58 kg).
- Agency Approvals:** CE.

MODEL CHART

Model	Range (psig)	kPa	mPa	kgf/cm ²	in H ₂ O	in Hg	mm Hg	psi	mbar	bar
DCGII-100	-14.7 to 0	-101.35	-0.1013	-1.0335	-406.90	-29.929	-760.21	-14.700	1013.5	-1.0135
DCGII-101	0 to 15	103.42	0.1034	1.0546	415.20	30.540	775.72	15.000	1034.2	1.0342
DCGII-102	0 to 30	206.84	0.2067	2.1092	830.40	61.080	1551.4	30.000	2068.4	2.0684
DCGII-103	0 to 60	413.69	0.4134	4.2184	1660.8	122.16	3102.9	60.000	4136.9	4.1369
DCGII-104	0 to 100	689.48	0.6890	7.0307	2768.0	203.60	5171.5	100.00	6894.8	6.8948
DCGII-105	0 to 200	1379.0	1.3780	14.061	5536.0	407.20	1034.3	200.00	1379.0	13.790
DCGII-106	0 to 300	2068.4	2.0670	21.092	8304.0	610.80	1551.4	300.00	2068.4	20.684
DCGII-107	0 to 500	3447.4	3.4450	35.153	1384.0	1018.0	2585.7	500.00	3447.4	34.474
DCGII-108	0 to 1000	6894.8	6.8900	70.307	2768.0	2036.0	5171.5	1000.00	6894.8	68.948
DCGII-109	0 to 2000	1379.0	13.780	140.61	5536.0	4072.0		2000.00		137.90

ACCESSORIES

Model	Description
A-644	9 V DC power adapter
BBV-0N	2-valve block manifold
PCHP-10	Pneumatic calibration pump

OPTIONS

Use order code:	Description
NISTCAL-PG2	NIST traceable pressure calibration certificate

See page 216 (Series PCHP)